



Utica Boiler - MAC-115 - Submittal



Engineer: _____

Project Name: _____

Project Location: _____

Contractor: _____

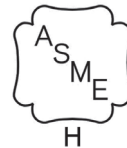

APPLICATION:

Modulating Gas fired Combi boiler for indoor installation. Approved for closet or alcove installations. For use with natural or liquefied petroleum (LP/Propane) fuel gases. Wall mounted. All boilers are factory assembled with controls and wiring and test fired to ensure dependable performance. Boiler shall be certified for Direct Vent applications only.

CERTIFICATION AND APPROVALS:

Stainless Steel heat exchanger is manufactured and tested in accordance with American Society of Mechanical Engineers (ASME) and certified by Canadian Standards Association (CSA), AHRI, NRCAN). Registered with National Board BPVI, and Massachusetts Board. Stainless steel heat exchanger is tested for maximum allowable working pressure of 50 psig in accordance with ASME boiler and pressure vessel code, section IV, rules for construction of heating boilers. A 30 psig safety relief valve is shipped standard.

BOILERS INCLUDE:

- Wall mount bracket, mounting hardware and actual size Wall Mount Template
- Boiler is equipped with internal stainless steel brazed plate heat exchanger for potable hot water and automatic 3 way diverting valve to allow Domestic Hot Water Priority operation.
- Boiler includes factory installed and wired 2 speed circulator pump.
- Factory provided primary / secondary **Labor Savor™** manifold.
- Digital Boiler Control:
 - ▶ Control is Self Commissioning, automatically recognizes fuel type (Natural or LP gas).
 - ▶ Control monitors flame signal and automatically adjusts the gas valve during operation for optimum combustion and maximum efficiency.
 - ▶ Control system is PCB integral controller with LCD digital/graphical display.
 - ▶ Control senses supply water temperature and adjusts the boiler firing rate to deliver the amount of heat needed.
 - ▶ Control can sense and display supply water temperature and indicate when boiler is in central heating or domestic water mode.
 - ▶ Control has selectable DHW preheat mode. Preheat mode will maintain brazed plate heat exchanger temperature to speed DHW delivery.



ECR international

Manufactured by:
ECR International Inc.
2201 Dwyer Avenue, Utica, NY 13501
Tel. 800 325 5479
www.ecrinternational.com
PN 615000358 REV. C [10/15/2021]



- ▶ Control can accept an optional proprietary Outdoor Air sensor and has field adjustable reset curves.
- ▶ Control displays Error Codes and Diagnostic information.
- ▶ Control can accept 0-10V input to manage heating set-point or heating power level
- Boiler Combustion System:
 - ▶ The Gas valve is a modulating valve capable of firing from:
 - 115,500 BTU input down to 16,600 BTU input in Combi mode (6.9:1 turn down).
 - 93,500 BTU input down to 16,600 BTU input in Heat mode (5.6:1 turn down).
 - ▶ Induced draft blower is variable speed controlled by the PCB.
 - ▶ Burner is constructed of Iron-Chromium stainless steel.
 - ▶ Ignition system shall incorporate a Direct Spark Igniter and a separate Flame Sensing rod.
- Heat Exchanger:
 - ▶ Boiler's primary heat exchanger is constructed of Iron-Chromium stainless steel.
 - ▶ DHW brazed plate is constructed of Stainless Steel.
- Electrical
 - ▶ 120 volts AC, 60 Hertz, 1-phase; less than 12 amps (15 amp circuit recommended).
 - ▶ Factory wired 3-foot appliance cord with male plug end.
 - ▶ Low voltage terminal strip for Thermostat, and Outdoor Air Sensor.
- Other:
 - ▶ Field supplied Anti-Scald valve is required for Domestic Hot Water Supply.
- Warranty
 - ▶ Factory Standard Warranty is 10 years on heat exchanger, one year on parts.
 - ▶ Warranty is extended to 10 years on heat exchanger, two years parts plus two years labor upon online warranty registration and completion of contractor registration.
- Optional Equipment
 - ▶ Outdoor Air Sensor Kit
 - ▶ Coaxial and Two-pipe venting components





					
Model Number	CH Input, MBH ⁽¹⁾		⁽¹⁾⁽²⁾ CH Heating Capacity, MBH	⁽¹⁾⁽³⁾ Net AHRI Rating Water, MBH	⁽²⁾ AFUE%
	Maximum	Minimum			
MAC-115	93.5	16.6	85.4	74	95.0
<p>(1) 1000 Btu/hr (British Thermal Units Per Hour) (2) Heating Capacity and AFUE (Annual Fuel Utilization Efficiency) are based on DOE (Department of Energy) test procedures. (3) Net AHRI Ratings based on piping and pickup allowance of 1.15. Contact Technical Support before selecting boiler for installations having unusual piping and pickup requirements, such as intermittent system operation, extensive piping systems, etc.</p>					

*Max CH Supply temp 176° F (80°C)

* Allowance for piping at the bottom of boiler not included.

Clearances ⁽¹⁾ Required distances measured from boiler. ⁽²⁾ Service, proper operation clearance recommendation. * Allowance for piping at bottom of boiler not included		Combustible Materials (Required) ⁽¹⁾		Service ⁽¹⁾⁽²⁾	
	Top	0" (0 mm)		9-13/16" (250 mm)	
	Left Side	1-3/4" (45 mm)		1-3/4" (45 mm)	
	Right Side	1-3/4" (45 mm)		1-3/4" (45 mm)	
	Front	0" (0 mm)		17-3/4" (450 mm)	
	Back	0" (0 mm)		0" (0 cm)	
	Bottom	0" (0 mm)		*9-13/16" (250 mm)	
	Combustion Air/ Venting Piping	0" (0 mm)		6" (160 mm)	
Dimension/Weights	Model	"Width"	"Height"	"Depth"	"Weight"
	MAC-115	17-3/4 "	30"	13-9/16"	103
		450 mm	763 mm	345mm	46.72 kg



Manufactured by:
 ECR International Inc.
 2201 Dwyer Avenue, Utica, NY 13501
 Tel. 800 325 5479
www.ecrinternational.com
 PN 615000358 REV. C [10/15/2021]



MAC 115			
Central Heating	MAX		MIN
Altitude (ft)	0-2000	2000-4500	-
Heat Input (BTUH)	93,550	88,873	16,650
Heat Output (BTUH)	85,400	81,130	15,350
CO ₂ Setting Natural Gas (%)	9.0	9.0	8.6
Gas Rate Natural Gas (ft ³ /h)	92.08	87.14	16.58
CO ₂ Setting LP Gas (%)	10.0	10.0	9.8
Gas Rate LP Gas (ft ³ /h)	36.34	34.57	6.35
CH Water Temp (°F)	176		
Supply Connection (inches)	3/4		
Return Connection (inches)	3/4		
Domestic Hot Water	MAX		MIN
Altitude (ft)	0-2000	2000-4500	-
Heat Input (BTUH)	115,500	109,725	16,650
Heat Output (BTUH)	105,500	100,225	15,350
CO ₂ Setting Natural Gas (%)	9.0	8.7	8.7
Gas Rate Natural Gas (ft ³ /h)	113.60	107.96	16.58
CO ₂ Setting LP Gas (%)	10.0	10.0	10.0
Gas Rate LP Gas (ft ³ /h)	44.81	42.63	6.35
Min Domestic Flow Rate (gpm)	0.55		
Max. Domestic Flow Rate at a 70°F rise (gpm)	2.50		
Domestic Hot Water (°F)	140		
Domestic Cold Water Inlet (inches)	1/2		
Domestic Hot Water Outlet (inches)	1/2		
Central Heating System			
Max. System Pressure (psi/bar)	30 / 2.11		
Min. System Pressure (psi/bar)	7.25 / 0.5		
Max. System Temperature (°F)	176		
Pressure Relief Setting (psi/bar)	30 / 2.11		
Recommended System Pressure Cold (psi/bar)	21.7 / 1.5		
Expansion Tank size (pre-charge pressure)	1.5 gal (US) at 11.6 psi		



Manufactured by:
 ECR International Inc.
 2201 Dwyer Avenue, Utica, NY 13501
 Tel. 800 325 5479
www.ecrinternational.com
 PN 615000358 REV. C [10/15/2021]



Domestic Hot Water

Max. Inlet Water Pressure	116 psi / 8 bar
Min. Inlet Water Pressure	2.9 psi / 0.2 bar
Min. DHW Flow Rate	0.55 gpm / 2.50 l/min
Max. DHW Temperature	140°F / 60°C
DHW Water Content	1.05gal / 0.23 L

Electrical

Supply Voltage	120v 60Hz
Power Consumption (Watts)	125
Internal Fuse (Amps)	3.15

General

Gas Connection (inches)	3/4
Lift Weight (lbs)	102.51



Manufactured by:
ECR International Inc.
2201 Dwyer Avenue, Utica, NY 13501
Tel. 800 325 5479
www.ecrinternational.com
PN 615000358 REV. C [10/15/2021]



Top View

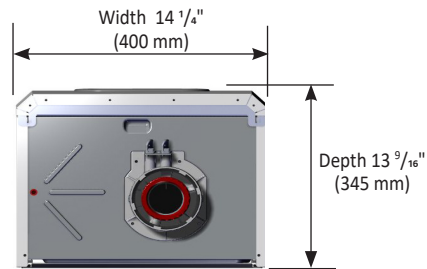

Front View

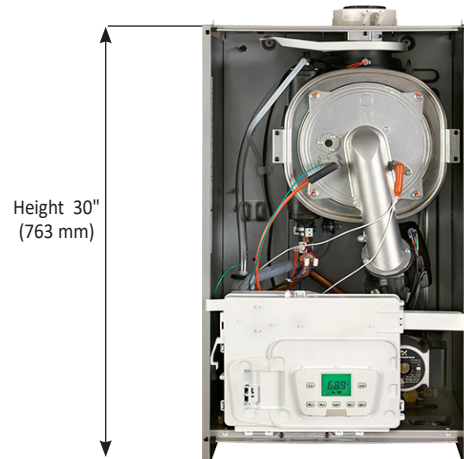

Manufactured by:
ECR International Inc.
2201 Dwyer Avenue, Utica, NY 13501
Tel. 800 325 5479
www.ecrinternational.com
PN 615000358 REV. C [10/15/2021]

VENTING OPTIONS

Please refer to the installation manual section 5. VENT SYSTEM for more information.

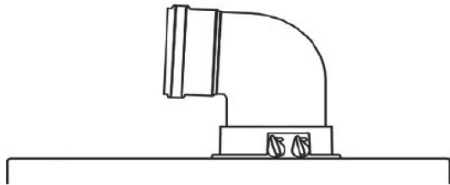
Concentric Venting - Ø 100mm/60mm

A B	L _{max} = 32.80 / 10.00 m - Ø 60/100 mm
C D	L _{max} = 29.52 / 9.00 m - Ø 60/100 mm
E F	L _{max} = 32.80 / 10.00 m - Ø 60/100 mm
G	L _{max} = 26.24 / 8.00 m - Ø 60/100 mm
H	L _{max} = 29.52 / 9.00 m - Ø 60/100 mm

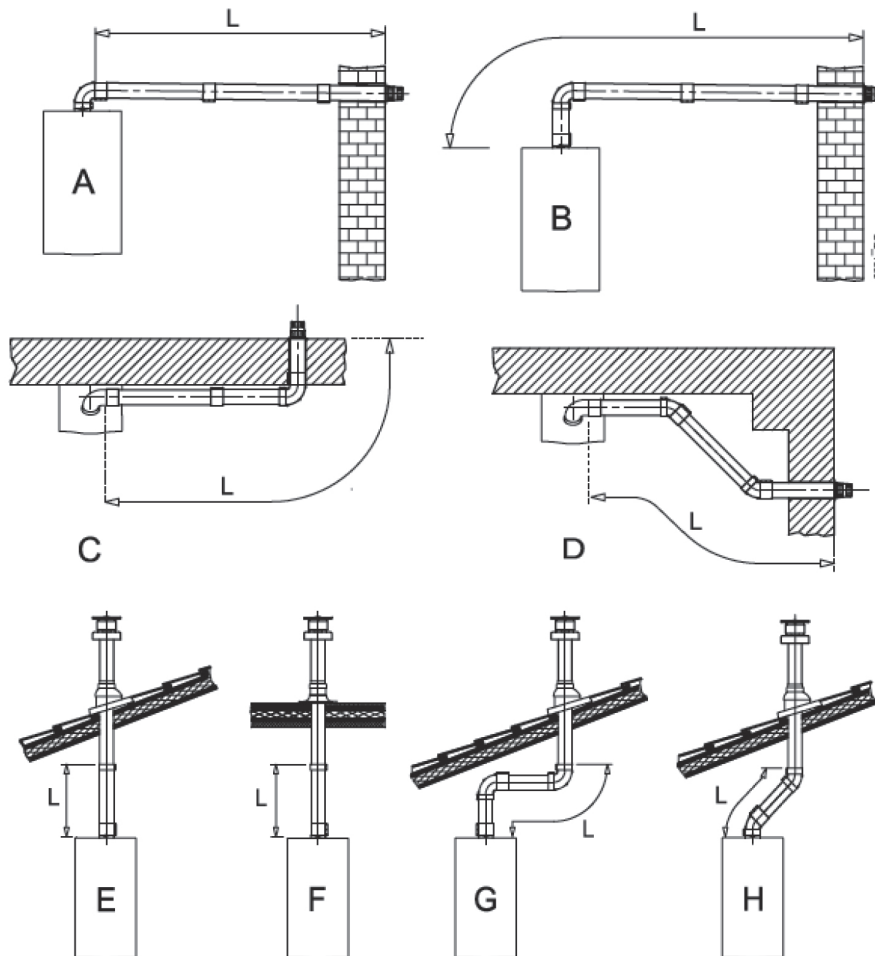



Dual Flue Venting - BAXI Polypro Venting \varnothing 80mm or 3" CPVC S636

I	L max = 49.20 / 15.00 m
L	L max = 49.20 / 15.00 m
M	L max = 45.92 / 14.00 m

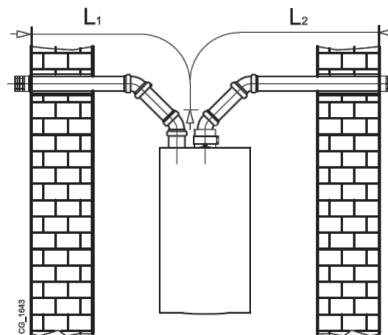
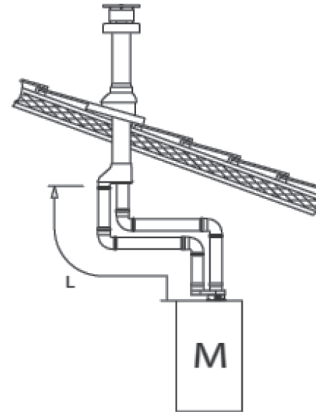
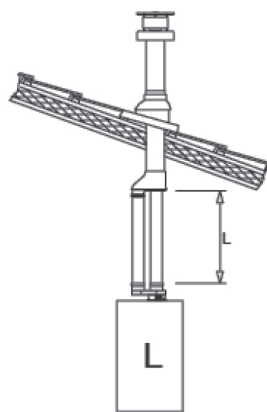
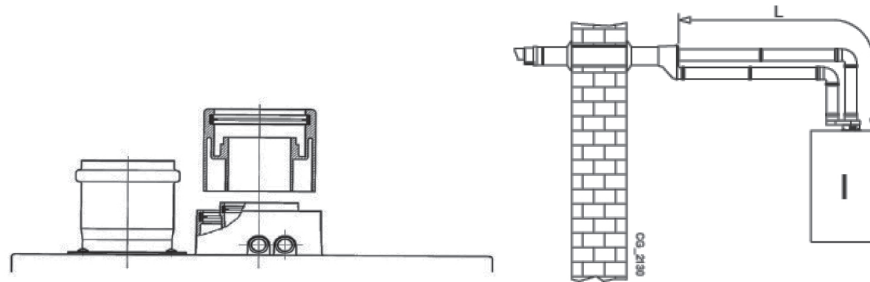

L1 MAX = 49.2 ft / 15.00 m
 L2 MAX = 147.6 ft./45.00 m
 L1 + L2 = 196.8 ft. / 60.00 m



2201 Dwyer Avenue, Utica, NY 13501
 Tel. 800 325 5479
www.ecrinternational.com

All specifications subject to change without notice.
 ©2021 ECR International, Inc.