

Aprilaire®

Effective Date: April 1, 2021
Revised Date: May 10, 2021

Dehumidifiers Wholesale Parts and Price List

Model E080/E080H/E100/E100H/E100C/E100V Dehumidifiers

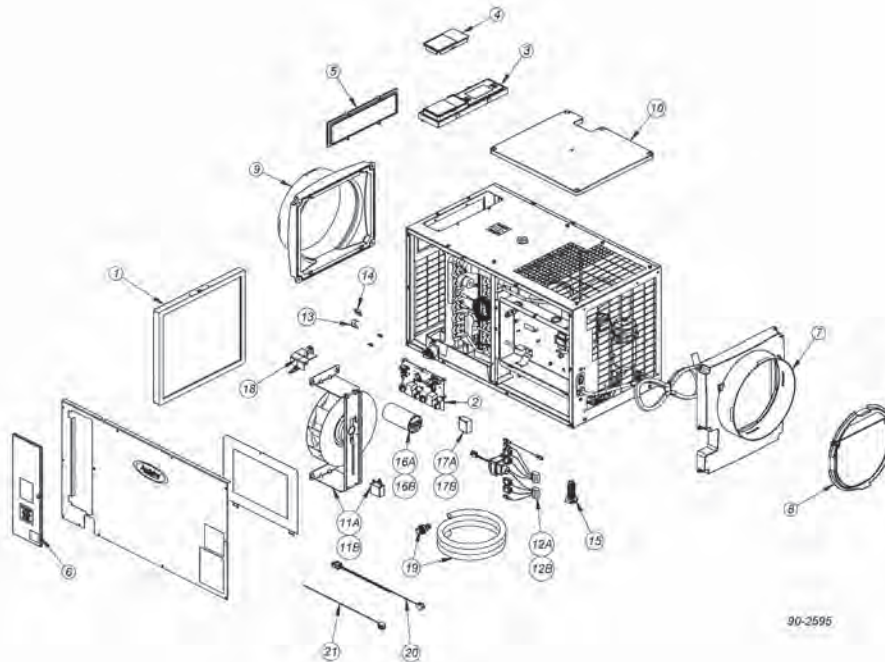

NO.	PART DESCRIPTION	QTY/CTN	PART NO.
1	EZK Filter, 13.5" x 11.875" x 0.875	1	5881
2	Internal Control Board	1	5444
3	User Interface Assembly	1	5445
4	Wiring Access Door	1	5446
5	UI Control Hole Cover	1	5447
6	Filter Access Door (E080 & E100)	1	5882
7	Outlet Duct Panel	1	5449
8	10" Backflow Damper	1	5450
9	Inlet Duct Panel	1	5451
10	Outlet Cover	1	5452
11A	Fan with Run Capacitor, 6MFD, 250VAC, 80 Pint	1	5883
11B	Fan with Run Capacitor, 12MFD, 450VAC, 100 Pint	1	5886
12A	Transformer and Wire Harness	1	5884
12B	Transformer and Wire Harness for E100V	1	5888
13	Low Temperature Sensor	1	5455
14	High Temperature Sensor	1	5456
15	Leveling Foot	1	5457
16A	Compressor Run Capacitor, 80pt, 45MFD, 370VAC	1	5458
16B	Compressor Run Capacitor, 100pt, 50MFD, 370VAC	1	5594
17A	Fan Run Capacitor, 6MFD, 250VAC, 80 Pint	1	5582
17B	Fan Run Capacitor, 12MFD, 450VAC, 100 Pint	1	5468
18	Drain Insert	1	5885
19	Drain Tube + Fittings**	1	See Page 4 for Details
20	Internal 24V Wire Harness for E100V	1	5914
21	External 24V Wire Harness for E100V	1	5887
OTHER PARTS (Not Shown)			
	Low Profile Condensate Pump with 20' of 3/8" Drain Tube	1	4856
	Basement Kit (2-10" N/O Dampers, 2-10" N/C Dampers & 1 Transformer)	1	5442
	Digital Dehumidifier Control (for All Current Dehumidifiers)	1	76
	Living Space Duct Kit (25' of Insulated Flex Duct with 2 Quick Install Grilles and 2 Reducers)	1	5546
	Dehumidifier Hanging Kit	1	5660
	Hanging Kit for E-Series Dehumidifiers	1	5822

**Drain Tube Only Included with E100C

Model 1830/1830W/1850/1850F/1850W/1852 Dehumidifiers

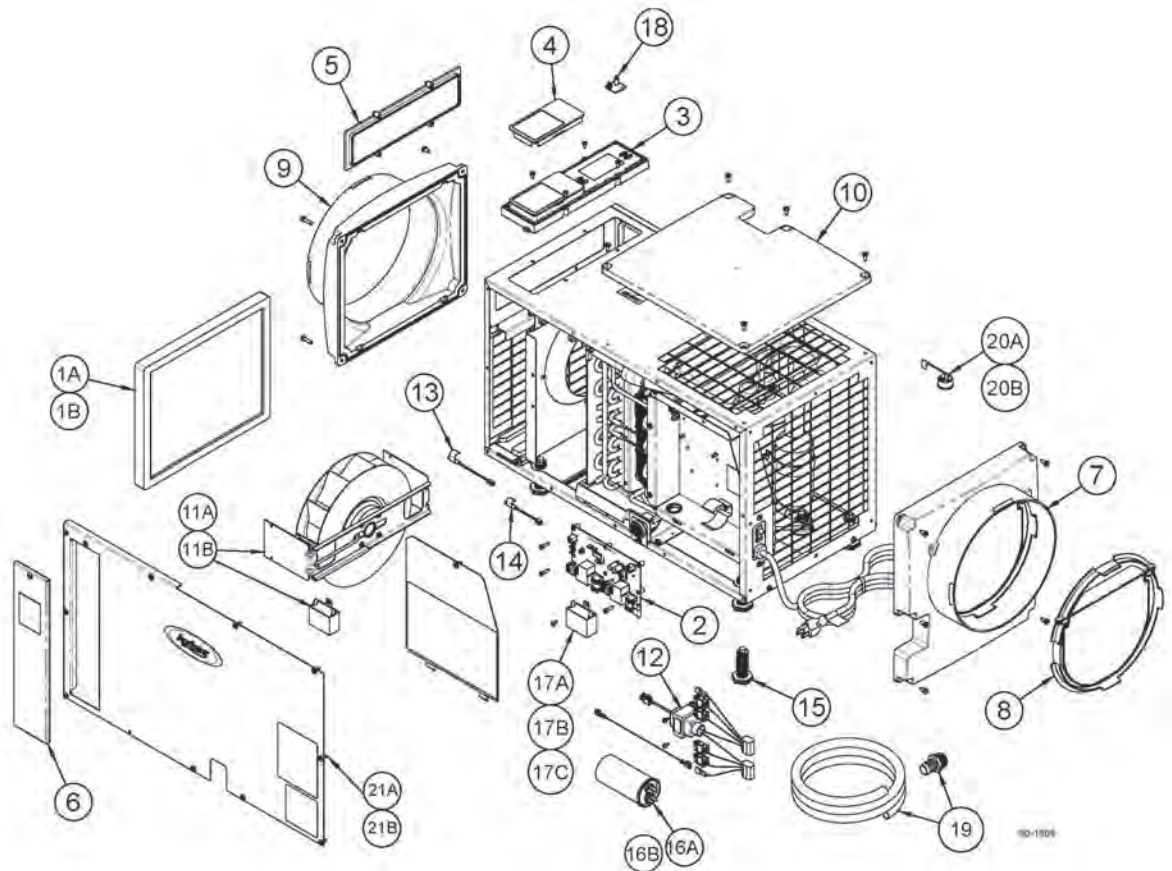

NO.	PART DESCRIPTION	QTY/CTN	PART NO.
1A	Filter, 10" x 12" x 1" EZK (1830, 1850 & 1852)*	1	5443
1B	Filter, 12" x 12" x 1" EZK (1850F Only)	1	5499
2	Internal Control Board	1	5444
3	User Interface Assembly	1	5445
4	Wiring Access Door	1	5446
5	UI Control Hole Cover	1	5447
6	Filter Access Door (1830 & 1850)	1	5448
7	Outlet Duct Panel	1	5449
8	10" Backflow Damper	1	5450
9	Inlet Duct Panel	1	5451
10	Outlet Cover	1	5452
11A	70 Pint Dehumidifier Fan	1	5453
11B	95 Pint Dehumidifier Fan	1	5467
12	Transformer and Wire Harness	1	5454
13	Low Temperature Sensor	1	5455
14	High Temperature Sensor	1	5456
15	Leveling Foot*	1	5457
16A	Compressor Run Capacitor, 70pt, 45MFD, 370VAC	1	5458
16B	Compressor Run Capacitor, 95pt, 50MFD, 370VAC	1	5594
17A	Fan Run Capacitor, 8MFD, 450VAC, Used on Model 1830 with Serial Number Before 112015A09596	1	5459
17B	Fan Run Capacitor, 6MFD, 250VAC, Used on Model 1830(W) with Serial Number 112015A09596 or Later	1	5582
17C	Fan Run Capacitor, 12MFD, 250VAC, Used on Models 1850(F)(W) & 1852	1	5468
18	RH Sensor used on models with detachable Temp/RH daughter board	1	5460
19	Drain Tube + Fittings**	1	See Page 4 for Details
20A	Compressor Overload Switch, 70pt	1	5547
20B	Compressor Overload Switch, 95pt	1	5548
21A	Right Service Panel for 1830	1	5918
21B	Right Service Panel for 1850	1	5920
OTHER PARTS (Not Shown)			
	Low Profile Condensate Pump with 20' of 3/8" Drain Tube	1	4856
	Basement Kit (2-10" N/O Dampers, 2-10" N/C Dampers & 1 Transformer)	1	5442
	Digital Dehumidifier Control (for All Current Dehumidifiers)	1	76
	Living Space Duct Kit (25' of Insulated Flex Duct with 2 Quick Install Grilles and 2 Reducers)	1	5546
	Dehumidifier Hanging Kit	1	5660
	Hanging Kit for 1800 Series Dehumidifiers	1	5822
	Left Service Panel for 1830	1	5917
	Left Service Panel for 1850	1	5919

* Not Compatible with 1850F

**Drain Tube Only Included with 1850F/1852

Model 1870/1870F/1870W/1872/E130/E130H/E130C Dehumidifiers

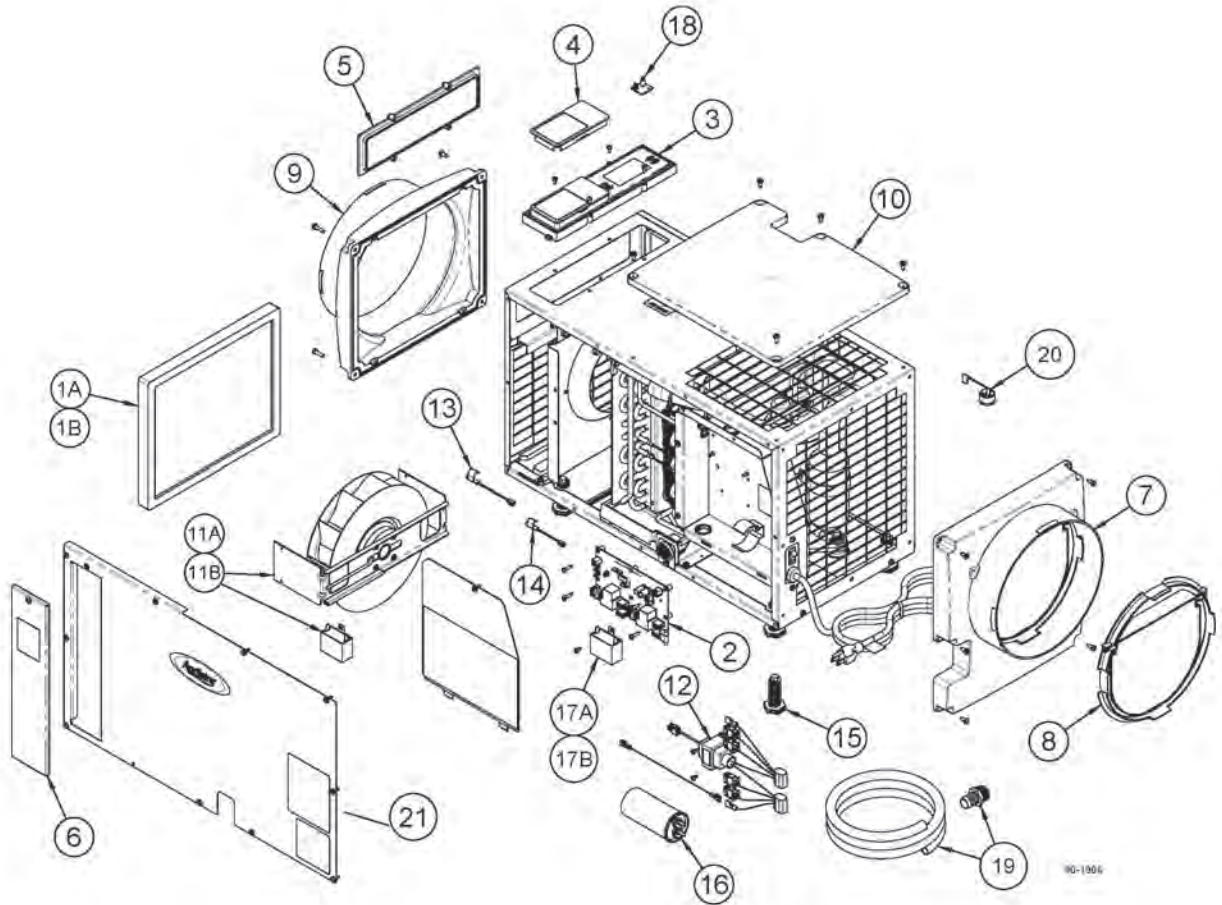

NO.	PART DESCRIPTION	QTY/CTN	PART NO.
1A	Filter, 14" x 19" x 1" EZK (1870 & 1872) ¹	1	5569
1B	Filter, 16" x 19" x 1" EZK (1870F)	1	5570
2	Internal Control Board	1	5444
3	User Interface Assembly	1	5445
4	Wiring Access Door	1	5446
5	UI Control Hole Cover	1	5447
6	Filter Access Door	1	5571
7	Outlet Duct Panel	1	5449
8	Backflow Damper, 10"	1	5450
9	Inlet Duct Panel	1	5451
10	Outlet Cover	1	5452
11A	Fan, 130pt with 10MFD Capacitor (1870)	1	5572
11B	Capacitor, 10MFD, 250V	1	5573
12	Transformer and Wire Harness	1	5454
13	Low Temperature Sensor	1	5455
14	High Temperature Sensor	1	5456
15	Leveling Foot ¹	1	5457
16	Capacitor, 70MFD, 370VAC, Compressor Run Capacitor	1	5941
17A	Capacitor, 10MFD, 250VAC, Fan Run Capacitor	1	5573
17B	Capacitor, 8MFD, 450VAC for the Model 1870F, Fan Run Capacitor	1	5459
18	RH Sensor used on models with detachable Temp/RH daughter board	1	5460
19	Drain Tube + Fitting ²	1	See Page 4 for Details
20	Compressor Overload Switch	1	5574
21	Right Service Panel	1	5922
OTHER PARTS (Not Shown)			
	Low Profile Condensate Pump with 20' of 3/8" Drain Tube	1	4856
	Hanging Kit for 1870 Series Dehumidifiers	1	5691
	Hanging Kit for 1800 Series Dehumidifiers	1	5822
	Left Service Panel	1	5921

¹Not Compatible with 1870F

²Drain tube only included with 1870F & 1872

Drain Fittings for 1800-Series and E-Series Dehumidifiers

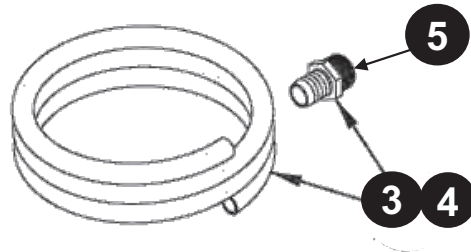

NO.	PART DESCRIPTION	QTY/CTN	PART NO.
1	Original Drain Fittings, ½ MNPT x ½ Barb & ¾ M Slip x ½ FNPT Reducer	1	5461
2	2nd Generation Drain Fitting, Custom Outlet Barb ¾ M Slip x ½ Barb	1	5585
3	New Threaded Fitting, ¾" MNPT x ¾" Barb, with 5ft of ¾" Drain Tube	1	5665
4	New Threaded Fitting, ¾" MNPT x ¾" Barb, with 10ft of ¾" Drain Tube ¹	1	5692
5	New Threaded Fitting, ¾" MNPT x ¾" Barb (Fitting Only) ¹	1	5693

¹E-Series Dehumidifiers use #5693 Threaded Fitting or #5692 Threaded Fitting and Drain Tube

Model 1730A with R410A Dehumidifier

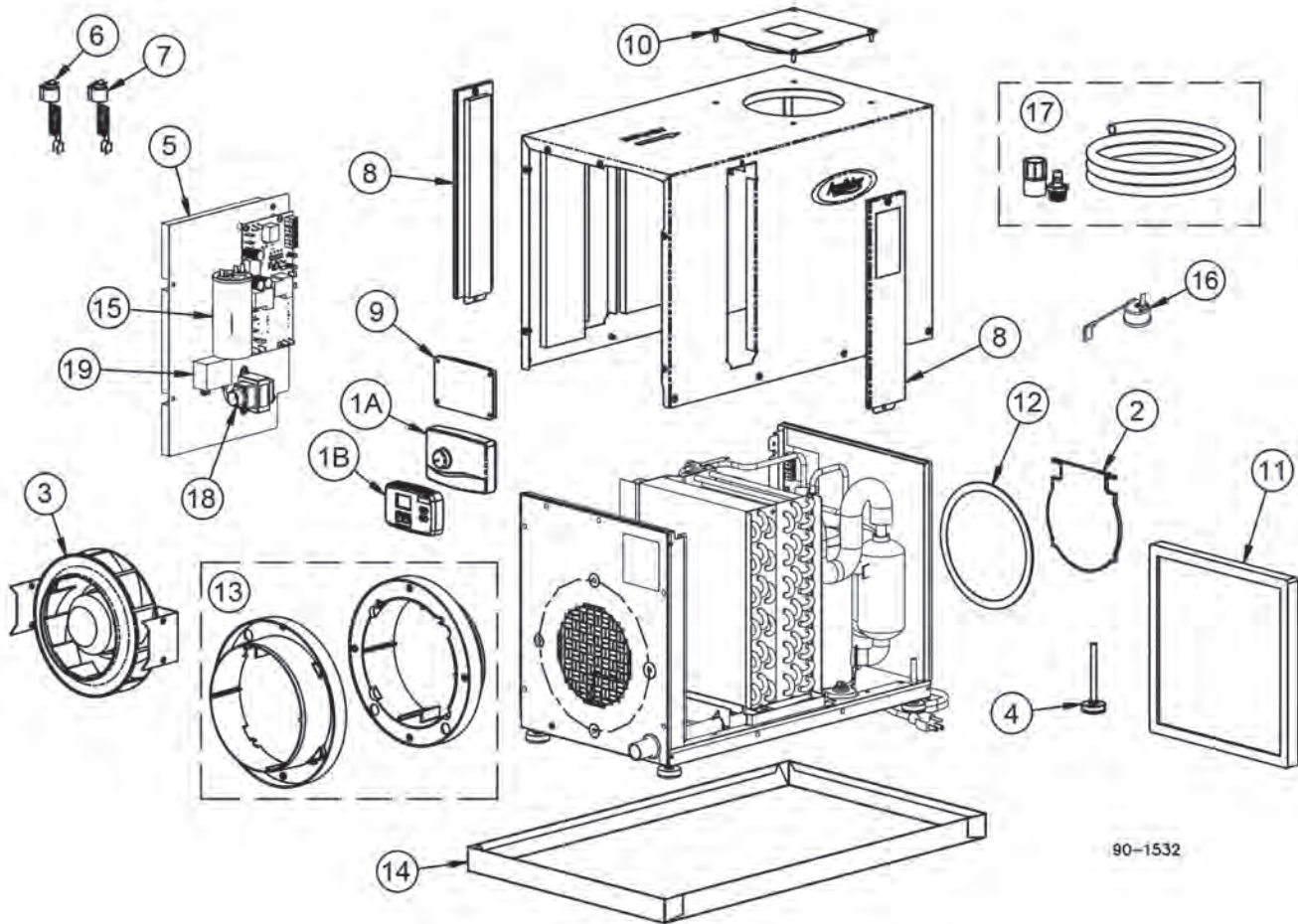

90-1532

NO.	PART DESCRIPTION	QTY/CTN	PART NO.
1A	Dehumidistat Control Assembly	1	4917
1B	Digital Dehumidifier Control	1	76
2	Backflow Damper	1	4918
3	Impeller with Bracket (Blower Assembly) ³	1	5332
4	Leveling Foot	1	4920
5	Control PCB Assembly ⁴	1	5329
6	High Temperature Cutout Switch	1	4924
7	Low Temperature Cutout Switch	1	4925
8	Filter Access Door Assembly	1	4926
9	Dehumidistat Hole Cover	1	4927
10	Outlet Cover Plate	1	4928
11	Air Filter	1	4904
12	Inlet/Outlet Screen	1	4930
13	Duct Collars	2	4751
14	Auxiliary drain pan	1	4911
15	Capacitor, 55MFD	1	4922
16	Compressor Overload Switch	1	5324
17	Condensate Drain Hose Assembly	1	4863
18	10VA Transformer with Wire Harness	1	5398
19	Capacitor, 10MFD for Impeller	1	5399
OTHER PARTS - NOT INCLUDED			
	Low Profile Condensate Pump with 20' of 3/8" Drain Tube	1	4856
	Living Space Duct Kit (25' of 8" Insulated Flex Duct with 2 Quick Install Grilles)	1	4857
	Living Space Duct Kit (25' of Insulated Flex Duct with 2 Quick Install Grilles and 2 Reducers)	1	5546

³Part No. 4919 replaced by 5332

⁴Part No. 4923 replaced by 5329

Model 1710A/1750A/1770A Dehumidifiers

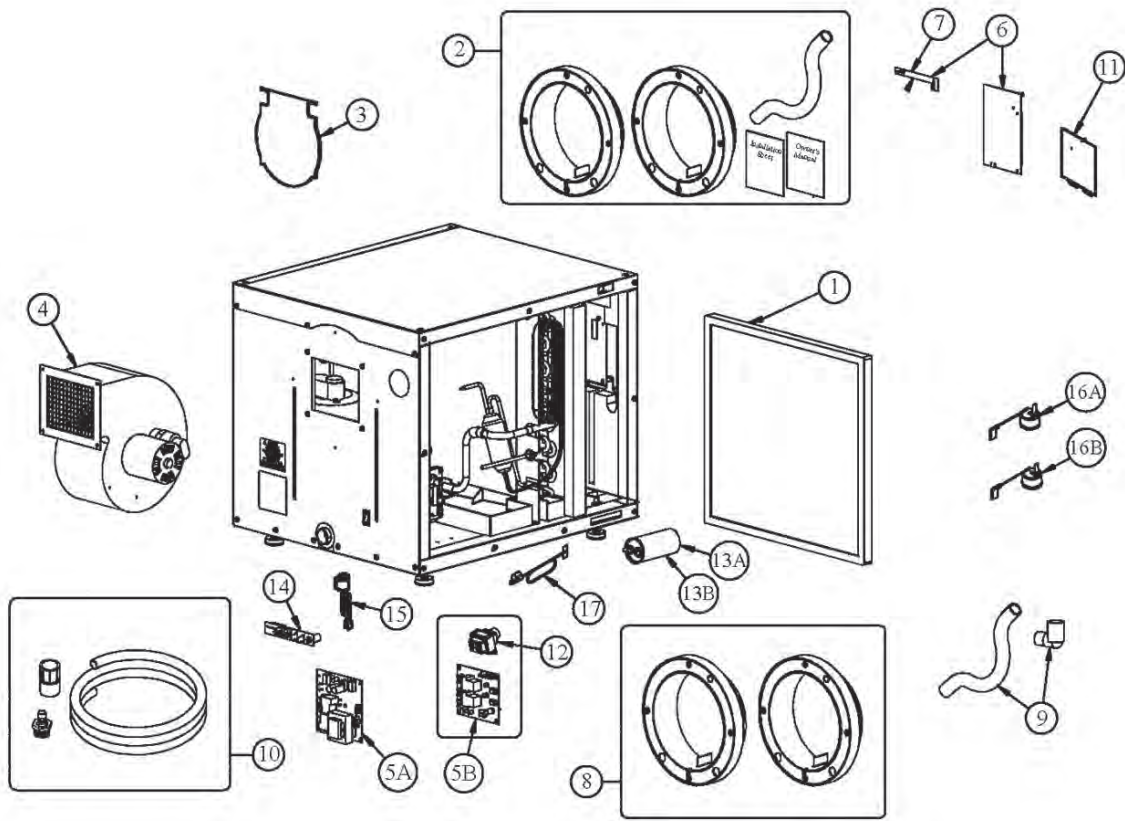

Model 1710A/1750A/1770A Dehumidifiers

NO.	PART DESCRIPTION	QTY/CTN	Model 1710A/1750A/1770A	Model 1700/1710/1720/1750/1770
			PART NO.	PART NO.
1	Filter	1	4510	4510
2	Drain Trap/Collars/Manual	1	4843	4843
3	Backflow Damper ⁵	1	4918	4918
4	Blower/Motor Assembly, 1710A/1750A and 1700/1710/1750	1	4515	4515
	Blower/Motor Assembly, 1770A and 1720/1770	1	4646	4646
5A	Power Supply Board		See Table 1 Below	
5B	Power Supply Board (New Style Without Integrated Transformer)			N/A
6	Control Board Kit ⁶	1	5353	5353
7	Sensor Board	1	4752	4752
8	Duct Collars	2	4751	4751
9	Drain Trap and PVC Elbow	1	4842	4842
10	Condensate Drain Hose Assembly (Included with Model 1710A Only)	1	4863	N/A
11	LED Control Door	1	4864	4864
12	10 VA Transformer	1	5262	5262
13A	Capacitor, 60MFD (Model 1770A Only)	1	5255	N/A
13B	Capacitor, 55MFD	1	4922	N/A
14	Daughter Board	1	5264	N/A
15	High Temperature Cutout Switch	1	4924	N/A
16A	Compressor Overload Switch, 1710A/1750A	1	5324	N/A
16B	Compressor Overload Switch, 1770A	1	5325	N/A
17	Frost Sensor	1	5422	N/A
OTHER PARTS				
	External Control ⁷	1	76	70
	Convertible Installation Kit (2-N/O 8" Damper, 2-N/C 8" Damper and Transformer)	1	4522	4522
	Distributor and Nozzle, 1710A/1750A	1	4903	N/A
	Low Profile Condensate Pump with 20' of 3/8" Drain Tube	1	4856	4856
	Living Space Duct Kit (25' Of 8" Insulated Flex Duct With 2 Quick Install Grilles)	1	4857	4857
	Living Space Duct Kit (25' of Insulated Flex Duct With 2 Quick Install Grilles and 2 Reducers)	1	5546	5546

⁵ The Backflow Damper (Part No. 4918) is Compatible with All Models 1730A, 1770A, but Only with Model 1750A with Serial Numbers Greater than 2610AA147015.

⁶ If Control Board being Replaced is Currently Used with a Model 70 Control, the Control Must be Replaced with a Model 76 Control.

⁷ Only use a Model 70 Control to Replace an Existing Model 70 Control with Units Produced Before Serial Number 4610AAXXXXXX.

NO.	PART DESCRIPTION	Compatible With	QTY/CTN	PART NO.
5A	Power Supply Board	Control Board without DH Terminal	1	4517
5B	Power Supply Board (New Style without Integrated Transformer)	Control Board with DH Terminal ⁸	1	5260

⁸ DH Terminal Implemented on All Units with Serial Number 4610AAXXXXXX or Later.

Identifying Type of Control by Terminal Block

MODEL 70



MODEL 75

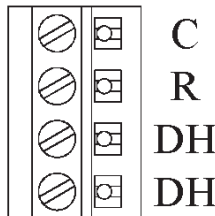

MODEL 76

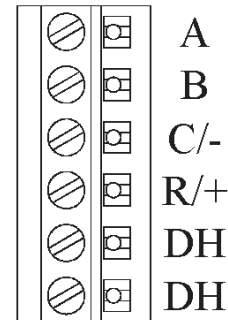

90-1976



PO Box 1467 • Madison, WI 53701-1467 • Phone: 800.334.6011 • Fax: 608.257.4357 • www.AprilairePartners.com

Printed in the USA