



FLEXIBILITY



Products you need
from people who care

**S20W HIGH PERFORMANCE
WALL-MOUNTED INDIRECT**

S20W HIGH-PERFORMANCE WALL-MOUNTED INDIRECT



Ultra high-performance 20 gallon indirect, with first hour recovery rate exceeding all competition



Pound for pound our most powerful tank, with higher performance than a 65 gallon indirect.



High quality Stainless Steel Tank & coil use type 444 **completely pickled and passivated and all fittings are type 316**



CFC-free 2" ultra high density EPS insulation, which increases efficiency by reducing standby losses



Full metal casing that matches all NTI boilers



Top hand hole for cleaning and inspection



All units provided with thermostatic mixing valve



Recirculation connection for optimal delivery



Optional floor stand (part #86998)



Limited lifetime warranty

NTI MOD CON INPUT (BTU)	1ST HR RATING (US GPH)		CONTINUOUS RATING (US GPH)	
	140° F	115° F	140° F	115° F
85,000	119	158	102	141
110,000	149	200	132	182
150,000	197	266	180	149
199,000	229	348	212	330

Performance values are based on 50° F inlet water temperature

Note: based on 179° F max delivery water temperature

Max performance 200 F boiler water at 15 gpm	323	500	306	483
---	-----	-----	-----	-----

DEPENDABLE BY DESIGN



Wall Mount

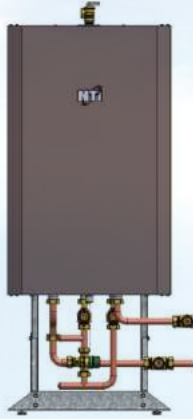

Floor Mount
with optional Floor Stand

At NTI, we manufacture all our products to the highest industry standards. Our in-factory Quality Control tests are the most rigorous in the industry.

Our limited lifetime warranty provides you with the assurance of years of worry-free operation and our Technical Support is second-to-none.

MAXIMUM CAPACITY

Our 444 stainless-steel coil provides for large heat recovery rates, and the opportunity to run lower boiler temperatures for increase efficiency. Our coil capacity is unmatched in the industry, and even outperforms typical 50 and 65 gallon indirects.

1st HR RATING (US GPH)	S20W	industry standard 40 gallon tank	industry standard 60 gallon tank
• 140 F	290	237	298
• 115 F	445	322	405
CONTINUOUS RATING (US GPH)			
• 140 F	273	203	249
• 115 F	428	288	356

200° F Boiler Water at 10gpm



Completely passivated inside and outside to remove all surface contaminations, and restore the chromium oxide layer of the stainless steel surface.

Included with each IWH:

- Low Lead Thermostatic mixing valve (ASSE 1017, ASSE 1070, cUPC and CSA125.3 approved)
- 10k NTC Tank Sensor with embedded UL353 limit switch
- 150 psi Temperature and Pressure Relief Valve
- Stainless steel well for insertion of Tank Sensor

DIMENSIONS

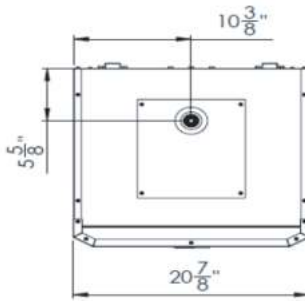

- 21 US gallon Capacity
- Max 150 PSIG.
- 3/4" NPT T&P relief valve.

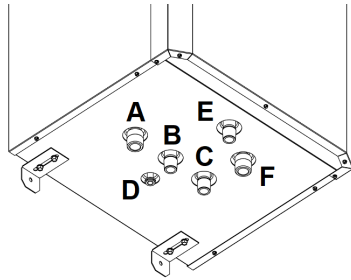

- A = From Boiler Supply*
- B = Cold Water Inlet/Drain**
- C = Hot Water Outlet**
- D = Aquastat (tube)
- E = DHW Recirc**
- F = To Boiler Return*

* 1" NPT-M
 ** 3/4" NPT-M

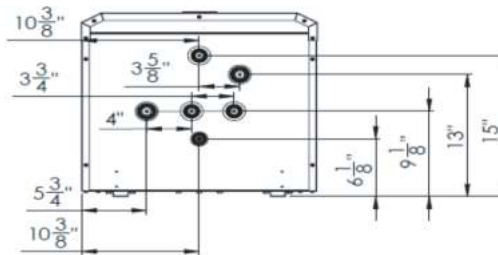
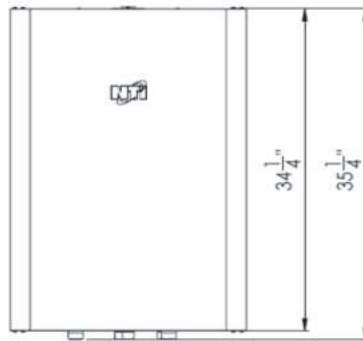

NTI BOILERS INC.

30 Stonegate Drive, Saint John
 New Brunswick E2H 0A4 Canada

Tel: 506-657-6000

Toll-free: 800-688-2575

Fax: 506-432-1135

www.ntiboilers.com