

# USER'S INFORMATION MANUAL

## HYDRONIC AIR HANDLER



Recognize this symbol as an indication of Important Safety Information!

### SAFETY

#### ▲ WARNING

**PROPOSITION 65: THIS HYDRONIC AIR HANDLER CONTAINS FIBERGLASS INSULATION. RESPIRABLE PARTICLES OF FIBERGLASS ARE KNOWN TO THE STATE OF CALIFORNIA TO CAUSE CANCER.**

**IMPORTANT:** The hydronic air handler can **only** be used when properly matched with a tankless water heater from the Manufacturer as specified by the Manufacturer.

**IMPORTANT: READ THESE INSTRUCTIONS THOROUGHLY BEFORE ATTEMPTING TO OPERATE THIS HYDRONIC AIR HANDLER.**

This hydronic air handler has been designed to give you many years of efficient, dependable home comfort.

With regular maintenance, this hydronic air handler will operate satisfactorily year after year. Please read this manual to familiarize yourself with operation, routine maintenance schedule, and safety procedures.

Do not use this hydronic air handler if any part has been under water. Immediately call a qualified installer or service agency to inspect the hydronic air handler and to replace any part of the control system which has been under water.

### GENERAL INFORMATION

#### ▲ WARNING

DUCT LEAKS CAN CREATE AN UNBALANCED SYSTEM AND DRAW POLLUTANTS SUCH AS DIRT, DUST, FUMES AND ODORS INTO THE HOME CAUSING PROPERTY DAMAGE. FUMES AND ODORS FROM TOXIC, VOLATILE OR FLAMMABLE CHEMICALS, AS WELL AS AUTOMOBILE EXHAUST AND CARBON MONOXIDE (CO), CAN BE DRAWN INTO THE LIVING SPACE THROUGH LEAKING DUCTS AND UNBALANCED DUCT SYSTEMS CAUSING PERSONAL INJURY OR DEATH (SEE FIGURE 1).

- IF AIR-MOVING EQUIPMENT OR DUCTWORK IS LOCATED IN GARAGES OR OFF-GARAGE STORAGE AREAS, ALL JOINTS, SEAMS, AND OPENINGS IN THE EQUIPMENT AND DUCT MUST BE SEALED TO LIMIT THE TOXIC FUMES AND ODORS, INCLUDING CARBON MONOXIDE, FROM MIGRATING INTO THE LIVING SPACE.
- IF AIR-MOVING EQUIPMENT OR DUCTWORK IS LOCATED IN SPACES CONTAINING FUEL BURNING APPLIANCES, SUCH AS WATER HEATERS OR BOILERS, ALL JOINTS, SEAMS, AND OPENINGS IN THE EQUIPMENT AND DUCT MUST ALSO BE SEALED TO PREVENT DEPRESSURIZATION OF THE SPACE AND POSSIBLE

MIGRATION OF COMBUSTION BYPRODUCTS, INCLUDING CARBON MONOXIDE, INTO THE LIVING SPACE.

#### ▲ NOTICE

IMPROPER INSTALLATION, OR INSTALLATION NOT MADE IN ACCORDANCE WITH THE UNDERWRITERS LABORATORIES (UL) CERTIFICATION OR THESE INSTRUCTIONS, CAN RESULT IN UNSATISFACTORY OPERATION AND/OR DANGEROUS CONDITIONS AND ARE NOT COVERED BY THE UNIT WARRANTY.

#### ▲ NOTICE

IN COMPLIANCE WITH RECOGNIZED CODES, IT IS RECOMMENDED THAT AN AUXILIARY DRAIN PAN BE INSTALLED UNDER ALL EVAPORATOR COILS OR UNITS CONTAINING EVAPORATOR COILS THAT ARE LOCATED IN ANY AREA OF A STRUCTURE, ESPECIALLY WHERE DAMAGE TO THE BUILDING OR BUILDING CONTENTS MAY OCCUR AS A RESULT OF AN OVERFLOW OF THE COIL DRAIN PAN OR A STOPPAGE IN THE PRIMARY CONDENSATE DRAIN PIPING.

#### ▲ WARNING

DISCONNECT MAIN ELECTRICAL POWER TO THE UNIT BEFORE ATTEMPTING ANY MAINTENANCE. FAILURE TO DO SO CAN RESULT IN

#### ELECTRICAL SHOCK, SEVERE PERSONAL INJURY OR DEATH.

The blower compartment and motor should be inspected and cleaned periodically by your qualified installer, service agency, or gas supplier to prevent the possibility of overheating due to an accumulation of dust and dirt on the windings or on the motor exterior. As suggested elsewhere in these instructions, the air filters should be kept clean because dirty filters can restrict airflow and the motor depends upon sufficient air flowing across and through it to keep from overheating.

#### IMPORTANT INFORMATION ABOUT EFFICIENCY AND INDOOR AIR QUALITY

Central cooling and heating equipment is only as efficient as the duct system that carries the cooled or heated air. To maintain efficiency, comfort and good indoor air quality, it is important to have the proper balance between the air being supplied to each room and the air returning to the cooling and heating equipment.

Proper balance and sealing of the duct system improves the efficiency of the heating and air conditioning system and improves the indoor air quality of the home by reducing the amount of airborne pollutants that enter homes from spaces where the ductwork and/or equipment is located. The manufacturer and the U.S. Environmental Protection

**DO NOT DESTROY. PLEASE READ CAREFULLY AND KEEP IN A SAFE PLACE FOR FUTURE REFERENCE.**

## **▲ WARNING**

**CARBON MONOXIDE (CO) IS A COLORLESS, ODORLESS, POISONOUS GAS THAT CAN CAUSE SEVERE PERSONAL INJURY OR DEATH. CARBON MONOXIDE CAN BE PRODUCED BY ANY FUEL-BURNING DEVICE, INCLUDING BUT NOT LIMITED TO:**

- MOTOR VEHICLES
- GENERATORS AND OTHER GASOLINE POWERED TOOLS AND ENGINES
- GAS AND FUEL-OIL APPLIANCES
- CHARCOAL OR GAS GRILLS
- WOOD OR GAS FIREPLACES AND STOVES
- OUTDOOR CAMPING EQUIPMENT

**CARBON MONOXIDE FROM ANY ONE OF THESE DEVICES CAN BE INADVERTENTLY DRAWN INTO AND DISTRIBUTED THROUGH THE LIVING SPACE BY THE NORMAL OPERATION OF THE CENTRAL HEATING / AIR CONDITIONING SYSTEM (SEE FIGURE 1).**

**APPLIANCES AND FUEL BURNING DEVICES MUST BE INSTALLED, OPERATED AND MAINTAINED IN ACCORDANCE WITH THE MANUFACTURER'S INSTRUCTIONS.**

**GASOLINE-POWERED TOOLS AND MOTOR VEHICLES MUST NOT BE OPERATED IN ENCLOSED SPACES, SUCH AS BASEMENTS, CRAWL-SPACES, OR GARAGES, EVEN WITH DOORS AND WINDOWS OR VENTS OPEN, AS EXHAUST FUMES INCLUDING CARBON MONOXIDE CAN BUILD UP AND SEEP INTO THE LIVING SPACE THROUGH CRACKS AND OPENINGS IN THE STRUCTURE. TOXIC FUMES, INCLUDING CARBON MONOXIDE, CAN ALSO BE DRAWN INTO THE LIVING SPACE THROUGH OPENINGS AND SEAMS IN THE CENTRAL HEATING AND AIR CONDITIONING EQUIPMENT AND / OR DUCTWORK.**

**FOR THESE REASONS, THE U.S. CONSUMER PRODUCT SAFETY COMMISSION (CPSC) RECOMMENDS THAT EVERY HOME HAVE AT LEAST ONE CARBON MONOXIDE ALARM INSTALLED IN THE HALLWAY NEAR THE BEDROOMS IN EACH SEPARATE SLEEPING AREA OF THE HOME. CARBON MONOXIDE ALARMS SHOULD BE CERTIFIED TO THE REQUIREMENTS OF THE MOST RECENT UL, IAS OR CSA STANDARD, AND SHOULD BE INSTALLED, OPERATED AND MAINTAINED IN ACCORDANCE WITH THE ALARM MANUFACTURER'S INSTRUCTIONS.**

**FIGURE 1**  
**MIGRATION OF DANGEROUS SUBSTANCES, FUMES, AND ODORS INTO LIVING SPACES**

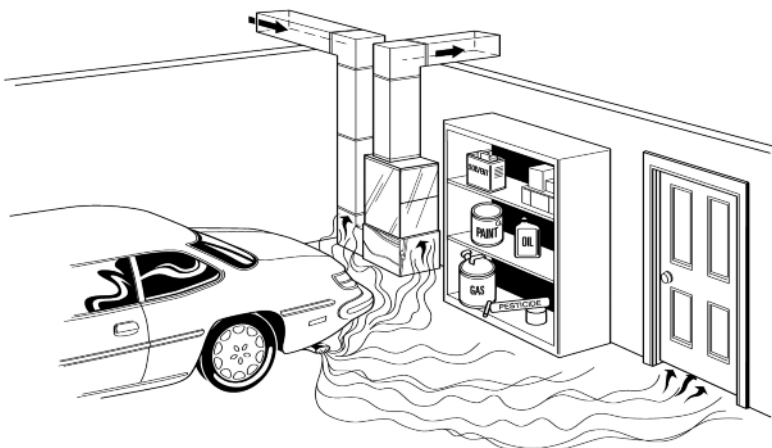

*Adapted from Residential Duct Diagnostics and Repair, with permission of Air Conditioning Contractors of America (ACCA).*

Agency's ENERGY STAR® Program recommend that central duct systems be checked by a qualified contractor for proper balance and sealing.

## **RECEIVING**

Immediately upon receipt, all cartons and contents should be inspected for transit damage. Units with damaged

cartons should be opened immediately. If damage is found, it should be noted on the delivery papers, and a damage claim filed with the last carrier.

- After unit has been delivered to job site, remove carton taking care not to damage unit.
- Check the unit rating plate for unit size, voltage, phase, etc. to be sure equipment matches what is required for the job specification.
- Read the entire instructions before starting the installation.
- Some building codes require extra cabinet insulation and gasketing when unit is installed in attic applications.
- If installed in an unconditioned space, apply caulking around the power wires, control wires, refrigerant tubing and condensate line where they enter the cabinet. Seal the power wires on the inside where they exit conduit opening. Caulking is required to prevent air leakage into and condensate from forming inside the unit, control box, and on electrical controls.
- Install the unit in such a way as to allow necessary access to the coil/filter rack and blower/control compartment.
- Install the unit in a level position to ensure proper condensate drainage. Make sure unit is level in both directions within 1/8".
- Install the unit in accordance with any local code which may apply and the national codes. Latest editions are available from: "National Fire Protection Association, Inc., Batterymarch Park, Quincy, MA 02269." These publications are:
  - ANSI/NFPA No. 70-(Latest Edition) National Electrical Code.
  - NFPA90A Installation of Air Conditioning and Ventilating Systems.
  - NFPA90B Installation of warm air heating and air conditioning systems.
- The equipment has been evaluated in accordance with the Code of Federal Regulations, Chapter XX, Part 3280.

# SYSTEM OPERATION INFORMATION

1. Keep the air filters clean. Your heating system will operate more efficiently, economically and provide better heating.
2. Arrange your furniture and drapes so that the supply air registers and return air grilles are unobstructed.
3. Close doors and windows. This will reduce the heating load on your system.
4. Avoid excessive use of exhaust fans.
5. Do not permit the heat generated by television, lamps, or radios to influence the thermostat operation.

6. If you desire to operate your system with constant air circulation, consult your thermostat manual or please ask advice from a qualified installer, service agency or gas supplier.

During the heating season, the operation of the hydronic air handler is automatic. Your qualified installer or service agency has provided a wall-mounted thermostat which is sensitive to the change in temperature of the air moving around the thermostat. Your thermostat will have switches to select some or all of the following functions:

**HEAT** - Turns heating on when temperature drops below the desired temperature.

**COOL** - Turns cooling on when temperature rises above the desired temperature.

**AUTO** - Turns cooling or heating system on as required to maintain the desired temperature.

**OFF** - Turns heating and cooling modes off. (The blower may still circulate air in the FAN-ON position.)

**FAN-ON** - Turns the blower on for continuous operation.

**FAN-AUTO** - The blower cycles on and off with cooling or heating operation.

## MAINTENANCE

### ▲ WARNING

**DISCONNECT MAIN ELECTRICAL POWER TO THE UNIT BEFORE ATTEMPTING ANY MAINTENANCE. FAILURE TO DO SO CAN CAUSE ELECTRICAL SHOCK RESULTING IN SEVERE PERSONAL INJURY OR DEATH.**

### ▲ CAUTION

**DO NOT OPERATE YOUR SYSTEM FOR EXTENDED PERIODS WITHOUT FILTERS. A PORTION OF THE DUST ENTRAINED IN THE AIR MAY TEMPORARILY LODGE IN THE AIR DUCT RUNS AND AT THE SUPPLY REGISTERS. RECIRCULATION OF THIS TYPE OF RESIDUE WILL SOIL CEILINGS,**

**WALLS, DRAPES, CARPETS, AND OTHER HOUSEHOLD ARTICLES.**

**IT IS RECOMMENDED THAT AN ANNUAL INSPECTION OF YOUR HYDRONIC AIR HANDLER BE DONE BY A QUALIFIED INSTALLER OR SERVICE AGENCY.**

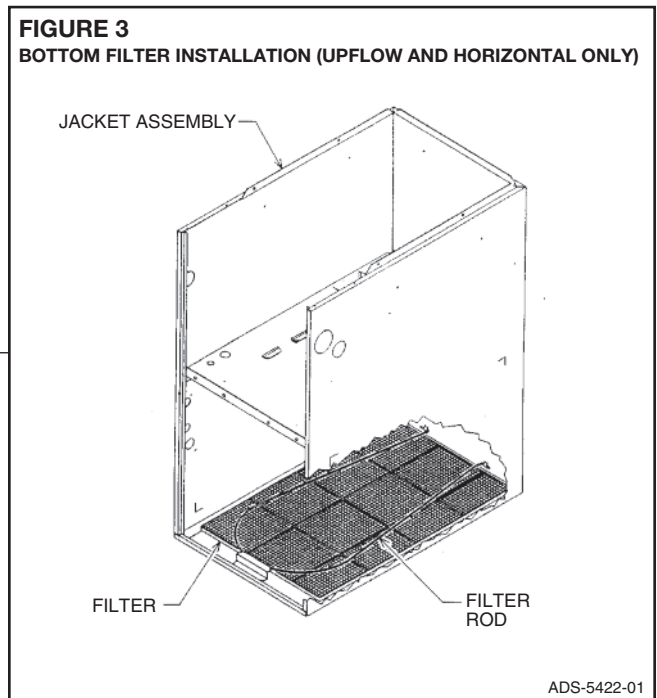
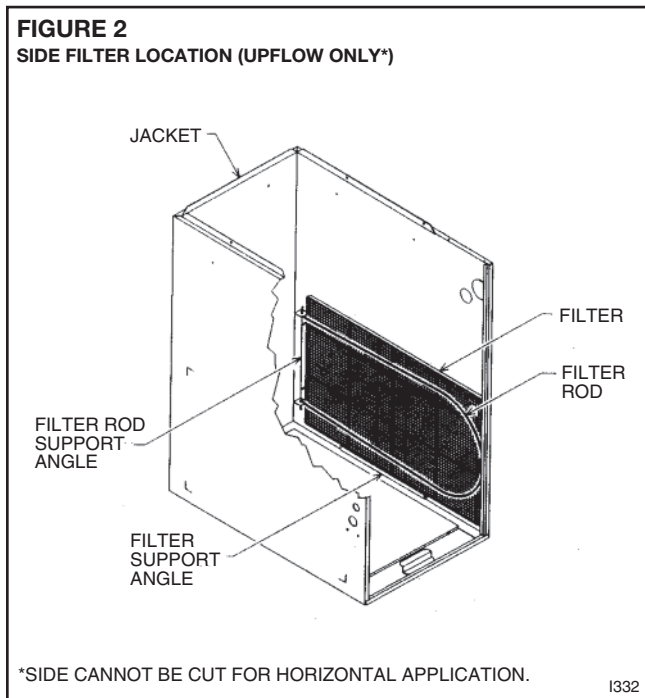

FILTER SIZES				
AIR HANDLER WIDTH	INPUT MBTUH	BOTTOM SIZE	SIDE SIZE	QUANTITY
17½"	60	15¾" X 25"	15¾" X 25"	1
24½"	80, 100	22¾" x 25"	15¾" x 25"	1

**FIGURE 4**  
**HORIZONTAL FILTERS LOCATION**

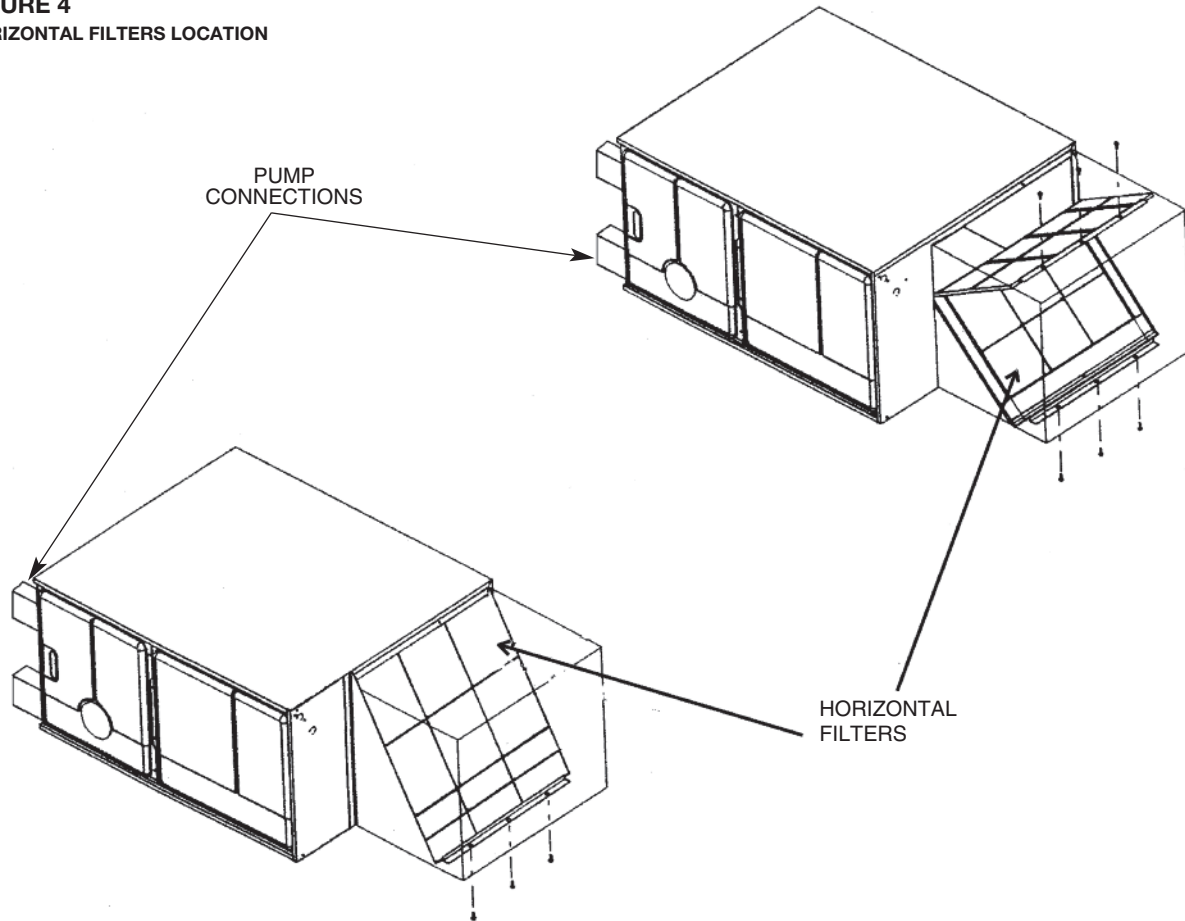

## FILTER MAINTENANCE

Have your qualified installer or service agency instruct you on how to access your filters for regular maintenance.

### **▲ WARNING**

**TURN OFF ELECTRICAL POWER TO HYDRONIC AIR HANDLER BEFORE REMOVING FRONT ACCESS DOOR. FAILURE TO DO SO CAN RESULT IN ELECTRICAL SHOCK, SEVERE PERSONAL INJURY OR DEATH.**

Keep air filters clean at all times. Vacuum dirt from filter, wash with detergent and water, air dry thoroughly, and reinstall.

After filters are cleaned and returned to the hydronic air handler, be sure doors are properly reinstalled. If you are not totally sure of this procedure, consult a qualified installer, service agency or the gas supplier.

## REMOVING FILTERS

HYDRONIC AIR HANDLER - FILTER IN BOTTOM OR SIDE LOCATION

1. Remove the blower compartment access door.
2. Disengage the filter retaining rod and pull filter out.
3. Clean filter and reinstall.
4. Replace the blower compartment access door.

## ROUTINE MAINTENANCE

**Routine maintenance to be provided by a qualified installer, service agency, or gas supplier ONLY.**

## LUBRICATION

The blower motor and pump motor are prelubricated by the manufacturer and, beyond suggested maintenance, do not require further attention.

**IMPORTANT: DO NOT** attempt to lubricate the bearings on the blower motor or pump motor. Addition of lubricants can reduce the motor life and void the warranty.