

INSTALLATION INSTRUCTIONS

AIR HANDLERS

FEATURING INDUSTRY STANDARD R-410A REFRIGERANT 

(-)H2T High Efficiency 2-Stage with Aluminum Coil (Constant Torque Motor)

(-)H2V High Efficiency 2-Stage with Aluminum Coil (Constant CFM Motor)

(-)H2V High Efficiency Variable Speed with Aluminum Coil

All Models Equipped with Rheem EcoNet™ Communications



RECOGNIZE THIS SYMBOL AS AN INDICATION OF IMPORTANT SAFETY INFORMATION!

WARNING

These instructions are intended as an aid to qualified licensed service personnel for proper installation, adjustment and operation of this unit. Read these instructions thoroughly before attempting installation or operation. Failure to follow these instructions may result in improper installation, adjustment, service or maintenance possibly resulting in fire, electrical shock, property damage, personal injury or death.



ISO 9001:2008
Certificate Number: 30164

DO NOT DESTROY THIS MANUAL

PLEASE READ CAREFULLY AND KEEP IN A SAFE PLACE FOR FUTURE REFERENCE BY A SERVICEMAN



TABLE OF CONTENTS

1.0 SAFETY INFORMATION	4
2.0 GENERAL INFORMATION	6
2.1 Important Information About Efficiency & Indoor Air Quality.....	6
2.2 Checking Product Received	7
2.3 Model Number Nomenclature	7
2.4 Available Models	8
2.5 Dimensions & Weights	9
2.6 Importance of Proper Indoor/Outdoor Match-Ups	10
2.7 Importance of a Quality Installation.....	10
3.0 INSTALLATION	11
3.1 Tools & Refrigerant.....	11
3.1.1 Tools Required for Installing & Servicing R-410A Models.....	11
3.1.2 Specifications of R-410A.....	11
3.1.3 Quick Reference Guide for R-410A	11
3.2 Applications & Orientation	12
3.2.1 Vertical Upflow & Horizontal Left Discharge	12
3.2.2 Vertical Downflow & Horizontal Right Discharge	12
3.2.3 Installation in an Unconditioned Space	14
3.2.4 Installation in Mobile/Manufactured Homes	15
3.2.5 Installation in Corrosive Environments	16
3.2.6 Supporting Air-Handler in Horizontal Applications	16
3.3 Auxiliary Overflow Pan	16
3.4 Clearances	16
3.5 Duct Flanges	16
3.6 Ductwork	17
3.7 Return Air Filter	18
3.8 Refrigerant Line Connections & Charging	18
3.8.1 Preparation	18
3.8.2 Liquid Line Filter Drier.....	18
3.8.3 Brazing.....	18
3.8.4 Leak Testing.....	19
3.8.5 Evacuation	19
3.8.6 Refrigerant Charging	19
3.9 EXV Vapor Line Thermistor/TXV Sensing Bulb Attachment	19
3.10 Condensate Drain	21
3.11 EcoNet™ Control Center or Thermostat	22
3.12 Electrical Wiring.....	23
3.12.1 Configuring Unit for 208 Volt Power.....	23
3.12.2 Grounding	23
3.12.3 Power Wiring.....	23
3.12.4 Copper Wire Size.....	23
3.12.5 Electrical Data – Blower Motor Only Without Electric Heat... 24	
3.12.5.1 (-)H2T	24
3.12.5.2 (-)H2V/(-)H2V.....	24
3.12.6 Electrical Data – With Electric Heat	25
3.12.6.1 (-)H2T	25
3.12.6.2 (-)H2V/(-)H2V.....	28
3.12.7 Electric Heater Kit Supplemental Information	30
3.12.8 EcoNet™ Communications Control Wiring.....	31
3.12.9 Auxiliary Switch Inputs.....	31
3.12.10 Conventional 24VAC Thermostat Control Wiring	32
3.12.11 Conventional 24VAC Thermostat Control Wiring Connection Diagrams . 33	
3.13 Air-Flow	37
3.13.1 General Air-Flow Operating Limits.....	37
3.13.2 (-)H2T Indoor Blower Motor Speed Selection.....	38
3.13.3 (-)H2T Air-Flow Performance Data.....	39
3.13.4 (-)H2V/(-)H2V Air-Flow Settings Overview.....	42
3.13.5 (-)H2V/(-)H2V Cooling & Heat Pump Heating Air-Flow Settins	42
3.13.6 (-)H2V/(-)H2V Cooling Air-Flow Trim Adjustment	44
3.13.7 (-)H2V/(-)H2V Electric Heat Air-Flow Settings	44
3.13.8 (-)H2V/(-)H2V Cooling Mode Dehumidification	45
3.13.9 Using the On-Board LED to Determine Blower CFM: (-)H2V/(-)H2V Only	46

TABLE OF CONTENTS (continued)

4.0 START-UP	46
4.1 Pre-Start Checklist	46
4.2 System Start-Up and Operational Check-Out	47
4.3 EcoNet™ Communication Verification	47
4.4 Sequence of Operation	47
4.4.1 Cooling Mode (-)H2T	47
4.4.2 Cooling Mode (-)H2V	47
4.4.3 Cooling Mode (-)H2V	48
4.4.4 Electric Heat Mode (-)H2T	48
4.4.5 Electric Heat Mode (-)H2V/()H2V	48
4.4.6 Heat Pump Heating Mode (-)H2T	48
4.4.7 Heat Pump Heating Mode (-)H2V	49
4.4.8 Heat Pump Heating Mode (-)H2V	49
4.4.9 Supplemental Heating During Defrost	50
4.4.10 Emergency Heat (Heat Pump)	50
4.4.11 Thermostat Fan Setting	50
4.5 Correcting Electric Heat kW for Voltage	50
4.6 Calculating Electric Heat Capacity in BTUH	50
4.7 Checking Air-Flow	50
4.7.1 Estimating CFM Using External Static Pressure: (-)H2T	50
4.7.2 Estimating CFM On-Board LED to Determine Blower CFM: (-)H2V/(-)H2V Only	51
4.7.3 Estimating CFM Using Electric Heat Temperature Rise	51
4.8 Checking Refrigerant Charge	51
5.0 COMPONENTS & CONTROLS	51
5.1 EcoNet™ Air-Handler Control Board	51
5.2 Blower Motor	54
5.2.1 Constant Torque ECM Motor: (-)H2T	54
5.2.2 Variable Speed ECM Motor: (-)H2V/(-)H2V	54
5.3 Electronic Expansion Valve (EXV)	55
5.3.1 EXV Overview	55
5.3.2 Factory Cooling Superheat Settings	55
5.3.3 Cooling Superheat Offset DIP Switch Settings	55
5.3.4 EXV Step DIP Switch Settings	56
5.3.5 EXV Diagnostic LED's	56
5.4 Vapor Line Temperature Sensor (Thermistor)	56
5.5 Suction Pressure Transducer	56
5.6 Thermal Expansion Valve (TXV)	56
5.7 Blower	56
5.8 Transformer	56
5.9 Indoor Coil Assembly	56
6.0 ACCESSORIES & KITS	57
6.1 Electric Resistance Heater Kits	57
6.2 Jumper Bar Kits	58
6.3 Auxiliary Horizontal Overflow Pans	58
6.4 External Filter Bases	58
6.5 Combustible Floor Bases	58
6.6 Horizontal Adapter Kits	58
6.7 Supply and Return Air Temperature Sensor Kit	59
7.0 MAINTENANCE	59
7.1 Air-Filter	59
7.2 Indoor Coil, Drain Pan, Drain Line	59
7.3 Blower Motor & Wheel	59
7.4 Motor Lubrication	59
7.5 Blower Assembly Removal & Replacement	60
7.6 Motor Replacement	60
7.7 Motor Control Module Replacement	61
7.8 Blower Wheel Replacement	61
7.9 EcoNet™ Air-Handler Control Board Replacement	62
7.10 Replacement Parts	62
8.0 DIAGNOSTICS	63
8.1 General Diagnostics	63
8.2 EcoNet™ Air-Handler Control Board Diagnostic Codes	64
9.0 WIRING DIAGRAMS	65
9.1 (-)H2T With EXV	65
9.2 (-)H2T With TXV	66
9.3 (-)H2V/(-)H2V	67

⚠ WARNING (SEE SECTION 3.12: ELECTRICAL WIRING)

Disconnect all power to unit before installing or servicing. More than one disconnect switch may be required to de-energize the equipment. Hazardous voltage can cause severe personal injury or death.

⚠ WARNING (SEE SECTION 7.5: BLOWER ASSEMBLY REMOVAL & REPLACEMENT)

If removal of the blower assembly is required, all disconnect switches supplying power to the equipment must be de-energized and locked (if not in sight of unit) so the field power wires can be safely removed from the blower assembly. Failure to do so can cause electrical shock resulting in personal injury or death.

⚠ WARNING

Because of possible damage to equipment or personal injury, installation, service, and maintenance should be performed by a trained, qualified service personnel. Consumer service is recommended only for filter cleaning/replacement. Never operate the unit with the access panels removed.

1.0 SAFETY INFORMATION

⚠ WARNING

Duct leaks can create an unbalanced system and draw pollutants such as dirt, dust, fumes and odors into the home causing property damage. Fumes and odors from toxic, volatile or flammable chemicals, as well as automobile exhaust and carbon monoxide (CO), can be drawn into the living space through leaking ducts and unbalanced duct systems causing personal injury or death (see Figure 1).

- If air-moving equipment or ductwork is located in garages or off-garage storage areas - all joints, seams, and openings in the equipment and duct must be sealed to limit the migration of toxic fumes and odors including carbon monoxide from migrating into the living space.
- If air-moving equipment or ductwork is located in spaces containing fuel burning appliances such as water heaters or boilers - all joints, seams, and openings in the equipment and duct must also be sealed to prevent depressurization of the space and possible migration of combustion byproducts including carbon monoxide into the living space.

⚠ WARNING

These instructions are intended as an aid to qualified, licensed service personnel for proper installation, adjustment and operation of this unit. Read these instructions thoroughly before attempting installation or operation. Failure to follow these instructions may result in improper installation, adjustment, service or maintenance possibly resulting in fire, electrical shock, property damage, personal injury or death.

⚠ WARNING (SEE SECTION 3.2.2: VERTICAL DOWNFLOW)

The RXHB-17, RXHB-21 or RXHB-24 combustible floor base is required when some units with electric heat are applied downflow on combustible flooring. Failure to use the base can cause a fire resulting in property damage, personal injury or death. See **CLEARANCES** for units requiring a combustible floor base. See the accessory section in this manual for combustible floor base RXHB.

⚠ WARNING (SEE SECTION 3.12.2: GROUNDING)

The unit must be permanently grounded. Failure to do so can result in electrical shock causing personal injury or death.

⚠ WARNING (SEE SECTION 7.0: MAINTENANCE)

Units with circuit breaker(s) meet requirements as a service disconnect switch, however, if access is required to the line side (covered) of the circuit breaker, this side of the breaker(s) will be energized with the breaker(s) de-energized. Contact with the line side can cause electrical shock resulting in personal injury or death.

⚠ WARNING (SEE SECTION 3.6: DUCTWORK)

Do not, under any circumstances, connect return ductwork to any other heat producing device such as fireplace insert, stove, etc. Unauthorized use of such devices may result in fire, carbon monoxide poisoning, explosion, personal injury or property damage.

Continued on next page >

WARNING

PROPOSITION 65: This appliance contains fiberglass insulation. Respirable particles of fiberglass are known to the State of California to cause cancer.

All manufacturer products meet current Federal OSHA Guidelines for safety. California Proposition 65 warnings are required for certain products, which are not covered by the OSHA standards.

California's Proposition 65 requires warnings for products sold in California that contain or produce any of over 600 listed chemicals known to the State of California to cause cancer or birth defects such as fiberglass insulation, lead in brass, and combustion products from natural gas.

All "new equipment" shipped for sale in California will have labels stating that the product contains and/or produces Proposition 65 chemicals. Although we have not changed our processes, having the same label on all our products facilitates manufacturing and shipping. We cannot always know "when, or if" products will be sold in the California market.

You may receive inquiries from customers about chemicals found in, or produced by, some of our heating and air-conditioning equipment, or found in natural gas used with some of our products. Listed below are those chemicals and substances commonly associated with similar equipment in our industry and other manufacturers.

- Glass Wool (Fiberglass) Insulation
- Carbon Monoxide (CO).
- Formaldehyde
- Benzene

More details are available at the websites for OSHA (Occupational Safety and Health Administration), at www.osha.gov and the State of California's OEHHA (Office of Environmental Health Hazard Assessment), at www.oehha.org. Consumer education is important since the chemicals and substances on the list are found in our daily lives. Most consumers are aware that products present safety and health risks, when improperly used, handled and maintained.

WARNING (SEE SECTION 3.7: AIR FILTER)

Do not operate the system without filters. A portion of the dust entrained in the air may temporarily lodge in the duct runs and at the supply registers. Any circulated dust particles could be heated and charred by contact with the heating elements. This residue could soil ceilings, walls, drapes, carpets and other articles in the house.

Soot damage may occur even with filters in place when certain types of candles, oil lamps or standing pilots are burned.

WARNING

The first 36 inches of supply air plenum and ductwork must be constructed of sheet metal as required by NFPA 90B. The supply air plenum or duct must have a solid sheet metal bottom directly under the unit with no openings, registers or flexible air ducts located in it. If flexible supply air ducts are used they may be located only in the vertical walls of a rectangular plenum, a minimum of 6 inches from the solid bottom. Metal plenum or duct may be connected to the combustible floor base, if not, it must be connected to the unit supply duct flanges such that combustible floor or other combustible material is not exposed to the supply air opening from the downflow unit. Exposing combustible (non-metal) material to the supply opening of a downflow unit can cause a fire resulting in property damage, personal injury or death.

Exceptions to downflow warnings:

- Installations on concrete floor slab with supply air plenum and ductwork completely encased in not less than 2 inches of concrete (See NFPA 90B).

CAUTION (SEE SECTION 3.2.2: VERTICAL DOWNFLOW & HORIZONTAL RIGHT DISCHARGE)

Unit must be reconfigured for vertical down or horizontal right supply air discharge applications. The coil must be repositioned so the vertical drainpan is on the bottom for vertical down discharge applications or the horizontal drip pan is below coil for horizontal right discharge applications. Failure to reconfigure the unit for these applications can result in property damage and poor system performance.

CAUTION (SEE SECTION 3.3: AUXILIARY OVERFLOW PAN)

In compliance with recognized codes, an auxiliary drain pan must be installed under all equipment containing evaporator coils that are located in any area of a structure where damage to the building or building contents may occur as a result of an overflow of the coil drain pan or a stoppage in the primary condensate drain piping. See Section 6.3 of this manual for auxiliary horizontal overflow pan accessory information (model RXBM).

NOTICE

When used in cooling applications, excessive sweating may occur when unit is installed in an unconditioned space. This can result in property damage.

NOTICE

Improper installation, or installation not made in accordance with the Underwriters Laboratory (UL) certification or these instructions, can result in unsatisfactory operation and/or dangerous conditions and are not covered by the unit warranty.

▲ NOTICE

Use of this air-handler during construction is not recommended. If operation during construction is absolutely required, the following temporary installation requirements must be followed:

Installation must comply with all Installation Instructions in this manual including the following items:

- Properly sized power supply and circuit breaker/fuse
- Air-handler operating under thermostatic control;
- Return air duct sealed to the air-handler;
- Air filters must be in place;
- Correct air-flow setting for application
- Removing the coil and storing it in a clean safe place is highly recommended until construction is completed and the outdoor unit is installed.
- Clean air-handler, duct work, and components including coil upon completion of the construction process and verify proper air-handler operating conditions according as stated in this instruction manual.
- NOTE: Electric strip heater elements tend to emit a burning odor for a few days if dust has accumulated during construction. Heater elements are easily damaged. Take great care when cleaning them. Low pressure compressed air is recommended for cleaning elements.

FIGURE 1
MIGRATION OF DANGEROUS SUBSTANCES, FUMES, AND ODORS INTO LIVING SPACES

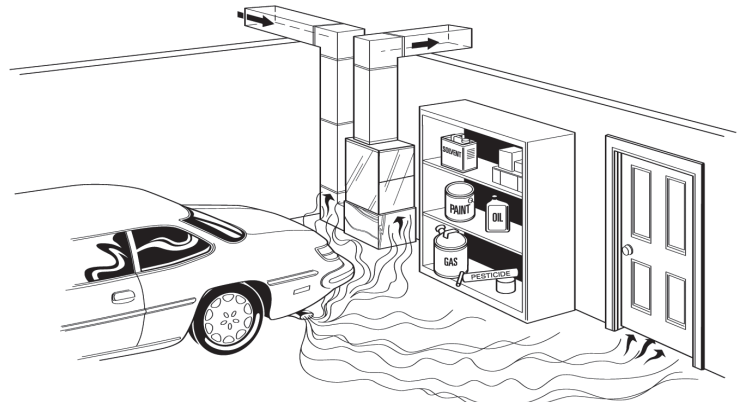

Adapted from *Residential Duct Diagnostics and Repair*, with permission of Air Conditioning Contractors of America (ACCA).

! WARNING



Carbon Monoxide (CO) Poisoning Can Cause Severe Injury or Death.

Carbon Monoxide from the exhaust of motor vehicles and other fuel burning devices can be drawn into the living space by the operation of the central heating and air conditioning system.

Exhaust from motor vehicles, generators, garden tractors, mowers, portable heaters, charcoal and gas grills, gasoline powered tools, and outdoor camping equipment contains carbon monoxide, a poisonous gas that can kill you. You cannot see it, smell it, or taste it.

- Do NOT operate an automobile or any engine in a garage for more than the few seconds it takes to enter or exit the garage.
- Do NOT operate any fuel-burning device in an enclosed or partly enclosed space, or near building windows, doors or air intakes.

The U.S. Consumer Product Safety Commission (CPSC) and Health Canada recommend the installation of UL or CSA certified Carbon Monoxide Alarm(s) in every home.

▲ WARNING

Duct leaks can create an unbalanced system and draw pollutants such as dirt, dust, fumes and odors into the home causing property damage. Fumes and odors from toxic, volatile or flammable chemicals, as well as automobile exhaust and carbon monoxide (CO), can be drawn into the living space through leaking ducts and unbalanced duct systems causing personal injury or death (see Figure 1).

- If air-moving equipment or ductwork is located in garages or off-garage storage areas - all joints, seams, and openings in the equipment and duct must be sealed to limit the migration of toxic fumes and odors including carbon monoxide from migrating into the living space.
- If air-moving equipment or ductwork is located in spaces containing fuel burning appliances such as water heaters or boilers - all joints, seams, and openings in the equipment and duct must also be sealed to prevent depressurization of the space and possible migration of combustion byproducts including carbon monoxide into the living space.

▲ NOTICE

Improper installation, or installation not made in accordance with the Underwriters Laboratory (UL) certification or these instructions, can result in unsatisfactory operation and/or dangerous conditions and are not covered by the unit warranty.

2.0 GENERAL INFORMATION

2.1 IMPORTANT INFORMATION ABOUT EFFICIENCY & INDOOR AIR QUALITY

Central cooling and heating equipment is only as efficient as the duct system that carries the cooled or heated air. To maintain efficiency, comfort and good indoor air quality,

it is important to have the proper balance between the air being supplied to each room and the air returning to the cooling and heating equipment.

Proper balance and sealing of the duct system improves the efficiency of the heating and air conditioning system and improves the indoor air quality of the home by reducing the amount of airborne pollutants that enter homes from spaces where the ductwork and/or equipment is located. The manufacturer and the U.S. Environmental Protection Agency's Energy Star Program recommend that central duct systems be checked by a qualified contractor for proper balance and sealing.

2.2 CHECKING PRODUCT RECEIVED

Immediately upon receipt, all cartons and contents should be inspected for transit damage. Units with damaged cartons should be opened immediately. If damage is found, it should be noted on the delivery documents and a damage claim filed with the delivering carrier.

After unit has been delivered to the job site, remove the unit from the carton taking care not to damage the unit. Check the unit rating plate for unit model number, unit size, coil model, voltage, phase, etc. to assure the unit matches the job specifications.

2.3 MODEL NUMBER NOMENCLATURE

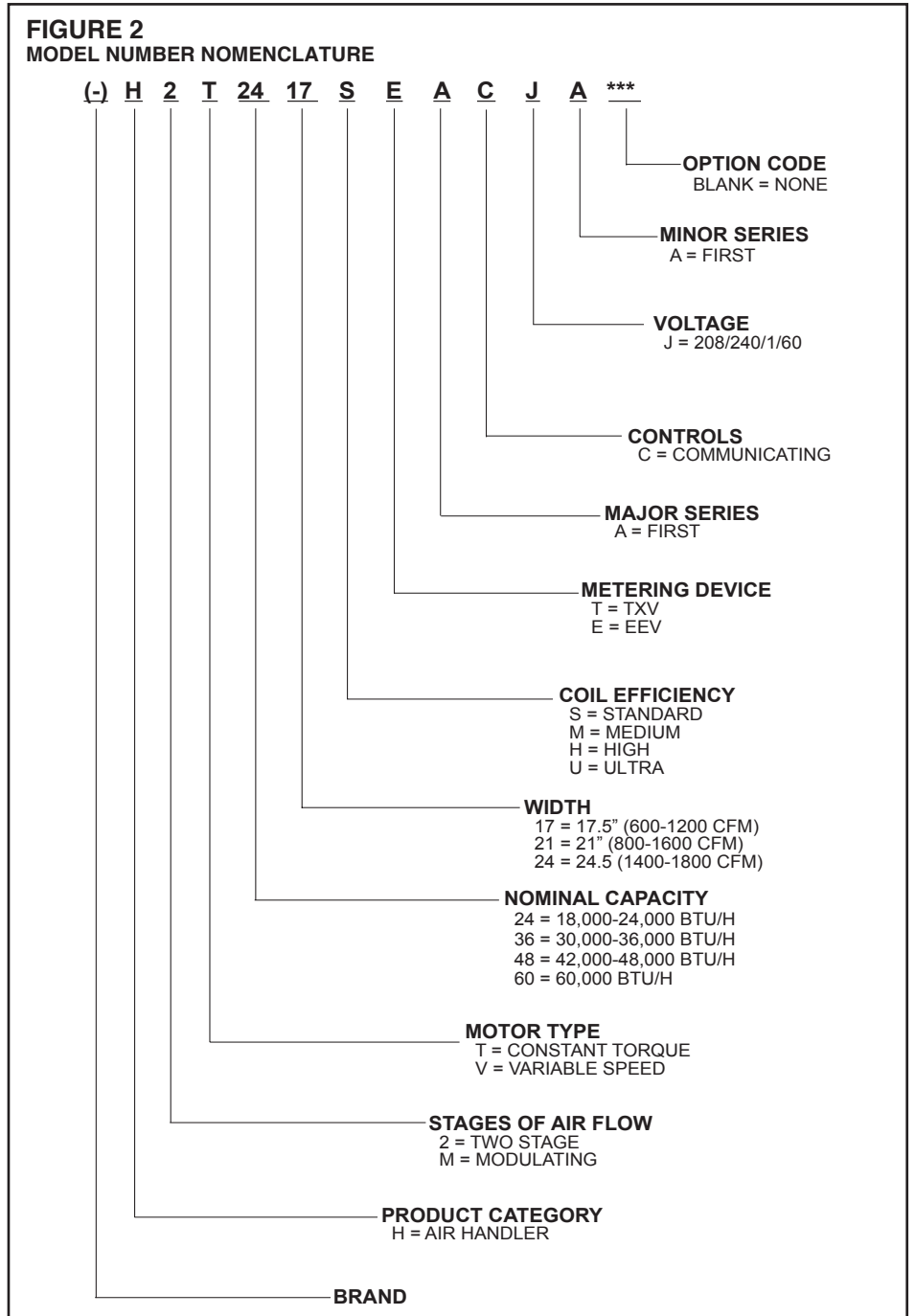

2.4 AVAILABLE MODELS

AVAILABLE MODELS: J VOLTAGE

(-)H2T2417SEACJA
(-)H2T2421MEACJA
(-)H2T3617SEACJA
(-)H2T3621MEACJA
(-)H2T4821MEACJA
(-)H2T6021SEACJA
(-)H2T6024MEACJA
(-)H2V2417SEACJA
(-)H2V2421MEACJA
(-)H2V2421HEACJA
(-)H2V2421UEACJA
(-)H2V3617SEACJA
(-)H2V6021SEACJA
(-)H2V6024MEACJA

(-)H2T2417STACJA
(-)H2T2421MTACJA
(-)H2T3621MTACJA
(-)H2T4821MTACJA
(-)H2T6024MTACJA
(-)H2V2417STACJA
(-)H2V2421MTACJA
(-)H2V3621MTACJA
(-)H2V4821MTACJA
(-)H2V6021STACJA
(-)H2V6024STACJA
(-)H2V6024MTACJA

Notes:

- Supply circuit protective devices may be fuses or “HACR” type circuit breakers.
- Largest motor load is included in single circuit and multiple circuit 1.
- The air handlers are shipped from the factory with the proper indoor coil installed, and cannot be ordered without a coil.
- The air handlers do not have an internal filter rack. An external filter rack or other means of filtration is required.

2.5 DIMENSIONS & WEIGHTS

FIGURE 3
DIMENSIONS AND WEIGHTS

NOTE: 24" CLEARANCE REQUIRED IN FRONT OF UNIT FOR FILTER AND COIL MAINTENANCE.

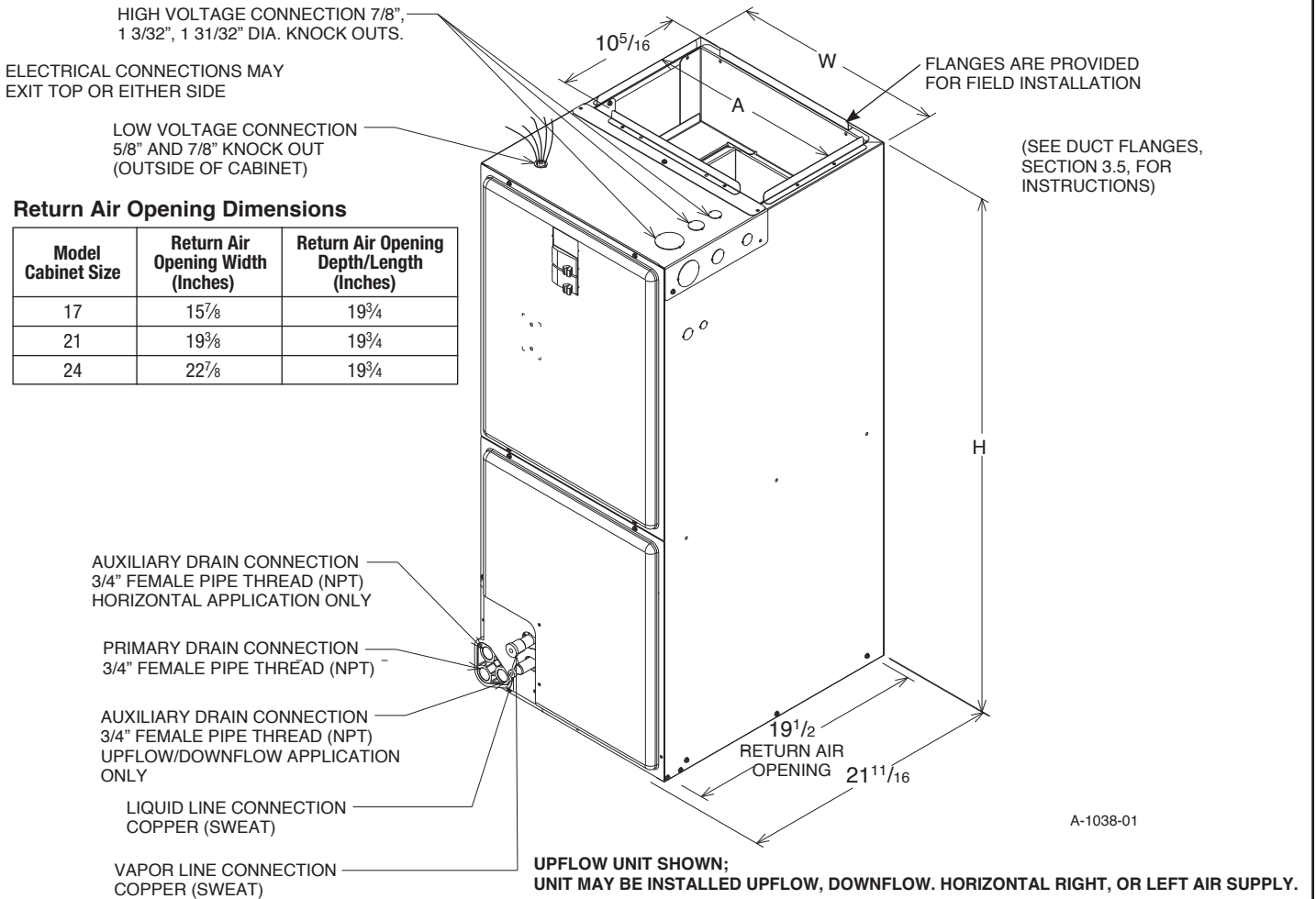

A-1038-01

DIMENSIONAL DATA

MODEL SIZE (-)H2T	REFRIGERANT CONNECTIONS		UNIT HEIGHT IN. [mm]	UNIT WIDTH "W" IN. [mm]	SUPPLY DUCT "A" IN. [mm]	UNIT WEIGHT / SHIPPING WEIGHT (LBS.) [kg]
	SWEAT (IN.) [MM] ID					UNIT WITH COIL (MAX. kW.)
	LIQUID	VAPOR				
2417S	3/8" [9.53]	3/4" [19.05]	42 ¹ / ₂ " [1080]	17 ¹ / ₂ " [444.5]	16" [406.4]	92/106 [42/48]
2421M	3/8" [9.53]	3/4" [19.05]	42 ¹ / ₂ " [1080]	21" [533.4]	19 ¹ / ₂ " [495.3]	111/126 [50/57]
3617S	3/8" [9.53]	3/4" [19.05]	42 ¹ / ₂ " [1080]	17 ¹ / ₂ " [444.5]	16" [406.4]	96/110 [44/50]
3621M	3/8" [9.53]	3/4" [19.05]	50 ¹ / ₂ " [1283]	21" [533.4]	19 ¹ / ₂ " [495.3]	129/145 [59/66]
4821M	3/8" [9.53]	7/8" [22.23]	57" [1448]	21" [533.4]	19 ¹ / ₂ " [495.3]	141/153 [64/69]
6021S	3/8" [9.53]	7/8" [22.23]	57" [1448]	21" [533.4]	19 ¹ / ₂ " [495.3]	141/153 [64/69]
6024M	3/8" [9.53]	7/8" [22.23]	55 ¹ / ₂ " [1410]	24 ¹ / ₂ " [622.3]	23" [584]	161/178 [73/81]

MODEL SIZE (-)H2V/(-)HMV	REFRIGERANT CONNECTIONS		UNIT HEIGHT IN. [mm]	UNIT WIDTH "W" IN. [mm]	SUPPLY DUCT "A" IN. [mm]	UNIT WEIGHT / SHIPPING WEIGHT (LBS.) [kg]
	SWEAT (IN.) [MM] ID					UNIT WITH COIL (MAX. kW.)
	LIQUID	VAPOR				
2417S	3/8" [9.53]	3/4" [19.05]	42 ¹ / ₂ " [1080]	17 ¹ / ₂ " [444.5]	16" [406.4]	92/106 [42/48]
2421M	3/8" [9.53]	3/4" [19.05]	42 ¹ / ₂ " [1080]	21" [533.4]	19 ¹ / ₂ " [495.3]	111/126 [50/57]
2421H	3/8" [9.53]	7/8" [22.23]	50 ¹ / ₂ " [1283]	21" [533.4]	19 ¹ / ₂ " [495.3]	130/146 [59/66]
2421U	3/8" [9.53]	7/8" [22.23]	57" [1448]	21" [533.4]	19 ¹ / ₂ " [495.3]	141/153 [64/69]
3617S	3/8" [9.53]	3/4" [19.05]	42 ¹ / ₂ " [1080]	17 ¹ / ₂ " [444.5]	16" [406.4]	96/110 [44/50]
3621M	3/8" [9.53]	3/4" [19.05]	50" [1283]	21" [533.4]	19 ¹ / ₂ " [495.3]	129/145 [59/66]
4821M	3/8" [9.53]	7/8" [22.23]	57" [1448]	21" [533.4]	19 ¹ / ₂ " [495.3]	141/153 [64/69]
6021S	3/8" [9.53]	7/8" [22.23]	57" [1448]	21" [533.4]	19 ¹ / ₂ " [495.3]	141/153 [64/69]
6024M	3/8" [9.53]	7/8" [22.23]	55 ¹ / ₂ " [1410]	24 ¹ / ₂ " [622.3]	23" [584]	161/178 [73/81]

2.6 IMPORTANCE OF PROPER INDOOR/OUTDOOR MATCH-UPS

To assure many years of reliable operation and optimum customer comfort and to assure the outdoor unit warranty remains valid, an air-handler model should be selected that is properly matched to the outdoor unit. This is especially critical for heat pump systems to assure proper refrigerant charge balance between the cooling and heating modes. The recommended approach is to select an air-handler model that has an AHRI match with the outdoor unit. Refer to the AHRI directory at www.ahridirectory.org to confirm the air-handler and outdoor unit are a certified combination in the AHRI Directory.

2.7 IMPORTANCE OF QUALITY INSTALLATION

A quality installation is critical to assure safety, reliability, comfort, and customer satisfaction. Strict adherence to applicable codes, the information in this installation manual, the outdoor unit installation manual, and the thermostat installation manual are key to a quality installation. Read the entire instruction manuals before starting the installation.

IMPORTANT: This product has been designed and manufactured to meet certified AHRI capacity and efficiency ratings with the appropriate outdoor units. However, proper refrigerant charge, proper airflow, and refrigerant line sizing are critical to achieve optimum capacity and efficiency and to assure reliable operation. Installation of this product should follow the manufacturer's refrigerant charging and airflow instructions located in the outdoor unit installation instructions and the charging chart label affixed to the outdoor unit. Failure to confirm proper charge and airflow may reduce energy efficiency and shorten equipment life.

The equipment has been evaluated in accordance with the Code of Federal Regulations, Chapter XX, Part 3280.

Install the unit in accordance with applicable national, state, and local codes. Latest editions are available from: "National Fire Protection Association, Inc., Batterymarch Park, Quincy, MA 02269." These publications are:

- ANSI/NFPA No. 70-(Latest Edition) National Electrical Code.
- NFPA90A Installation of Air Conditioning and Ventilating Systems.
- NFPA90B Installation of warm air heating and air conditioning systems.

Install the unit in such a way as to allow necessary access to the coil/filter rack and blower/control compartment.

3.0 INSTALLATION

3.1 TOOLS & REFRIGERANT

3.1.1 TOOLS REQUIRED FOR INSTALLING AND SERVICING R-410A MODELS

Manifold Sets:

- Up to 800 PSIG High-Side
- Up to 250 PSIG Low-Side
- 550 PSIG Low-Side Retard

Manifold Hoses:

- Service Pressure Rating of 800 PSIG

Recovery Cylinders:

- 400 PSIG Pressure Rating
- Dept. of Transportation 4BA400 or BW400

 NOTICE
R-410A systems operate at higher pressures than R-22 systems. Do not use R-22 service equipment or components on R-410A equipment.

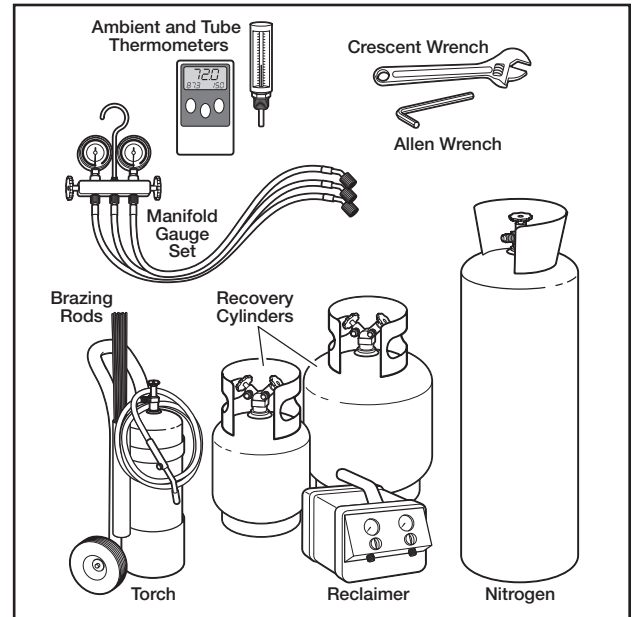

3.1.2 SPECIFICATIONS OF R-410A

Application: R-410A is not a drop-in replacement for R-22. Equipment designs must accommodate its higher pressures. It cannot be retrofitted into R-22 heat pumps.

Physical Properties: R-410A has an atmospheric boiling point of -62.9°F [-52.7°C] and its saturation pressure at 77°F [25°C] is 224.5 psig.

Composition: R-410A is a near-azeotropic mixture of 50% by weight difluoromethane (HFC-32) and 50% by weight pentafluoroethane (HFC-125).

Pressure: The pressure of R-410A is approximately 60% (1.6 times) greater than R-22. Recovery and recycle equipment, pumps, hoses, and the like must have design pressure ratings appropriate for R-410A. Manifold sets need to range up to 800 psig high-side and 250 psig low-side with a 550 psig low-side retard. Hoses need to have a service pressure rating of 800 psig. Recovery cylinders need to have a 400 psig service pressure rating, DOT 4BA400 or DOT BW400.

Combustibility: At pressures above 1 atmosphere, a mixture of R-410A and air can become combustible. R-410A and air should never be mixed in tanks or supply lines or be allowed to accumulate in storage tanks. Leak checking should never be done with a mixture of R-410A and air. Leak-checking can be performed safely with nitrogen or a mixture of R-410A and nitrogen.

3.1.3 QUICK-REFERENCE GUIDE FOR R-410A

- R-410A refrigerant operates at approximately 60% higher pressure (1.6 times) than R-22. Ensure that servicing equipment is designed to operate with R-410A.
- R-410A refrigerant cylinders are light rose in color.
- R-410A, as with other HFCs, is only compatible with POE oils.
- Vacuum pumps will not remove moisture from POE oil used in R-410A systems.
- R-410A systems are to be charged with liquid refrigerants. Prior to March 1999, R-410A refrigerant cylinders had a dip tube. These cylinders should be kept upright for equipment charging. Post-March 1999 cylinders do not have a dip tube and should be inverted to ensure liquid charging of the equipment.
- Do not install a suction line filter drier in the liquid line.
- A factory-approved outdoor liquid line filter drier is shipped with every unit and must be installed in the liquid line at the time of installation. If only the air-handler is being replaced on an existing system, the existing filter drier must be replaced at the time of installation with a field supplied filter drier. **IMPORTANT:** A bi-flow filter drier must be used for heat pump applications. Filter driers must be rated for minimum working pressure of 600 psig. The filter drier will only have adequate moisture-holding capacity if the system is properly evacuated.
- Desiccant (drying agent) must be compatible for POE oils and R-410A refrigerant.

3.2 APPLICATIONS AND ORIENTATION

3.2.1 VERTICAL UPFLOW & HORIZONTAL LEFT DISCHARGE

- Vertical Upflow & Horizontal Left Discharge is the factory configuration for all models (see Figure 4).
- The return air plenum must be large enough to supply unit and strong enough to support unit weight.
- If return air is to be ducted through the floor, install duct flush with floor. Use fireproof resilient gasket 1/8 to 1/4 in. thick between duct, unit and floor. Set unit on floor over opening.

IMPORTANT: Do not cut the side out of air-handler cabinet for a side return duct as this will result in the return air bypassing the coil. Instead, install air-handler on top of a field supplied sheet metal or wooden box and run the side return duct into the side of the box.

FIGURE 4
DIMENSIONS FOR REFRIGERANT-TUBING & DRAIN CONNECTIONS

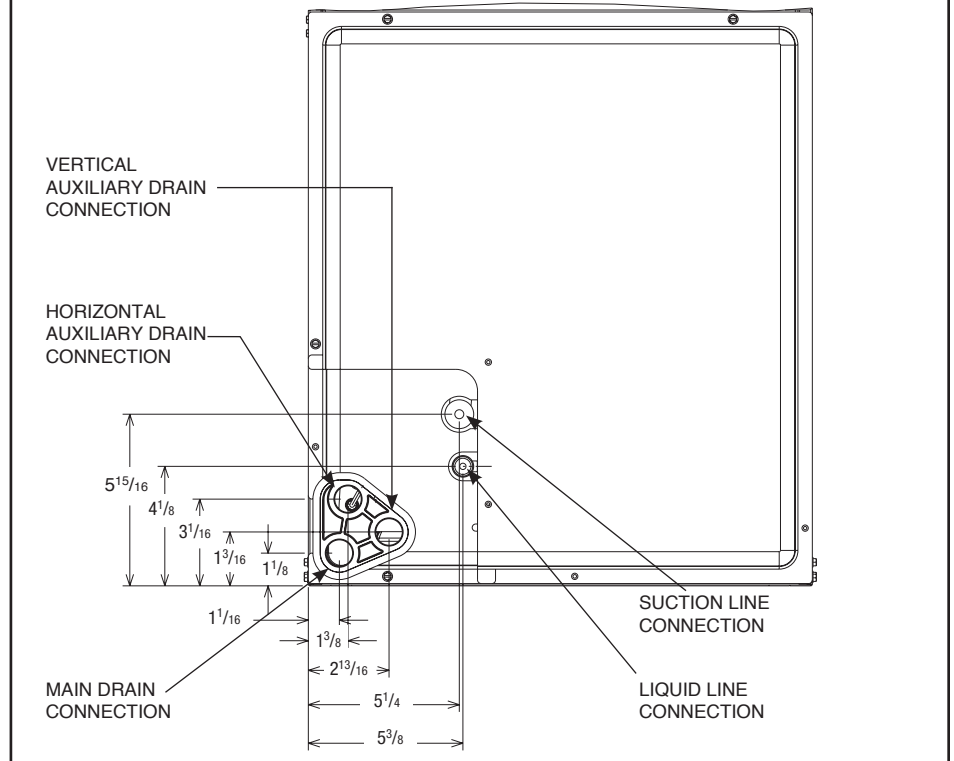

3.2.2 VERTICAL DOWNFLOW & HORIZONTAL RIGHT DISCHARGE

The unit as shipped from the factory is not configured for vertical down or horizontal right discharge applications and must be converted in the field to work in those applications. To make this conversion, remove the coil door and slide the indoor coil out of the cabinet.

When converting the air-handler for vertical down and horizontal right discharge applications, an additional set of 2 coil support rails must be installed before the coil can be reinstalled. These additional rails are supplied with the air-handler and are packaged with the duct flanges. Six screws are also provided for mounting the rails and can be found in the installation hardware bag. Clearance holes must be drilled in the sides of the cabinet for the mounting screws using the provided dimples as guides. Note that the shorter coil support rail with no notch must be mounted on the left-hand side to provide clearance for the drainpan condensate connection boss.

The vertical down/horizontal right coil support rails were not installed at the factory so the insulation under them would not be compressed which could result in exterior cabinet sweating in humid environments due to that location being in the cold downstream side of the indoor coil in vertical up and horizontal left discharge applications. The coil support rails installed at the factory should be left in place to help retain the cabinet insulation. They will be located on the warmer return side of the air-handler for down and horizontal right discharge applications and will therefore not pose a risk for cabinet sweating.

Once the additional coils support rails are installed, slide the coil back into the cabinet 180° from its original position, ensuring the retaining channel is fully engaged with the coil rail. (See Figure 6, Detail A.) Leave the coil door off until after the refrigerant tubing is brazed to the refrigerant stubs to allow TXV to be wrapped with a wet rag or heat sink compound during the brazing process. If the air-handler is not already in position, it can now be positioned so the blower discharge is either down or to the right depending on the application.

FIGURE 5
ROTATING CIRCUIT BREAKER

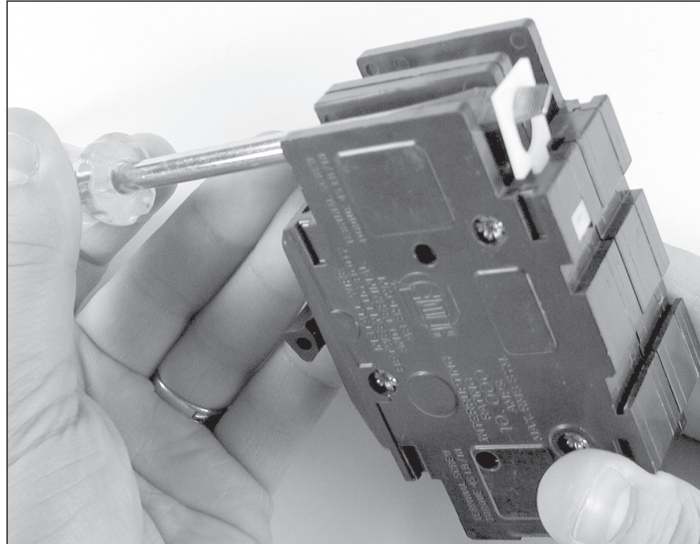

DRIP LOOP NOTE: When installing the unit in down or horizontal right discharge applications, make sure the wires going to the blower motor form a proper drip loop to force any condensate that might form on the wires to drip off the lowest point of the wiring instead of entering the motor or motor control. This may require cutting the wire-tie and installing a new wire-tie to form a new drip loop.

IMPORTANT: To comply with certification agencies and the National Electric Code for down discharge applications, the circuit breaker(s) on field-installed electric heater kits must be re-installed per procedure below so that the breaker switch “on” position and marking is up and the “off” position and marking is down.

- To turn breaker(s): Rotate one breaker pair (circuit) at a time starting with the one on the right. Loosen both lugs on the load side of the breaker. Wires are bundles with wire ties, one bundle going to the right lug and one bundle going to the left lug.
- Using a screwdriver or pencil, lift white plastic tab with hole away from breaker until breaker releases from mounting opening (see Figure 5).
- With breaker held in hand, rotate breaker so that “on” position is up and the “off” position is down with unit in the vertical mounting position. Insert right wire bundle into top right breaker lug, ensuring all strands of all wires are inserted fully into lug, and no wire insulation is caught in lug.
- Tighten lug as tight as possible while holding circuit breaker. Check wires and make sure each wire is secure and none are loose. Repeat for left wire bundle in left top circuit breaker lug.

IMPORTANT: Failure to securely hold the breaker will result in the plastic mounting boss on the breaker to be broken off when the lug is tightened.

- Replace breaker by inserting breaker mounting tab opposite white pull tab in opening, hook mounting tab over edge in opening.
- With screwdriver or pencil, pull white tab with hole away from breaker while setting that side of breaker into opening. When breaker is in place, release tab, locking circuit breaker into location in opening.
- Repeat above operation for remaining breaker(s) (if more than one is provided).
- If one is used, replace the single point wiring jumper bar on line side of breaker and tighten securely.
- Double check wires and lugs to make sure all are secure and tight. Check to make sure unit wiring to circuit breaker load lugs match that shown on the unit wiring diagram.

⚠ WARNING

The RXHB-17, RXHB-21 or RXHB-24 combustible floor base is required when some units with electric heat are applied downflow on combustible flooring. Failure to use the base can cause a fire resulting in property damage, personal injury or death. See CLEARANCES (Section 3.4) for units requiring a combustible floor base. See the accessory section in this manual for combustible floor base RXHB.

IMPORTANT: Units cannot be installed horizontally laying on or suspended from the back of the unit.

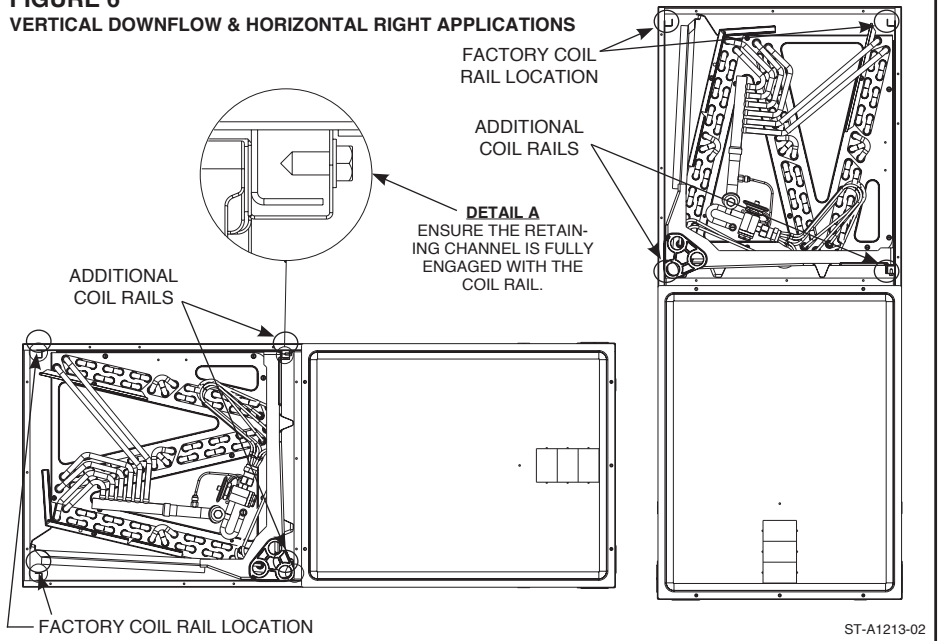
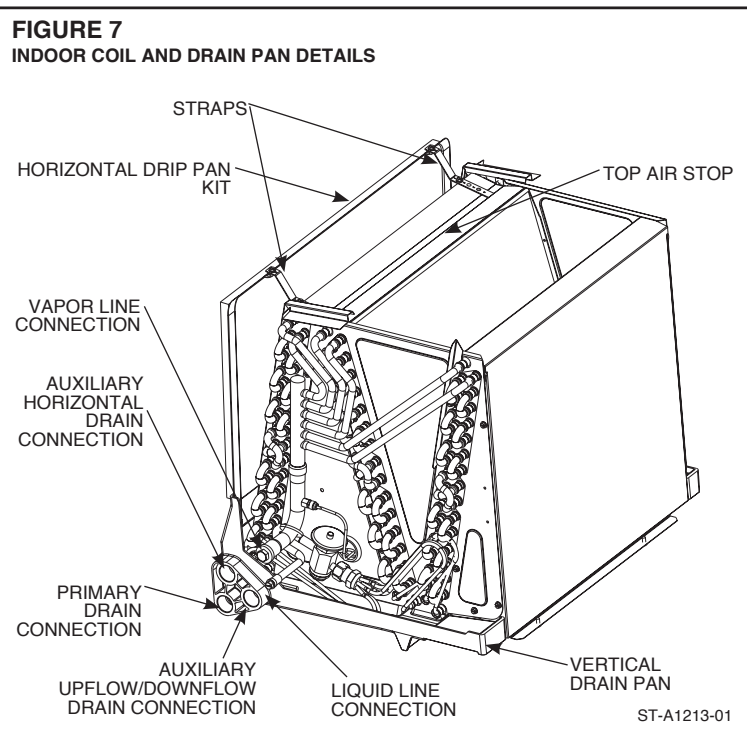
FIGURE 6**VERTICAL DOWNFLOW & HORIZONTAL RIGHT APPLICATIONS****FIGURE 7****INDOOR COIL AND DRAIN PAN DETAILS****CAUTION**

Auxiliary horizontal overflow pan kits RXBM- (or equivalent) are required when the unit is configured for the horizontal position over a finished ceiling and/or living space. (See Sections 3.3 and 6.3.) Failure to install overflow pan can result in property damage.

3.2.3 INSTALLATION IN AN UNCONDITIONED SPACE

The exterior cabinet of an air handler has a greater risk of sweating when installed in an unconditioned space than when it is installed in the conditioned space. This is primarily due to the temperature of the conditioned air moving through the air handler and the air circulating around the unit where it is installed. For this reason, the following is recommended for all air handler applications, but special attention should be paid to those installed in unconditioned spaces:

- Duct sizing and airflow are critical and must be based on the equipment selected.
- Supply and return duct attachment: If other than the factory flanges are used, the attachment of ducting must be insulated and tight to prevent sweating.

- No perimeter supply flanges are provided. If a full perimeter supply duct is used, it is the responsibility of the installer to provide duct flanges as needed, to secure and seal the supply duct to prevent air leakage and the sweating that will result.
- Apply caulking around all cabinet penetrations such as power wires, control wires, refrigerant tubing and condensate line where they enter the cabinet. Seal the power wires on the inside where they exit conduit opening. Sealing is required to prevent air leakage into the unit which can result in condensate forming inside the unit, control box, and on electrical controls. Take care not to damage, remove or compress insulation when applying the caulk.
- In some cases, the entire air handler can be wrapped with insulation. This can be done as long as the unit is completely enclosed in insulation, sealed and service access is provided to prevent accumulation of moisture inside the insulation wrap.
- An auxiliary overflow pan is recommended to protect the structure from excessive cabinet sweating or a restricted coil drain line. (See Section 3.3)
- If an electric heater kit is installed, be sure the breaker or disconnect cover is sealed tightly to the door panel.

3.2.4 INSTALLATION IN MOBILE/MANUFACTURED HOMES

1. Air handler must be secured to the structure using “L” brackets or pipe strap.
2. Allow a minimum of 24 inches (610 mm) front clearance required to access doors.
3. Recommended method for securing air handler:
 - A. If air handler is against the wall, secure top of air handler to wall stud using two 16ga thick angle brackets one on each side. Attach brackets with No. 10 self-tapping 1/2” long screws to air handler and use 5/16” lag screws 1 1/2” long to wall stud. Secure bottom of unit with two 16ga “L” brackets with No. 10 self-tapping 1/2” long screws to air handler and use 5/16” lag screws 1 1/2” long to floor.
 - B. If air handler is away from wall attach pipe strap to top of air handler using No. 10 1/2” long self-tapping screws on both sides. Angle strap down and away from back of air handler, remove all slack, and fasten to wall stud of structure using 5/16” lag screws 1 1/2” long. Secure bottom of unit with two 16ga “L” brackets with No. 10 self-tapping screws to air handler and use 5/16” lag screws 1 1/2” long to floor.

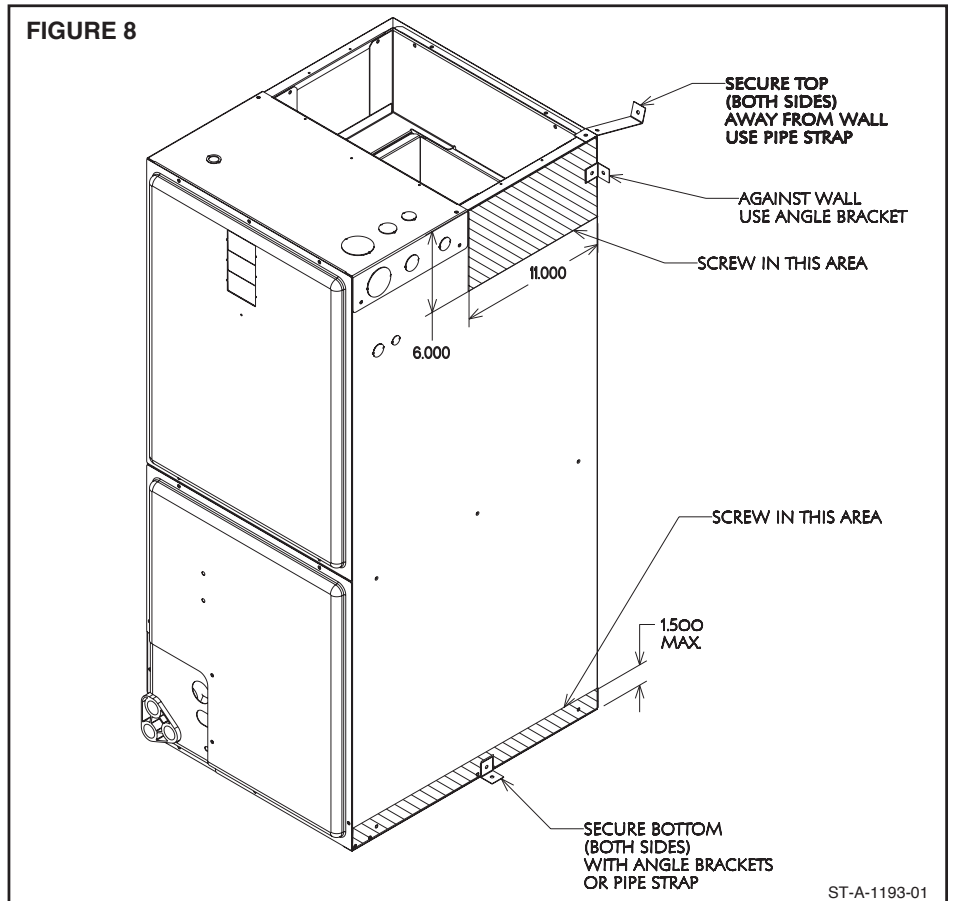

3.2.5 INSTALLATION IN CORROSIVE ENVIRONMENTS

The metal parts of this unit may be subject to rust or deterioration if exposed to a corrosive environment which can shorten its life. In addition to exposure to the exterior of the cabinet, chemical contaminants inside the building that can be drawn into the unit from the return air grille and attack structural metal parts, electrical components and the indoor coil, causing premature failure of the unit. If the unit is to be installed in an area where contaminants are likely to be a problem, special attention should be given to isolate the unit and return grille from contaminants.

3.2.6 SUPPORTING AIR-HANDLER IN HORIZONTAL APPLICATIONS

The air-handler must be adequately supported underneath if it is installed in the horizontal position to prevent it from sagging in the middle which can cause issues removing and re-installing the access panels. Position the unit on adequate supports or on support angles or channels (See Figure 9) before connecting ductwork to the unit. If an auxiliary overflow pan is required (See Section 3.3), the overflow pan will need to be adequately supported with the air-handler being supported underneath within the auxiliary overflow pan by angles and/or channels.

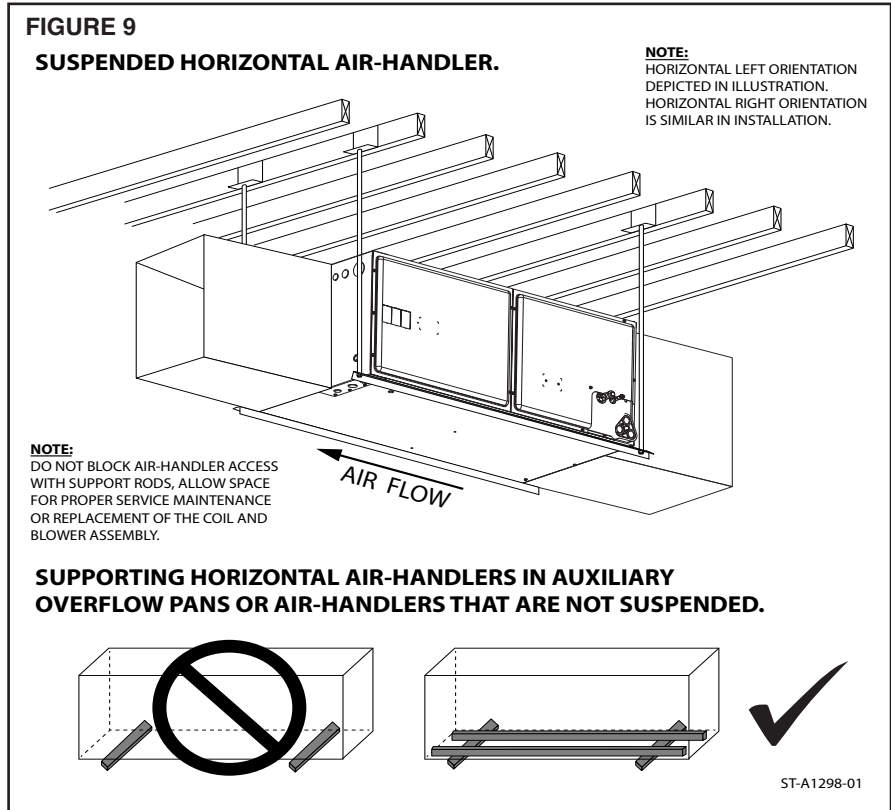

3.3 AUXILIARY OVERFLOW PAN

In compliance with recognized codes, an auxiliary overflow pan must be installed under all equipment containing evaporator coils that are located in any area of a structure where damage to the building or building contents may occur as a result of an overflow of the coil drain pan or a stoppage in the primary condensate drain piping. See Section 6.3 of this manual for information regarding the recommended auxiliary horizontal overflow pan (model RXBM) for this air-handler.

3.4 CLEARANCES

- All units are designed for “0” inches clearance to combustible material on all cabinet surfaces except for downflow application with higher kW electric heat as noted below.
- Some units require a combustible floor base depending on the heating kW if installed in the downflow configuration on a combustible surface. The following table should be used to determine these requirements.

Model Cabinet Size	17	21	24
Maximum Model Designation kW	15	18	20

- Units with electric heating kW equal to or less than the values listed in the table do not require a combustible floor base. See Section 6.5 for Combustible Floor Base RXHB-XX.
- Units with electric heat require a one inch clearance to combustible material for the first three feet of supply plenum and ductwork.
- Vertical downflow applications require clearance on at least one side of the unit for electrical connections. Refrigerant and condensate drain connections are made on

the front of the unit.

- All units require 24 inches minimum access to the front of the unit for service.
- These units may be installed in either ventilated or nonventilated spaces.

3.5 DUCT FLANGES

Duct flanges (4 pieces) are shipped with the unit and are to be field installed on the top of the air-handler using the following procedure and referring to Figure 10.

1. Loosen the screws attaching the heat barrier to the cabinet.
2. Form a 90° bend with the short leg length at approximately 9.9" from the end where the slot is cut in the flange to facilitate bending. The duct flanges are shipped sized for the 24.5" wide cabinet. For the 17.5" and 21" wide cabinets, cut the long leg as shown in Figure 10 to match the cabinet width.
3. Slide the duct flanges onto the screws loosened in step one above. Tighten the screws to secure the flanges.

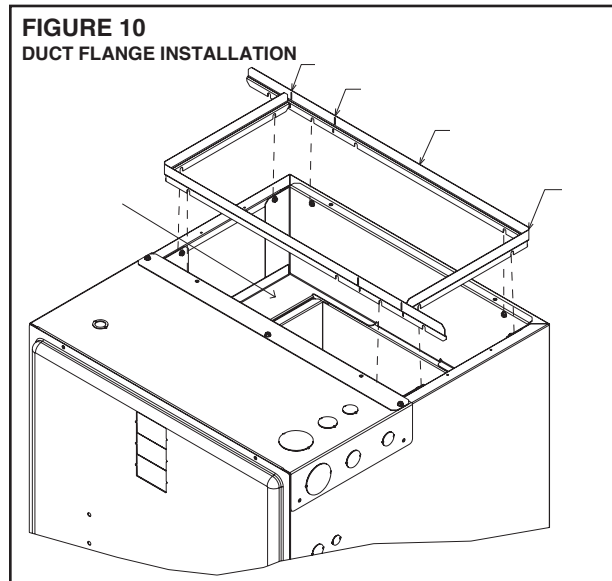

3.6 DUCTWORK

Field ductwork must comply with the National Fire Protection Association NFPA 90A, NFPA 90B and any applicable local ordinance.

WARNING

Do not, under any circumstances, connect return ductwork to any other heat producing device such as fireplace insert, stove, etc. Unauthorized use of such devices may result in fire, carbon monoxide poisoning, explosion, personal injury or property damage.

Sheet metal ductwork run in unconditioned spaces must be insulated and covered with a vapor barrier. Fibrous ductwork may be used if constructed and installed in accordance with SMACNA Construction Standard on Fibrous Glass Ducts. Ductwork must comply with National Fire Protection Association as tested by U/L Standard 181 for Class I Air Ducts. Check local codes for requirements on ductwork and insulation.

- Duct system must be designed within the range of external static pressure the unit is designed to operate against. It is important that the system airflow be adequate. Make sure supply and return ductwork, grills, filters, accessories, etc. are accounted for in total resistance. Refer to the airflow performance tables in this manual to determine the available external static pressure for the particular air-handler model being installed.
- Design the duct system in accordance with "ACCA" Manual "D" Design for Residential Winter and Summer Air Conditioning and Equipment Selection. Latest editions are available from: "ACCA" Air Conditioning Contractors of America, 1513 16th Street, N.W., Washington, D.C. 20036. If duct system incorporates **flexible air duct**, be sure **pressure drop** information (straight length plus all turns) shown in "ACCA" Manual "D" is accounted for in system.
- Supply plenum is attached to the duct flanges supplied with the unit. See Section 3.5.
- **IMPORTANT:** If an elbow is included in the plenum close to the unit, it must not be smaller than the dimensions of the supply duct flange on the unit.
- **IMPORTANT:** The front flange on the return duct if connected to the blower casing must not be screwed into the area where the power wiring is located. Drills or sharp screw points can damage insulation on wires located inside unit.
- Secure the supply and return ductwork to the unit flanges, using proper fasteners for the type of duct used and tape or caulk the duct-to-unit joint as required to prevent air leaks.

WARNING

Do not operate the system without filters. A portion of the dust entrained in the air may temporarily lodge in the duct runs and at the supply registers. Any circulated dust particles could be heated and charred by contact with the heating elements. This residue could soil ceilings, walls, drapes, carpets and other articles in the house. Operating the system without a filter will also allow lint and dirt particles to accumulate on the indoor coil fin and restrict air-flow through the coil. Soot damage may occur even with filters in place when certain types of candles, oil lamps or standing pilots are burned.

3.7 RETURN AIR FILTER

An internal filter rack is not provided with this air-handler. Therefore, an external means of filtering the return air is required. External filters should be sized for a maximum of 300 feet/min air velocity or the maximum velocity recommended by the type of filter installed. One or more return air filter grilles, a filter rack attached to unit return air intake, or a filter rack installed between a sealed return air platform and the return duct are all acceptable means of filtration. All return ducts must be filtered, either at each return grille or at a common filter near the unit.

Important: Do not install a return air filter grille **and** a filter rack at the unit and do not install a filter in the supply duct system.

Filter type, sizing, and placement are critical to heating and cooling system performance. Reduced air-flow can shorten the life of system components such as the compressor, indoor coil, heater elements, over temperature limits, and relays. As filters near the end of their useful life, the pressure drop through them increases. Therefore, it is important to factor the “end of life” (dirty) pressure drop of filters into the external static pressure of the duct system when selecting blower speeds and designing ductwork to assure the system is operating at the design CFM and system reliability is not compromised. Always verify that the system’s air-flow is within specifications by performing a temperature rise (heating mode) and/or temperature drop (cooling mode) with all filters in place.

Important: High efficiency pleated filters and electronic air cleaners typically have significantly higher pressure drop than standard efficiency fiberglass filters, especially when they get dirty. Do not use high efficiency filters or electronic air cleaners unless adequate filter area is provided to lower the filter pressure drop to an acceptable level.

3.8 REFRIGERANT LINE CONNECTIONS & CHARGING

3.8.1 PREPARATION

The coil is shipped with a low pressure (5-10 psig) charge of dry nitrogen which will be released when the rubber plugs are removed. Leave the rubber plugs in the refrigerant connection stubs on the air-handler until the refrigerant lines are ready to be brazed to the refrigerant connection stubs to prevent contaminants from entering the coil. Clean the ends of the tubing and coil connection stubs (inside and outside) with an alcohol wipe before inserting the line set tubes into the coil connection stubs to assure a quality leak-free braze joint.

Refer to the outdoor unit installation instructions for details on refrigerant line sizing and installation. Be sure to follow long line length guidelines if they apply.

Route the refrigerant tubing in a manner that does not block service access to the front of the air-handler.

3.8.2 LIQUID LINE FILTER DRIER

A new liquid filter drier must be installed every time any part of the system has been open to the atmosphere, even if it’s for a short period of time. The filter drier should be installed close to the air-handler for a system started up in the cooling mode and near the outdoor unit for a heat pump system started up in the heating mode. This allows the filter drier to catch any contaminants in the liquid line before they can enter the indoor or outdoor TXV inlet screen.

3.8.3 BRAZING

Air inside the tubing and coil should be displaced with dry nitrogen prior to the brazing process to prevent the formation of harmful copper oxide inside the tubing. It is very important not to pressurize the system with nitrogen while brazing or pin-hole leaks will form in the braze joint. This is accomplished by removing the gauge port valve core on one of the outdoor unit service valves to allow the pressure to be relieved as the heated nitrogen expands. Fill the system with dry nitrogen through the other service valve gauge port and then turn the nitrogen flow off just before brazing is begun.

Protect the TXV or EXV, copper to aluminum suction header joint, and outdoor unit service valves from overheating using a wet rag or heat sink compound. Leave the wet rag or heat sink material in place until the joint and surrounding tubing cools down to a safe temperature. Double tip torches can help minimize brazing time and heat conduction to the heat sensitive components if the flame is turned down and held on the joint just long enough to make the braze joint. With both single and double tip torches, turning the

flame up too much and keeping the flame on the joint too long will damage the heat sensitive components even when a wet rag or heat sink compound is used.

Use a sheet metal shield to protect the cabinet's paint from the torch flames during the brazing process. The vapor line insulation should be pushed back on the line about 12 inches from the joint and retained to prevent it from igniting or melting during the brazing process.

After the refrigerant brazed connections are made at the air-handler and the tubing has cooled down sufficiently, replace the coil section access panel if it has been removed and seal the air gap around the connection stubs with the foam rubber gasket included in the air-handler parts bag. Peel the self-adhesive backing off of the foam gasket and position it around the stubs with the adhesive side toward the cabinet, then press it firmly against the cabinet. The gasket is split to allow it to go over the stubs after the refrigerant tubes are brazed to the stubs. (See Figure 12B in Section 3.9)

After the foam gasket has been installed, the vapor line insulation should be pulled back in place so it contacts the air-handler cabinet to prevent condensate from forming on the cold tube and dripping off. A loosely fitting zip-tie placed around the insulation ½" from the end can be used to hold it in place so it doesn't move away from the cabinet. For air-handlers with TXV's, a section of the insulation will need to be cut out to make room for the externally mounted TXV bulb. (See Section 3.9) Once the bulb is mounted, insulate the bulb with the foam insulation included in the air-handler parts bag, making sure none of the vapor line is uninsulated.

3.8.4 LEAK TESTING

After all braze joints are completed, replace the valve core removed when purging with nitrogen and then leak test the system by pressurizing to 150 psig with dry nitrogen and allow the system to sit for at least 15 minutes (longer if possible) to assure the pressure does not drop.

3.8.5 EVACUATION

If no leaks are detected, evacuate the system down to 500 microns or below before charging the system or opening the service valves on the outdoor unit which will release the charge stored in the outdoor unit into the line set and air-handler coil. Failure to reach 500 microns of vacuum is a sign of a leak or excessive moisture inside the system.

3.8.6 REFRIGERANT CHARGING

Once the evacuation process is completed, break the vacuum with the refrigerant from a refrigerant cylinder or with refrigerant stored in the outdoor unit by opening the outdoor unit service valves. The charging process cannot be completed until the remaining steps in the installation process are completed and the indoor air-flow is adjusted to the proper level. See Section 4.7 for further details.

3.9 EXV VAPOR LINE THERMISTOR/TXV SENSING BULB ATTACHMENT

IMPORTANT: DO NOT perform any brazing with the vapor line thermistor or TXV sensing bulb attached to any line. After brazing operations have been completed, clamp the vapor line thermistor or TXV bulb securely on the vapor line at the 10 to 2 o'clock position (see Figures 11 and 12) with the clip provided on the thermistor or TXV clamp provided in the air-handler parts bag. Insulate the vapor line thermistor or TXV sensing bulb and vapor line with the provided pressure sensitive insulation (size 4" x 7") and secure with provided wire ties.

IMPORTANT: Vapor line thermistor or TXV sensing bulb should be located on a horizontal section of vapor line, just outside of coil box. The copper thermistor must never be placed on any aluminum tube as this will result in galvanic corrosion and eventual failure of the aluminum tube.

IMPORTANT: Never place the thermistor or sensing bulb on the heat effected zone near the braze connection, but it should be located within 6" of the indoor unit.

FIGURE 11A
THERMISTER LOCATION

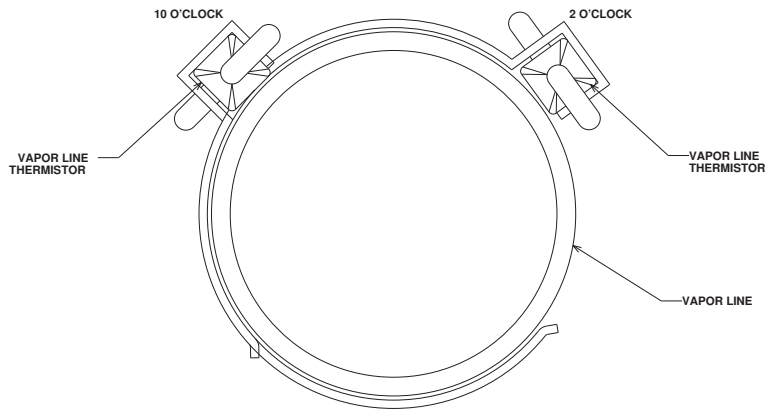

FIGURE 11B
TXV BULB LOCATION

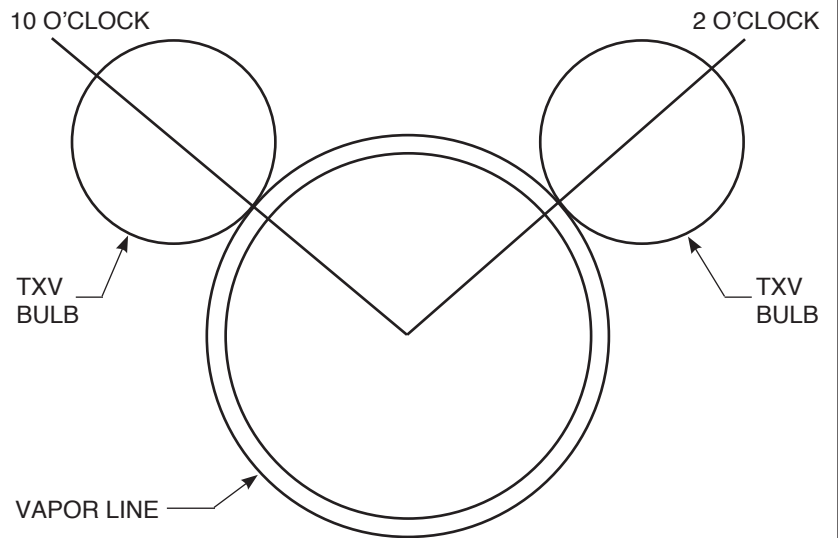

FIGURE 12A
THERMISTER LOCATION

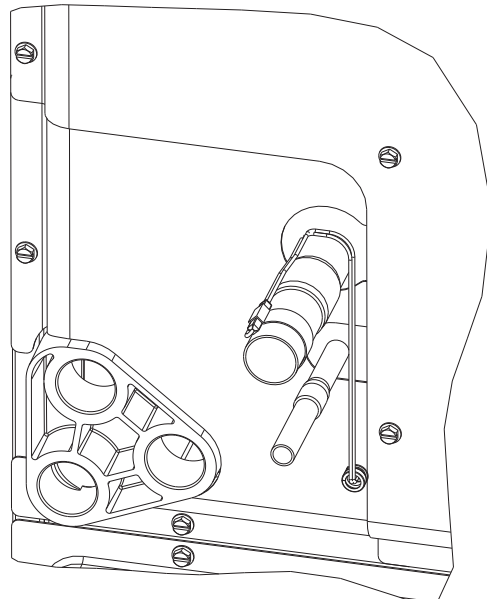
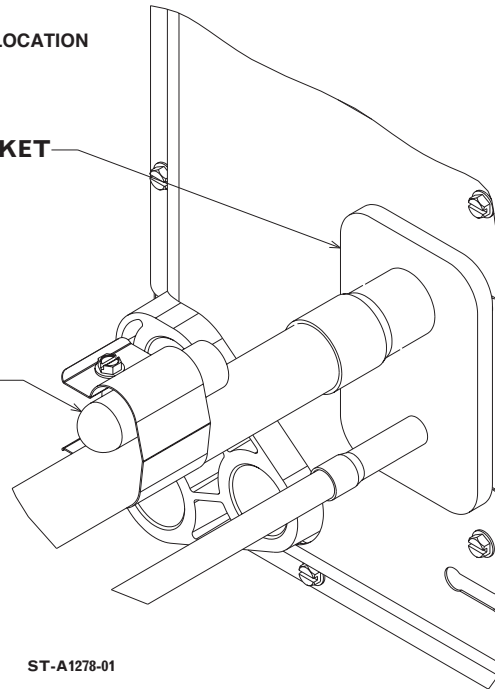

FIGURE 12B
TXV BULB & FOAM GASKET LOCATION

FOAM GASKET

TXV BULB



ST-A1278-01

3.10 CONDENSATE DRAIN

Consult local codes or ordinances for specific requirements.

IMPORTANT: When making drain fitting connections to the drain pan, use a thin layer of Teflon paste, silicone or Teflon tape and install hand tight.

IMPORTANT: When making drain fitting connections to drain pan, do not overtighten. Overtightening fittings can split pipe connections on the drain pan.

- Install drain lines so they do not block service access to front of the unit. Minimum clearance of 24 inches is required for filter, coil or blower removal and service access.
- Although the condensate drain pan is designed to be self draining, it is recommended that the air-handler cabinet be pitched slightly downward toward the primary drain connection to assure the condensate drains completely from the drain pan. The downward pitch should be approximately 1/8" per foot and in both axes.
- Do not reduce drain line size less than connection size provided on condensate drain pan.
- All drain lines must be pitched downward away from the unit a minimum of 1/8" per foot of line to ensure proper drainage.
- Do not connect condensate drain line to a closed or open sewer pipe. Run condensate to an open drain or outdoors.
- The drain line should be insulated where necessary to prevent sweating and damage due to condensate forming on the outside surface of the line.
- Make provisions for disconnecting and cleaning of the primary drain line should it become necessary. Install a 3 in. trap in the primary drain line as close to the unit as possible. Make sure that the top of the trap is below connection to the drain pan to allow complete drainage of pan (See Figure 13).
- The auxiliary drain line should be run to a place where it will be noticeable if it becomes operational. The building occupant should be warned that a problem exists if water should begin running from the auxiliary drain line. An auxiliary drain shut-off switch can be installed in lieu of an auxiliary drain line. The shut-off switch should be wired into the control circuit so the outdoor unit shuts down should the switch detect water.
- Plug the unused drain connection with the plugs provided in the parts bag, using a thin layer of teflon paste, silicone or teflon tape to form a water tight seal.
- Test the condensate drain pan and drain line after installation is complete. Pour water into drain pan, enough to fill drain trap and line. Check to make sure drain pan is draining completely, no leaks are found in drain line fittings, and water is draining from the open end of the primary drain line.

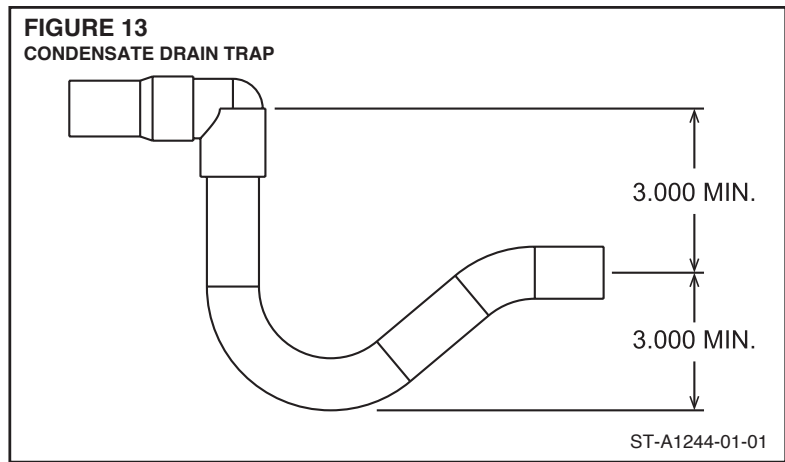

3.11 ECONET™ CONTROL CENTER OR THERMOSTAT

EcoNet™ CONTROL CENTER: All of the EcoNet™ enabled air-handlers covered in this manual are compatible with the communicating EcoNet™ Control Center. The EcoNet™ Control Center provides many benefits over a conventional 24VAC thermostat and is highly recommended to provide the necessary interface between the EcoNet™ enabled outdoor unit and the EcoNet™ enabled air-handler. If a matching EcoNet™ enabled outdoor unit is connected to the EcoNet™ Control Center, the model data from the outdoor unit will be communicated to the EcoNet™ enabled (-)H2V or (-)H2V air-handler which automatically configures the air-handler to deliver the proper air-flow for that system. Other advantages are system status, advanced diagnostics, service tools, and custom adjustments available right at the Control Center as well as 4-wire connectivity, user friendly schedule programming, and internet connectivity using the WiFi module accessory. The EcoNet™ Control Center is required to enable variable speed air-flow in the (-)H2V air-handlers when matched to the variable speed (-)A20 and (-)P20 outdoor units. Air-flow for the (-)H2T air-handler must be configured manually at the blower motor per Section 3.13.2 of this manual, but the EcoNet™ Control Center still provides the advantages of user friendly schedule programming, enhanced diagnostics, 4-wire connectivity, and the ability to connect to the WiFi.

CONVENTIONAL 24VAC THERMOSTAT: All of the air-handlers covered in this manual are capable of being controlled by a conventional 2-stage 24VAC thermostat. For applications involving the variable speed (-)A20 and (-)P20 outdoor units, conventional 24VAC thermostats should only be used in emergency situations where operational problems are encountered using the EcoNet™ Control Center.

LOCATION: A EcoNet™ Control Center should be installed and wired according to the instructions provided with the Control Center and Section 3.12.8 of this manual. A 24VAC thermostat should be installed and wired according the instructions provided with the thermostat and Sections 3.12.9 and 3.12.10 of this manual. The Control Center or thermostat should be mounted 4 – 5 feet above the floor on an inside wall of the living room or hallway that has good air-circulation between all rooms being controlled so an average temperature for all rooms being controlled is being sensed. Movement of air should not be obstructed by furniture, doors, draperies, etc. The Control Center or thermostat should not be mounted where it will be affected by drafts, hot or cold water pipes or air ducts in walls, radiant heat from a fireplace, lamps, TV, or an outside wall.

3.12 ELECTRICAL WIRING

Field wiring must comply with the National Electric Code (C.E.C. in Canada) and any applicable local ordinance.

3.12.1 CONFIGURING UNIT FOR 208 VOLT POWER

The control transformer must be configured in the field to operate on a 208 volt electrical supply to assure adequate control voltage (24+ volts) with the reduced supply voltage. The units are shipped from the factory for 220-240 volt applications. For 208 volt applications, disconnect electrical power to the unit and remove the blower access panel and then the control box cover located on the blower housing. Then remove the insulated cap from the 208 volt transformer terminal and move the BLACK wires that are connected to the 240 volt transformer terminal to the 208 volt transformer terminal. Plug the insulated cap onto the transformer 240V terminal.

3.12.2 GROUNDING

WARNING

The unit must be permanently grounded. Failure to do so can result in electrical shock causing personal injury or death.

- This product must be sufficiently grounded in accordance with National Electrical Code (C.E.C. in Canada) and any applicable local ordinance.
- Grounding may be accomplished by grounding metal conduit when installed in accordance with electrical codes to the unit cabinet.
- Grounding may also be accomplished by attaching ground wire(s) to ground lug(s) provided in the unit wiring compartment.
- Ground lug(s) are located close to wire entrance on left side of unit (upflow). Lug(s) may be moved to marked locations near wire entrance on right side of unit (upflow), if alternate location is more convenient.
- Use of multiple supply circuits require grounding of each circuit to lug(s) provided in unit.

3.12.3 POWER WIRING

It is important that proper electrical power is available for connection to the unit model being installed. See the unit nameplate, wiring diagram and electrical data in the installation instructions.

- If required, install a branch circuit disconnect of adequate size, located within sight of, and readily accessible to the unit.
- **IMPORTANT:** Units with electric heater kits installed may be equipped with one, two, or three 30/60 amp circuit breakers. These breaker(s) protect the internal wiring in the event of a short circuit and serve as a disconnect. Circuit breakers installed within the unit do not provide over-current protection of the supply wiring and therefore may be sized larger than the branch circuit protection.
- Supply circuit power wiring must be 75°C minimum copper conductors only. See Electrical Data in Sections 3.12.5 and 3.12.6 for ampacity, wire size and circuit protector requirement. Supply circuit protective devices may be either fuses or “HACR” type circuit breakers.
- Field power wiring may be connected to either the right, left side or top. Three 7/8”, 1^{3/32}”, 1^{31/32}” dia. concentric knockouts are provided for connection of power wiring to unit.
- Field power wiring is to be connected to the power terminal block in unit control compartment.
- For units equipped with an electric heater kit, field power wiring is to be connected to the heater kit breaker, terminal block, or pullout disconnect terminals and the power wiring pigtail from the heater kit is to be connected to the unit power terminal block in the unit control compartment. Refer to installation instructions provided with the heater kit for additional details.

3.12.4 COPPER WIRE SIZE - AWG. (3% VOLTAGE DROP)

SUPPLY LENGTH	200 [61]	12	10	8	8	8	6	6	6	4	4	3	3	2	2	1	0	00
	150 [46]	12	10	10	10	8	8	6	6	6	4	4	3	3	2	1	0	00
	100 [30]	14	12	10	10	8	8	8	6	6	4	4	3	3	2	1	0	00
	50 [15]	14	12	10	10	8	8	8	6	6	4	4	3	3	2	1	0	00
		15	20	25	30	35	40	45	50	60	70	80	90	100	110	125	150	175
WIRE FEET	SUPPLY CIRCUIT AMPACITY																	
	NOTE: WIRE BASED ON COPPER CONDUCTORS 75°C MINIMUM RATING. FOR MORE THAN 3 CONDUCTORS IN A RACEWAY OR CABLE, SEE N.E.C. FOR DERATING THE AMPACITY OF EACH CONDUCTOR.																	

3.12.5.1 ELECTRICAL DATA – BLOWER MOTOR ONLY – WITHOUT ELECTRIC HEAT: (-)H2T

MODEL (-)H2T	VOLTAGE	PHASE*	HERTZ	HP	RPM	SPEEDS	CIRCUIT AMPS.	MINIMUM CIRCUIT AMPACITY	MAXIMUM OVERCURRENT PROTECTION
2417S	208/240	1	60	1/3	300-1300	2	1.6	2.0	15
2421M		1		1/3		2	1.6	2.0	15
3617S		1		1/2		2	2.8	4.0	15
3621M		1		3/4		2	4.0	5.0	15
4821M		1		3/4		2	4.0	5.0	15
6021S		1		3/4		2	4.6	6.0	15
6024M		1		3/4		2	4.6	6.0	15

*Blower motors are all single phase motors.

3.12.5.2 ELECTRICAL DATA – BLOWER MOTOR ONLY – WITHOUT ELECTRIC HEAT: (-)H2V/(-)H2V

MODEL (-)H2V/(-)H2V	VOLTAGE	PHASE*	HERTZ	HP	RPM	CIRCUIT AMPS.	MINIMUM CIRCUIT AMPACITY	MAXIMUM OVERCURRENT PROTECTION
2417S	208/240	1	60	1/3	300-1100	1.7	3.0	15
2421M		1		1/3		1.7	3.0	15
2421H		1		1/2		3.4	5.0	15
2421U		1		3/4		4.9	7.0	15
3617S		1		1/2		3.4	5.0	15
3621M		1		3/4		4.9	7.0	15
4821M / 6021S		1		3/4		4.9	7.0	15
6024M / 6024M		1		3/4		4.9	7.0	15

*Blower motors are all single phase motors.

3.12.6.1 ELECTRICAL DATA – WITH ELECTRIC HEAT: (-)H2T

Installation of the UL Listed original equipment manufacturer provided heater kits listed in the following table is recommended for all auxiliary heating requirements.

AIR-HANDLER MODEL (-)H2T	HEATER MODEL NO.	HEATER KW 208/240V	PH/HZ	NO. ELEMENTS - KW PER	TYPE SUPPLY CIRCUIT SINGLE CIRCUIT MULTIPLE CIRCUIT	CIRCUIT AMPS.	MOTOR AMPACITY	MINIMUM CIRCUIT AMPACITY	MAXIMUM OVERCURRENT PROTECTION
2417S	RXBH-17?03J	2.25/3.0	1/60	1-3.0	SINGLE	10.8/12.5	1.6	16/18	20/20
2417S 2421M	RXBH-1724?03J	2.25/3.0	1/60	1-3.0	SINGLE	10.8/12.5	1.6	16/18	20/20
	RXBH-1724?05J	3.6/4.8	1/60	1-4.8	SINGLE	17.3/20.0	1.6	24/27	25/30
	RXBH-1724?07J	5.4/7.2	1/60	2-3.6	SINGLE	26.0/30.0	1.6	35/40	35/40
	RXBH-1724?10J	7.2/9.6	1/60	2-4.8	SINGLE	34.6/40.0	1.6	46/52	50/60
	RXBH-1724A13J	9.4/12.5	1/60	3-4.17	SINGLE	45.1/52.1	1.6	59/68	60/70
	RXBH-1724A13J	3.1/4.2	1/60	1-4.17	MULTIPLE CKT 1	15.0/17.4	1.6	21/24	25/25
		6.3/8.3	1/60	2-4.17	MULTIPLE CKT 2	30.1/34.7	0	38/44	40/45
	RXBH-1724A07C	5.4/7.2	3/60	3-2.4	SINGLE	15.0/17.3	1.6	21/24	25/25
	RXBH-1724A10C	7.2/9.6	3/60	3-3.2	SINGLE	20.0/23.1	1.6	27/31	30/35
RXBH-1724A13C	9.4/12.5	3/60	3-4.17	SINGLE	26.1/30.1	1.6	35/40	35/40	
3617S	RXBH-17?03J	2.25/3.0	1/60	1-3.0	SINGLE	10.8/12.5	2.8	17/20	20/20
	RXBH-1724?035	2.25/3.0	1/60	1-3.0	SINGLE	10.8/12.5	2.8	17/20	20/20
	RXBH-1724?05J	3.6/4.8	1/60	1-4.8	SINGLE	17.3/20.0	2.8	26/29	30/30
	RXBH-1724?07J	5.4/7.2	1/60	2-3.6	SINGLE	26.0/30.0	2.8	36/41	40/45
	RXBH-1724?10J	7.2/9.6	1/60	2-4.8	SINGLE	34.6/40.0	2.8	47/54	50/60
	RXBH-1724A13J	9.4/12.5	1/60	3-4.17	SINGLE	45.1/52.1	2.8	60/69	60/70
		3.1/4.2	1/60	1-4.17	MULTIPLE CKT 1	15.0/17.4	2.8	23/26	25/30
	RXBH-1724A15J	6.3/8.3	1/60	2-4.17	MULTIPLE CKT 2	30.1/34.7	0	38/44	40/45
		10.8/14.4	1/60	3-4.8	SINGLE	51.9/60.0	2.8	69/79	70/80
	RXBH-1724A18J	3.6/4.8	1/60	1-4.8	MULTIPLE CKT 1	17.3/20.0	2.8	26/29	30/30
		7.2/9.6	1/60	2-4.8	MULTIPLE CKT 2	34.6/40.0	0	44/50	45/50
	RXBH-1724A18J	12.8/17.0	1/60	3-5.68	SINGLE	61.6/70.8	2.8	81/92	90/100
		4.3/5.7	1/60	1-5.68	MULTIPLE CKT 1	20.5/23.6	2.8	30/33	30/35
	RXBH-1724A18J	8.5/11.3	1/60	2-5.68	MULTIPLE CKT 2	41.1/47.2	0	52/59	60/60
		RXBH-1724A07C	5.4/7.2	3/60	3-2.4	SINGLE	15.0/17.3	2.8	23/26
	RXBH-1724A10C	7.2/9.6	3/60	3-3.2	SINGLE	20.0/23.1	2.8	29/33	30/35
	RXBH-1724A13C	9.4/12.5	3/60	3-4.17	SINGLE	26.1/30.1	2.8	37/42	40/45
	RXBH-1724A15C	10.8/14.4	3/60	3-4.8	SINGLE	30.0/34.6	2.8	41/47	45/50
	RXBH-1724A18C	12.8/17.0	3/60	3-5.68	SINGLE	35.5/41.0	2.8	48/55	50/60
	3621M	RXBH-1724?03J	2.25/3.0	1/60	1-3.0	SINGLE	10.8/12.5	4.0	19/21
RXBH-1724?05J		3.6/4.8	1/60	1-4.8	SINGLE	17.3/20.0	4.0	27/30	30/30
RXBH-1724?07J		5.4/7.2	1/60	2-3.6	SINGLE	26.0/30.0	4.0	38/43	40/45
RXBH-1724?10J		7.2/9.6	1/60	2-4.8	SINGLE	34.6/40.0	4.0	48/55	50/60
RXBH-1724A15J		10.8/14.4	1/60	3-4.8	SINGLE	51.9/60.0	4.0	70/80	70/80
RXBH-1724A15J		3.6/4.8	1/60	1-4.8	MULTIPLE CKT1	17.3/20.0	4.0	27/30	30/30
		7.2/9.6	1/60	2-4.8	MULTIPLE CKT 2	34.6/40.0	0.0	44/50	45/50
RXBH-1724A18J		12.8/17.0	1/60	3-5.68	SINGLE	61.6/70.8	4.0	82/94	90/100
RXBH-1724A18J		4.3/5.7	1/60	1-5.68	MULTIPLE CKT 1	20.5/23.6	4.0	31/35	35/35
		8.5/11.3	1/60	2-5.68	MULTIPLE CKT 2	41.1/47.2	0.0	52/59	60/60
RXBH-1724A07C		5.4/7.2	3/60	3-2.4	SINGLE	15.0/17.3	4.0	24/27	25/30
RXBH-1724A10C		7.2/9.6	3/60	3-3.2	SINGLE	20.0/23.1	4.0	30/34	30/35
RXBH-1724A15C		10.8/14.4	3/60	3-4.8	SINGLE	30.0/34.6	4.0	43/49	45/50
RXBH-1724A18C		12.8/17.0	3/60	3-5.68	SINGLE	35.6/41.0	4.0	50/57	50/60
RXBH-1724B05J		3.6/4.8	1/60	1-4.8	SINGLE	17.3/20.0	4.0	27/30	30/30
RXBH-1724B07J		5.4/7.2	1/60	2-3.6	SINGLE	26.0/30.0	4.0	38/43	40/45
RXBH-1724B10J		7.2/9.6	1/60	2-4.8	SINGLE	34.6/40.0	4.0	48/55	50/60

? Heater Kit Connection Type A=Breaker B=Terminal Block C=Pullout Disconnect

3.12.6.1 ELECTRICAL DATA – WITH ELECTRIC HEAT: (-)H2T - continued

AIR HANDLER MODEL (-)H2T	HEATER MODEL NO.	HEATER KW (208/240V) (480V)	PH/HZ	NO. ELEMENTS - KW PER	TYPE SUPPLY CIRCUIT SINGLE CIRCUIT MULTIPLE CIRCUIT	CIRCUIT AMPS.	MOTOR AMPACITY	MINIMUM CIRCUIT AMPACITY	MAXIMUM OVERCURRENT PROTECTION
4821M	RXBH-1724?05J	3.6/4.8	1/60	1-4.8	SINGLE	17.3/20.0	4.0	27/30	30/30
	RXBH-1724?07J	5.4/7.2	1/60	2-3.6	SINGLE	26.0/30.0	4.0	38/43	40/45
	RXBH-1724?10J	7.2/9.6	1/60	2-4.8	SINGLE	34.6/40.0	4.0	49/55	50/60
	RXBH-1724A15J	10.8/14.4	1/60	3-4.8	SINGLE	51.9/60.0	4.0	70/80	70/80
	RXBH-1724A15J	3.6/4.8	1/60	1-4.8	MULTIPLE CKT 1	17.3/20.0	4.0	27/30	30/30
		7.2/9.6	1/60	2-4.8	MULTIPLE CKT 2	34.6/40.0	0.0	44/50	45/50
	RXBH-1724A18J	12.8/17.0	1/60	3-5.68	SINGLE	61.6/70.8	4.0	82/94	90/100
	RXBJ-1724A18J	4.3/5.7	1/60	1-5.68	MULTIPLE CKT 1	20.5/23.6	4.0	31/35	30/35
		8.5/11.3	1/60	2-5.68	MULTIPLE CKT 2	41.1/47.2	0.0	52/59	60/60
	RXBH-24A20J	14.4/19.2	1/60	4-48	SINGLE	69.2/80	4.0	92/105	100/110
		7.2/9.6	1/60	2-4.8	MULTIPLE CKT 1	34.6/40.0	4.0	49/55	50/60
	RXBH-24A20J	7.2/9.6	1/60	2-4.8	MULTIPLE CKT 2	34.6/40.0	0.0	44/50	45/50
	RXBH-24A25J	18.0/24.0	1/60	6-4.0	SINGLE	86.4/99.9	4.0	113/130	125/150
	RXBH-24A25J	6.0/8.0	1/60	2-4.0	MULTIPLE CKT 1	28.8/33.3	4.0	41/47	45/50
		6.0/8.0	1/60	2-4.0	MULTIPLE CKT 2	28.8/33.3	0.0	36/42	40/45
		6.0/8.0	1/60	2-4.0	MULTIPLE CKT 3	28.8/33.3	0.0	36/42	40/45
	RXBH-1724A07C	5.4/7.2	3/60	3-2.4	SINGLE	15.0/17.3	4.0	24/27	25/30
	RXBH-1724A10C	7.2/9.6	3/60	3-3.2	SINGLE	20.0/23.1	4.0	30/34	30/35
	RXBH-1724A15C	10.8/14.4	3/60	3-4.8	SINGLE	30.0/34.6	4.0	43/49	45/50
	RXBH-1724A18C	12.8/17.0	3/60	3-5.68	SINGLE	35.6/41.0	4.0	50/57	50/60
	RXBH-24A20C*	14.4/19.2	3/60	3-3.2	SINGLE	40.0/46.2	4.0	55/63	60/70
	RXBH-24A20C	7.2/9.6	3/60	3-3.2	MULTIPLE CKT 1	20.0/23.1	4.0	30/34	30/35
		7.2/9.6	3/60	3-3.2	MULTIPLE CKT 2	20.0/23.1	0.0	25/29	25/30
	RXBH-24A25C*	18.0/24.0	3/60	6-4.0	SINGLE	50.0/57.8	4.0	68/77	70/80
	RXBH-24A25C	9.0/12.0	3/60	3-4.0	MULTIPLE CKT 1	25.0/28.9	4.0	37/42	40/45
		9.0/12.0	3/60	3-4.0	MULTIPLE CKT 2	25.0/28.9	0.0	32/37	35/40

? Heater Kit Connection Type A = Breaker B = Terminal Block C = Pullout Disconnect

3.12.6.1 ELECTRICAL DATA – WITH ELECTRIC HEAT: (-)H2T - continued

AIR-HANDLER MODEL (-)H2T	HEATER MODEL NO.	HEATER KW 208/240V	PH/HZ	NO. ELEMENTS - KW PER	TYPE SUPPLY CIRCUIT SINGLE CIRCUIT MULTIPLE CIRCUIT	CIRCUIT AMPS.	MOTOR AMPACITY	MINIMUM CIRCUIT AMPACITY	MAXIMUM OVERCURRENT PROTECTION
6021S 6024M	RXBH-1724?05J	3.6/4.8	1/60	1-4.8	SINGLE	17.3/20.0	4.6	28/31	30/35
	RXBH-1724?07J	5.4/7.2	1/60	2-3.6	SINGLE	26.0/30.0	4.6	39/44	40/45
	RXBH-1724?10J	7.2/9.6	1/60	2-4.8	SINGLE	34.6/40.0	4.6	49/56	50/60
	RXBH-1724A15J	10.8/14.4	1/60	3-4.8	SINGLE	51.9/60.0	4.6	71/81	80/90
	RXBH-1724A15J	3.6/4.8	1/60	1-4.8	MULTIPLE CKT 1	17.3/20.0	4.6	28/31	30/35
		7.2/9.6	1/60	2-4.8	MULTIPLE CKT 2	34.6/40.0	0	44/50	45/50
	RXBH-1724A18J	12.8/17	1/60	3-5.68	SINGLE	61.6/70.8	4.6	83/95	90/100
	RXBH-1724A18J	4.3/5.7	1/60	1-5.68	MULTIPLE CKT 1	20.5/23.6	4.6	31/35	31/35
		4.3/5.7	1/60	2-4.26	MULTIPLE CKT 2	41.1/47.2	0	52/59	60/60
	RXBH-24A20J	14.4/19.2	1/60	4-4.8	SINGLE	69.2/80	4.6	93/106	100/110
	RXBH-24A20J	7.2/9.6	1/60	2-4.8	MULTIPLE CKT 1	34.6/40.0	4.6	49/56	50/60
		7.2/9.6	1/60	2-4.8	MULTIPLE CKT 2	34.6/40.0	0	44/50	45/50
	RXBH-24A25J	18.0/24.0	1/60	6-4.0	SINGLE	86.4/99.9	4.6	114/131	125/150
	RXBH-24A25J	6.0/8.0	1/60	2-4.0	MULTIPLE CKT 1	28.8/33.3	4.6	42/48	45/50
		6.0/8.0	1/60	2-4.0	MULTIPLE CKT 2	28.8/33.3	0	36/42	40/45
		6.0/8.0	1/60	2-4.0	MULTIPLE CKT 3	28.8/33.3	0	36/42	40/45
	RXBH-24A30J (6024S only) (1800 CFM only)	21.6/28.8	1/60	6-4.8	SINGLE	103.8/120.0	4.6	136/156	150/175
	RXBH-24A30J (6024S only) (1800 CFM only)	7.2/9.6	1/60	2-4.8	MULTIPLE CKT 1	34.6/40.0	4.6	49/56	50/60
		7.2/9.6	1/60	2-4.8	MULTIPLE CKT 2	34.6/40.0	0	44/50	45/50
		7.2/9.6	1/60	2-4.8	MULTIPLE CKT 3	34.6/40.0	0	44/50	45/50
	RXBH-1724A07C	5.4/7.2	3/60	3-2.4	SINGLE	15.0/17.3	4.6	25/28	25/30
	RXBH-1724A10C	7.2/9.6	3/60	3-3.2	SINGLE	20.0/23.1	4.6	31/35	35/35
	RXBH-1724A15C	10.8/14.4	3/60	3-4.8	SINGLE	30.0/34.6	4.6	44/49	45/50
	RXBH-1724A18C	12.8/17.0	3/60	3-5.68	SINGLE	35.6/41.0	4.6	51/57	50/60
	RXBH-24A20C*	14.4/19.2	3/60	3-3.2	SINGLE	40.0/46.2	4.6	56/64	60/70
		7.2/9.6	3/60	3-3.2	MULTIPLE CKT 1	20.0/23.1	4.6	31/35	35/35
		7.2/9.6	3/60	3-3.2	MULTIPLE CKT 2	20.0/23.1	0	25/29	25/30
	RXBH-24A25C*	18.0/24.0	3/60	6-4.0	SINGLE	50.0/57.8	4.6	69/78	70/80
	RXBH-24A25C	9.0/12.0	3/60	3-4.0	MULTIPLE CKT 1	25.0/28.9	4.6	37/42	40/45
		9.0/12.0	3/60	3-4.0	MULTIPLE CKT 2	25.0/28.9	0	32/37	35/40
	RXBH-24A30C* (1800 CFM only)	21.6/28.8	3/60	6-4.8	SINGLE	60.0/69.4	4.6	81/93	90/100
	RXBH-24A30C (6024S only) (1800 CFM only)	10.8/14.4	3/60	3-4.8	MULTIPLE CKT 1	30.0/34.7	4.6	44/50	45/50
10.8/14.4		3/60	3-4.8	MULTIPLE CKT 2	30.0/34.7	0	38/44	40/45	

? Heater Kit Connection Type A = Breaker B = Terminal Block C = Pullout Disconnect

NOTES:

- * Values only. No single point kit available.
- Electric heater BTUH - (heater watts + motor watts) × 3.414 (see airflow table for motor watts.)
- Supply circuit protective devices may be fuses or “HACR” type circuit breakers.
- Motor load is included in single circuit and multiple circuit 1.
- Heater loads are balanced on 3 phase heater kits with 3 or 6 heating elements only.
- J Voltage (230V) single phase air handler is designed to be used with single or three phase 230 volt electric heaters. To connect 3-phase power to the air handler terminal block, bring only two leads to the terminal block, cap, insulate, and fully secure the third lead.
- If the kit is listed under both single and multiple circuits, the heater kit is shipped from factory as multiple circuits. For single phase applications, Jumper bar kit RXBJ-A21 and RXBJ-A31 can be used to convert multiple circuits to a single supply circuit. See Section 6.2 for details.
- The airflow for continuous fan is set 50% of the cooling airflow.

3.12.6.2 ELECTRICAL DATA – WITH ELECTRIC HEAT (-)H2V/(-)HMV

Installation of the UL Listed original equipment manufacturer provided heater kits listed in the following table is recommended for all auxiliary heating requirements.

MODEL SIZE (-)H2V/(-)HMV	MANUFACTURER MODEL NUMBER	HEATER kW (208/240)	PH/HZ	NO. ELEMENTS - KW PER	TYPE SUPPLY CIRCUIT	CIRCUIT AMPS	MOTOR AMPACITY	MINIMUM CIRCUIT AMPACITY	MAXIMUM OVERCURRENT PROTECTION
2417S	RXBH-17?03J	2.25/3.0	1/60	1-3.0	SINGLE	10.8/12.5	2.9	16/18	20/20
2417S 2421M	RXBH-1724?03J	2.25/3.0	1/60	1-3.0	SINGLE	10.8/12.5	2.9	16/18	20/20
	RXBH-1724?05J	3.6/4.8	1/60	1-4.8	SINGLE	17.3/20.0	2.9	24/28	25/30
	RXBH-1724?07J	5.4/7.2	1/60	2-3.6	SINGLE	26.0/30.0	2.9	35/40	35/40
2421H	RXBH-1724?10J	7.2/9.6	1/60	2-4.8	SINGLE	34.6/40.0	2.9	46/53	50/60
	RXBH-1724?03J	2.25/3.0	1/60	1-3.0	SINGLE	10.8/12.5	3.4	18/20	20/20
	RXBH-1724?05J	3.6/4.8	1/60	1-4.8	SINGLE	17.3/20.0	3.4	26/28	30/30
	RXBH-1724?07J	5.4/7.2	1/60	2-3.6	SINGLE	26.0/30.0	3.4	37/42	40/45
2421U	RXBH-1724?10J	7.2/9.6	1/60	2-4.8	SINGLE	34.6/40.0	3.4	48/55	50/60
	RXBH-1724?03J	2.25/3.0	1/60	1-3.0	SINGLE	10.8/12.5	4.9	19/21	20/25
	RXBH-1724?05J	3.6/4.8	1/60	1-4.8	SINGLE	17.3/20.0	4.9	28/32	30/35
	RXBH-1724?07J	5.4/7.2	1/60	2-3.6	SINGLE	26.0/30.0	4.9	39/44	40/45
3617S	RXBH-1724?10J	7.2/9.6	1/60	2-4.8	SINGLE	34.6/40.0	4.9	50/57	50/60
	RXBH-17?03J	2.25/3.0	1/60	1-3.0	SINGLE	10.8/12.5	3.4	18/20	20/20
	RXBH-1724?03J	2.25/3.0	1/60	1-3.0	SINGLE	10.8/12.5	3.4	18/20	20/20
	RXBH-1724?05J	3.6/4.8	1/60	1-4.8	SINGLE	17.3/20.0	3.4	26/29	30/30
	RXBH-1724?07J	5.4/7.2	1/60	2-3.6	SINGLE	26.0/30.0	3.4	37/42	40/45
	RXBH-1724?10J	7.2/9.6	1/60	2-4.8	SINGLE	34.6/40.0	3.4	48/54	50/60
	RXBH-1724A15J	10.8/14.4	1/60	3-4.8	SINGLE	51.9/60.0	3.4	70/80	70/80
		3.6/4.8	1/60	1-4.8	MULTIPLE CKT 1	17.3/20.0	3.4	26/30	30/30
	RXBH-1724A18J	7.2/9.6	1/60	2-4.8	MULTIPLE CKT 2	34.6/40.0	0	44/50	45/50
		12.8/17.0	1/60	3-5.68	SINGLE	61.6/70.8	3.4	82/93	90/100
4.3/5.7		1/60	1-5.68	MULTIPLE CKT 1	20.5/23.6	3.4	30/34	30/35	
8.5/11.3		1/60	2-5.68	MULTIPLE CKT 2	41.1/47.2	0	52/59	60/60	

? Heater Kit Connection Type A = Breaker B = Terminal Block C = Pullout Disconnect

3.12.6.2 ELECTRICAL DATA – WITH ELECTRIC HEAT: (-)H2V/(-)H MV - continued

MODEL SIZE (-)H2V/ (-)H MV	MANUFACTURER MODEL NUMBER	HEATER kW (208/240)	PH/HZ	NO. ELEMENTS - KW PER	TYPE SUPPLY CIRCUIT	CIRCUIT AMPS	MOTOR AMPACITY	MINIMUM CIRCUIT AMPACITY	MAXIMUM OVERCURRENT PROTECTION
3621M 4821M 6021S	RXBH-1724?05J	3.6/4.8	1/60	1-4.8	SINGLE	17.3/20.0	4.9	28/32	30/35
	RXBH-1724?07J	5.4/7.2	1/60	2-3.6	SINGLE	26.0/30.0	4.9	39/44	40/45
	RXBH-1724?10J	7.2/9.6	1/60	2-4.8	SINGLE	34.6/40.0	4.9	50/57	50/60
	RXBH-1724A15J	10.8/14.4	1/60	3-4.8	SINGLE	51.9/60.0	4.9	72/82	80/90
		3.6/4.8	1/60	1-4.8	MULTIPLE CKT 1	17.3/20.0	4.9	28/32	30/35
		7.2/9.6	1/60	2-4.8	MULTIPLE CKT 2	34.6/40.0	4.9	44/50	45/50
	RXBH-1724A18J	12.8/17.0	1/60	3-5.68	SINGLE	61.6/70.8	4.9	84/95	90/100
		4.3/5.7	1/60	1-5.68	MULTIPLE CKT 1	20.5/23.6	4.9	32/36	35/40
		8.5/11.3	1/60	2-5.68	MULTIPLE CKT 2	41.1/47.2	0.0	52/59	60/60
	RXBH-24A20J 4821/6021 only	14.4/19.2	1/60	4-4.8	SINGLE	69.2/80	4.9	93/107	100/110
		7.2/9.6	1/60	2-4.8	MULTIPLE CKT 1	34.6/40.0	4.9	50/57	50/60
		7.2/9.6	1/60	2-4.8	MULTIPLE CKT 2	34.6/40.0	0.0	44/50	45/50
	RXBH-24A25J 4821/6021 only	18.0/24.0	1/60	6-4.0	SINGLE	86.4/99.9	4.9	115/132	125/150
		6.0/8.0	1/60	2-4.0	MULTIPLE CKT 1	28.8/33.3	4.0	43/48	45/50
		6.0/8.0	1/60	2-4.0	MULTIPLE CKT 2	28.8/33.3	0.0	37/42	40/45
		6.0/8.0	1/60	2-4.0	MULTIPLE CKT 3	28.8/33.3	0.0	37/42	40/45
6024M	RXBH-1724?05J	3.6/4.8	1/60	1-4.8	SINGLE	17.3/20.0	4.9	28/32	30/35
	RXBH-1724?07J	5.4/7.3	1/60	2-3.6	SINGLE	26.0/30.0	4.9	39/44	40/45
	RXBH-1724?10J	5.4/7.2	1/60	2-4.8	SINGLE	26.0/30.0	4.9	39/44	40/45
	RXBH-1724A15J	10.8/14.4	1/60	3-4.8	SINGLE	51.9/60.0	4.9	72/82	80/90
		3.6/4.8	1/60	1-4.8	MULTI. CKT 1	17.3/20.0	4.9	28/32	30/35
		7.2/9.6	1/60	2-4.8	MULTI. CKT	34.6/40.0	0	44/50	45/50
	RXBH-1724A18J	12.8/17	1/60	3-5.68	SINGLE	61.6/70.8	4.9	84/95	90/100
		4.3/5.7	1/60	1-5.68	MULTI. CKT 1	20.5/23.6	4.9	35/40	32/36
		8.5/11.3	1/60	2-5.68	MULTI. CKT 2	41.1/47.2	0	60/60	52/59
	RXBH-24A20J	14.4/19.2	1/60	4-4.8	SINGLE	69.2/80.0	4.4	93/107	100/110
		7.2/9.6	1/60	2-4.8	MULTI. CKT 1	34.6/40.0	4.4	50/57	50/60
		7.2/9.6	1/60	2-4.8	MULTI. CKT 2	34.6/40.0	0	44/50	45/50
	RXBH-24A25J	18.0/24.0	1/60	6-4.0	SINGLE	87.0/99.9	4.9	115/132	125/150
		6.0/8.0	1/60	2-4.0	MULTI. CKT 1	29.0/33.3	4.9	43/48	45/50
		6.0/8.0	1/60	2-4.0	MULTI. CKT 2	29.0/33.3	0	37/42	40/45
		6.0/8.0	1/60	2-4.0	MULTI. CKT 3	29.0/33.3	0	37/42	40/45
	RXBH-24A30J (1800 CFM only)	21.6/28.8	1/60	4-8.6	SINGLE	103.8/120.0	4.9	150/175	136/156
		7.2/9.6	1/60	2-4.8	MULTI. CKT 1	34.6/40.0	4.9	50/60	49/56
		2-4.8	1/60	2-4.8	MULTI. CKT 2	34.6/40.0	0	45/50	44/50
		7.2/9.6	1/60	2-4.8	MULTI. CKT 3	34.6/40.0	0	45/50	44/50

? Heater Kit Connection Type A = Breaker B = Terminal Block C = Pullout Disconnect

NOTES:

- * Values only. No single point kit available.
- Electric heater BTUH - (heater watts + motor watts) × 3.414 (see airflow table for motor watts.)
- Supply circuit protective devices may be fuses or “HACR” type circuit breakers.
- Motor load is included in single circuit and multiple circuit 1.
- Heater loads are balanced on 3 phase heater kits with 3 or 6 heating elements only.
- J Voltage (230V) single phase air handler is designed to be used with single or three phase 230 volt electric heaters. To connect 3-phase power to the air handler terminal block, bring only two leads to the terminal block, cap, insulate, and fully secure the third lead.
- If the kit is listed under both single and multiple circuits, the heater kit is shipped from factory as multiple circuits. For single phase applications, Jumper bar kit RXBJ-A21 and RXBJ-A31 can be used to convert multiple circuits to a single supply circuit. See Section 6.2 for details.
- The airflow for continuous fan is set 50% of the cooling airflow.

3.12.7 ELECTRIC HEATER KIT SUPPLEMENTAL INFORMATION

MFD: MO./YEAR 01/2006 AIR CONDITIONING DIVISION MADE IN THE U.S.A. FAIT DANS L'USA

MODEL/MODELE # 208/240 PH/HZ 1/60 SERIAL/EN SERIE # W0118 38751

VOLTS 208/240 MOTOR HP./F.L.A. 1/2 4.1 MOTEUR PSC/F.L.A.

ATTENTION: MARK HEATER INSTALLED/L'APPAREIL DE CHAUFFAGE DE MARQUE A INSTALLER

HEATER MODEL/MODELE D'APPAREIL DE CHAUFFAGE	TYPE SUPPLY CIRCUIT/FABRIQUE LE CIRCUIT DE PROVISION	VOLTAGE/TENSION	PHASE	KW	HEATER AMPS/AMPLIS D'APPAREIL DE CHAUFFAGE	MOTOR AMPS/LES AMPLIS MOTEURS	MAXIMUM OVERCURRENT PROTECTION LA PROTECTION MAXIMUM DE L'OVERCURRENT	MINIMUM BRANCH CIRCUIT AMPACITY/AMPCAPTE MINIMUM DE CIRCUIT DE BRANCHE
NO HEAT				0.0		4.1	15	5.2
RXBH-24A05J	SINGLE	208/240	1/60	3.6/4.8	17.3/20.0	6.0	30/35	30/33
RXBH-24A07J	SINGLE	208/240	1/60	5.4/7.2	26.0/30.0	6.0	40/45	40/45
RXBH-24A10J	SINGLE	208/240	1/60	7.2/9.6	34.6/40.0	6.0	60/60	51/58
RXBH-24A15J	SINGLE	208/240	1/60	10.8/14.4	51.9/60.0	6.0	80/90	73/83
RXBH-24A15J	MULTI CKT 1	208/240	1/60	3.6/4.8	17.3/20.0	6.0	30/35	30/33
RXBH-24A15J	MULTI CKT 2	208/240	1/60	7.2/9.6	34.6/40.0	0.0	45/50	44/50
RXBH-24A18J	SINGLE	208/240	1/60	12.8/17.0	61.2/70.8	6.0	90/100	84/96
RXBH-24A18J	MULTI CKT 1	208/240	1/60	6.4/8.5	30.8/35.4	6.0	50/60	46/52
RXBH-24A18J	MULTI CKT 2	208/240	1/60	6.4/8.5	30.8/35.4	0.0	40/45	39/45
RXBH-24A20J	SINGLE	208/240	1/60	14.4/19.2	69.2/80.0	6.0	100/110	94/108
RXBH-24A20J	MULTI CKT 1	208/240	1/60	7.2/9.6	34.6/40.0	6.0	60/60	51/58
RXBH-24A20J	MULTI CKT 2	208/240	1/60	7.2/9.6	34.6/40.0	0.0	45/50	44/50
RXBH-24A07C	SINGLE	208/240	3/60	5.4/7.2	15.0/17.3	6.0	30/30	27/30
RXBH-24A10C	SINGLE	208/240	3/60	7.2/9.6	20.0/23.1	6.0	35/40	33/37
RXBH-24A15C	SINGLE	208/240	3/60	10.8/14.4	30.0/34.6	6.0	45/60	45/51
RXBH-24A18C	SINGLE	208/240	3/60	12.4/17.0	35.6/41.0	6.0	60/60	52/59
RXBH-24A18C	MULTI CKT 1	208/240	3/60	6.4/8.5	17.8/20.5	6.0	30/35	30/34
RXBH-24A18C	MULTI CKT 2	208/240	3/60	6.4/8.5	17.8/20.5	0.0	25/30	23/26
RXBH-24A20C	SINGLE	208/240	3/60	14.2/19.2	40.0/46.2	6.0	60/70	58/66
RXBH-24A20C	MULTI CKT 1	208/240	3/60	7.2/9.6	20.0/23.1	6.0	35/40	33/37
RXBH-24A20C	MULTI CKT 2	208/240	3/60	7.2/9.6	20.0/23.1	0.0	25/30	25/29

S = SINGLE CIRCUIT/CIRCUIT SIMPLE M = MULTIPLE CIRCUIT/CIRCUIT MULTIPLE

INDOOR BLOWER MOTOR LOAD INCLUDED IN CIRCUIT # 1 OR TOTAL SUPPLY WIRE MUST BE RATED AT 75°C MINIMUM COPPER CONDUCTORS ONLY. TEST EXTERNAL STATIC RANGE: 1 TO 5 IN. W.C. (HEAT PUMP & ELECTRIC HEAT).

UNITS WITH ELECTRIC HEATERS: CLEARANCE TO COMBUSTIBLE MATERIAL TO BE 0 IN. TO UNIT CASING AND 0 IN. TO PLENUM AND DUCT FOR FIRST 36 IN. MODELS HAVE INTEGRAL CIRCUIT BREAKERS WHICH PROVIDE SUPPLEMENTARY OVERCURRENT PROTECTION AND SERVE AS A MAINTENANCE "DISCONNECT". SUPPLY CIRCUIT NOT TO EXCEED 120 VOLTS TO GROUND ON SINGLE PHASE UNITS. REPLACE LINE SIDE BREAKER COVER(S) AFTER MAKING WIRING CONNECTIONS TO BREAKER(S). IF BLOWER-CONTROL ASSEMBLY REQUIRES REMOVAL, SEE "WARNING HAZARDOUS VOLTAGE".

CHARGEMENT DU MOTEUR SOUFFLEUR INTERNE INCLUS DANS LE CIRCUIT # 1 OU CAPACITÉ DU CÂBLAGE D'ALIMENTATION TOTAL DOIT ÊTRE DE 75C DU MINIMUM DE CONDUCTEURS DE CUIVRE SEULEMENT. TESTER L'INTERVALLE STATIQUE EXTERNE: 1 À 5 PO W.C (THERMOPOMPE ET CHAUFFAGE ÉLECTRIQUE)

UNITÉS AVEC CHAUFFAGES ÉLECTRIQUES: LE DÉGAGEMENT AUX MATIÈRES COMBUSTIBLES DOIT ÊTRE DE 0 po AU BOITIER DE L'UNITÉ ET DE 0 po AU PLÉNUM ET CONDUIT POUR LES 36 PREMIERS po. LES MODÈLES DISPOSENT DE DISJONCTEURS INTÉGRÉS QUI FOURNISSENT UNE PROTECTION SUPPLÉMENTAIRE DE SURINTENSITÉ DE COURANT ET SERVENT DE « SECTIONNEUR » D'ENTRETIEN. LE CIRCUIT D'ALIMENTATION NE DOIT PAS DÉPASSER 120 VOLTS JUSQU'AU SOL SUR DES UNITÉS MONOPHASÉES. REMPLACER LE(S) COUVERCLE(S) DU DISJONCTEUR DU CÔTÉ SECTEUR APRÈS AVOIR EFFECTUÉ LA CONNEXION DES CÂBLAGES AU(X) DISJONCTEUR(S). SI L'ASSEMBLAGE DE CONTRÔLE DU VENTILATEUR A BESOIN D'ÊTRE DÉASSEMBLÉ, CONSULTER "AVERTISSEMENT DE TENSION DANGEREUSE"

If a heater kit is listed both Single and Multi-circuit, the kit is shipped as a Multi-circuit and will require a single point kit.

Contractor should "mark or check" the left column for the kit installed.

These are the required maximum and minimum circuit breaker sizes for overcurrent protection and should not be confused with the size of the breakers installed in the heater kit.

Only listed kits can be applied

Heater Kit Supplemental Information: What allows the manufacturer to use standard Circuit Breakers up to 60 amps inside the air handler, when using an approved Heater Kit?

National Electric Code (Section 424-22b) and UL standards allow subdividing heating element circuits, of less than 48 amps, using breakers of not more than 60 amps. Additionally per NEC 424-3b, a rating not less than 125 percent of the load and NEC 424-22c, which describes the supplementary overcurrent protection required to be factory-installed within, or on the heater. The breakers in the heater kit are not, and have never been intended to protect power wiring leading to the air handler unit. The breakers in the heating kit are for short circuit protection and to provide a disconnect. All internal unit wiring, where the breakers apply, has been UL approved for short circuit protection.

Ampacity, (not breaker size), determines supply circuit wire size. The ampacity listed on the unit rating plate and the Maximum and Minimum circuit breaker size (noted above) or in the units specification sheet or installation instructions provides the information to properly select wire and circuit breaker/protector size. The National Electric Code (NEC) specifies that the supply or branch circuit must be protected at the source.

3.12.8 ECONET™ COMMUNICATIONS CONTROL WIRING

The EcoNet™ (-)H2T/(-)H2V/(-)HMV series of air handlers are designed to operate with conventional 24VAC controls or with an EcoNet™ communicating system.

For the EcoNet™ communicating system, you must have:

- Air handler equipped with a **EcoNet™ Control**
- Condensing unit or heat pump equipped with a **EcoNet™ Control**.
- An EcoNet™ Control Center

If your equipment does not meet this criteria, you must wire it using conventional 24VAC thermostat control wiring. Reference Section 3.12.9.

EcoNet™ requires four (4) control wires for unit operation:

- R – 24VAC
- C – 24VAC common
- E1 – Data wire 1
- E2 – Data wire 2

Wiring sizing for **EcoNet™ communication** is identical to systems using low voltage 24V wires.

Note: The **EcoNet™ system** requires a minimum 18 AWG.

IMPORTANT: Class 2 low voltage control wire should not be run in conduit with power wiring and must be separated from power wiring, unless Class 1 wire of proper voltage rating is used.

- The four 18AWG low voltage control wires must be installed from the thermostat to the indoor unit and from indoor unit to the outdoor unit. The wire length between the thermostat and indoor unit should not be greater than 100 feet. The wire length between the indoor unit and outdoor unit should not be greater than 125 feet.
- Low voltage control connections are made by extending wires from top of air handler using wire nuts.
- Refer to Figure 14 below for control wiring connections.
- Do not leave excess field control wiring inside unit, pull excess control wire to outside of unit and provide strain relief for field wiring on inside of cabinet at point wiring penetrates cabinet.
- Make sure, after installation, separation of control wiring and power wiring has been maintained.

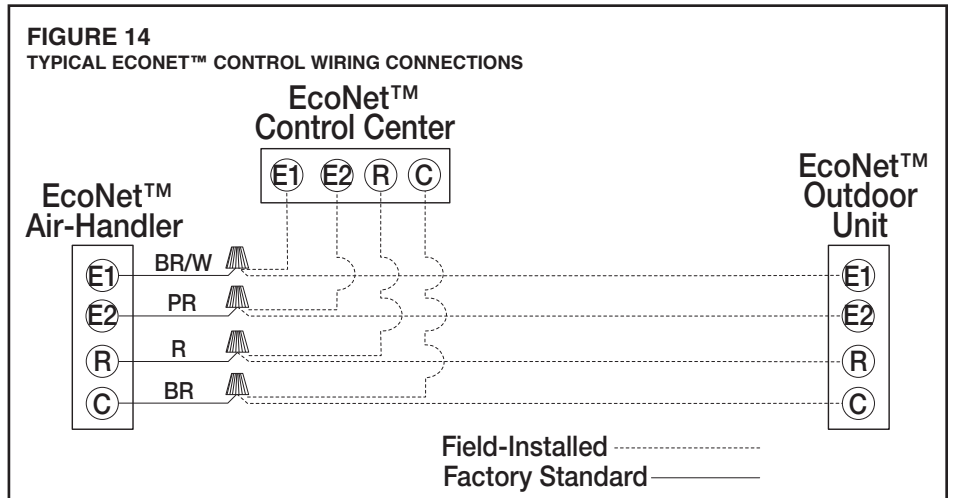

3.12.9 AUXILIARY SWITCH INPUTS

(ECONET™ COMMUNICATING SYSTEMS ONLY – SEE FIGURE 15)

Three pigtail control wires (AUXC – orange/blue, AUX1 – orange, AUX2 – gray) are provided as inputs for field installation of up to two auxiliary switches. The auxiliary inputs are for traditional drain pan switches, drain overflow switches, smoke detectors, freeze switches, etc. The auxiliary switch inputs will only work when the air-handler is wired for EcoNet™ communication. Using these inputs for communicating systems is superior to wiring the switches in series with the “R” circuit since the EcoNet™ Control Center provides multiple response options than simply shutting down the entire system including the Control Center. Using the auxiliary inputs will also allow the Control Center to display the fault on the screen and can be configured to sound an audible alarm. The auxiliary inputs must be configured at the EcoNet™ Control Center as either “normally-open” or “normally closed” contacts. How the system responds to the contacts opening or closing can be configured at the EcoNet™ Control Center.

A resistance of greater than 1000 ohms to common will be recognized as an open switch and a resistance of less than 100 ohms will be recognized as a closed switch.

FIGURE 15**WIRING OF AUXILIARY SWITCH INPUTS (USE WITH COMMUNICATING SYSTEMS ONLY)****WIRING DIAGRAM - OPTIONAL AUXILIARY INPUTS**

NOTE: AUXILIARY INPUTS ARE ONLY MONITORED IN COMMUNICATING MODE.

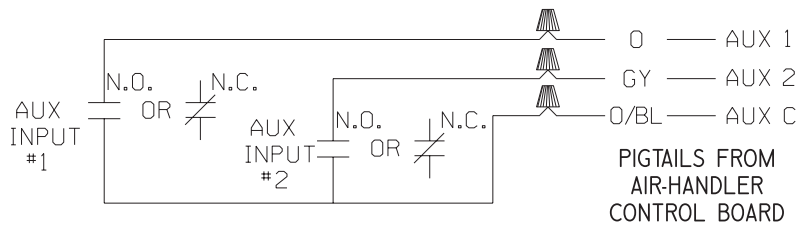

NOTE: EITHER A NORMALLY-OPENED (N.O.) OR NORMALLY-CLOSED (N.C.) ACCESSORY CAN BE ATTACHED TO AUXILIARY INPUTS 1 AND/OR 2. SELECT CONFIGURATION (N.O. OR N.C.) AT THE ECONET™ CONTROL CENTER.

3.12.10 CONVENTIONAL 24VAC THERMOSTAT CONTROL WIRING

The (-)H2T/(-)H2V/(-)HMV-series air-handlers and (-)A17/(-)P17/(-)P20**A/(-)A20-series of outdoor units allow the installer to use conventional 24VAC control wiring and a conventional 2-stage thermostat for unit operation. (-)P20**B-series heat pumps operate in single-stage mode at nominal capacity when being controlled by a conventional 24VAC thermostat which requires the Y1 and Y2 thermostat pigtails on the air-handler to be wired together to assure full air-flow.

IMPORTANT: The preferred method of unit installation and operation is by the EcoNet™ Communicating System, which allows access to the fault history of the system. This diagnostic information is not available when the (-)A17/(-)P17/(-)P20/(-)A20 unit is using a conventional thermostat. Reference section 3.12.8, EcoNet™ Control Wiring.

Thermostat control wiring requires a minimum of seven (7) wires for proper unit operation:

- R – 24VAC
 - C – 24VAC common
 - G – Constant Fan
 - W1 – First stage electric heat
 - W2 – Second stage electric heat
 - Y1 – First stage operation
 - Y2 – Second stage operation
- NOTE: Y1 and Y2 to be wired together for (-)P20**B

Optional wiring:

- ODD – On demand humidification

NOTE: W1 and W2 may be jumpered together to energize all the electric heat when a call for electric heat is received if warmer supply air is desired.

NOTE: When using 24VAC thermostat control wiring, the serial communicating control will ignore any inputs to Data wire 1 and Data wire 2.

IMPORTANT: Class 2 low voltage control wire should not be run in conduit with power wiring and must be separated from power wiring, unless Class 1 wire of proper voltage rating is used.

Low voltage control wiring should be 18 AWG color-coded (105°C minimum). For lengths longer than 100 ft., 16 AWG wire should be used.

Low voltage control connections are made at the thermostat pigtails extending wires from top of air handler using wire nuts. The thermostat pigtails can be rerouted through 3/4" diameter knock-outs located on each side of the air-handler cabinet for applications where the top exit is not suitable.

See wiring diagrams attached to indoor and outdoor sections to be connected.

Do not leave excess field control wiring inside unit, pull excess control wire to outside of unit and provide strain relief for field wiring on inside of cabinet where wiring penetrates cabinet.

Make sure, after installation, separation of control wiring and power wiring has been maintained.

See Section 3.12.1 for 208 volt applications.

3.12.11 CONVENTIONAL 24VAC THERMOSTAT CONTROL WIRING CONNECTION DIAGRAMS

The low voltage application diagrams shown in Figures 16-29 below are specific to (-)A17, (-)A20, (-)P17, and (-)P20 series outdoor units. If connecting this air-handler to other models, there may be differences in how the outdoor units are to be connected and will require referencing the outdoor unit manufacturer's installation instructions for connecting control wiring to that specific model.

WIRE COLOR CODE			
BK – BLACK	G – GREEN	PR – PURPLE	Y – YELLOW
BR – BROWN	GY – GRAY	R – RED	
BL – BLUE	O – ORANGE	W – WHITE	

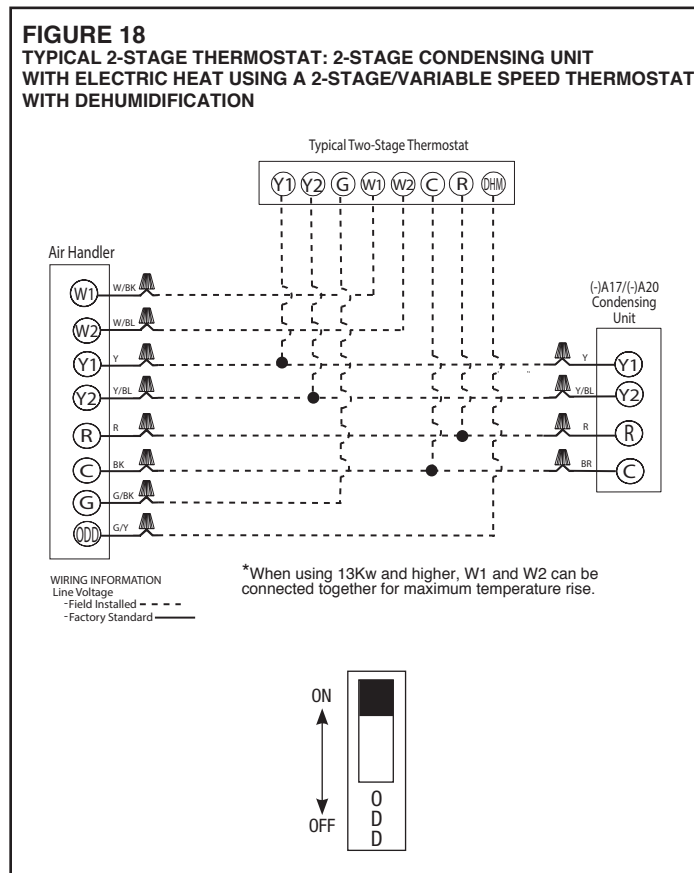
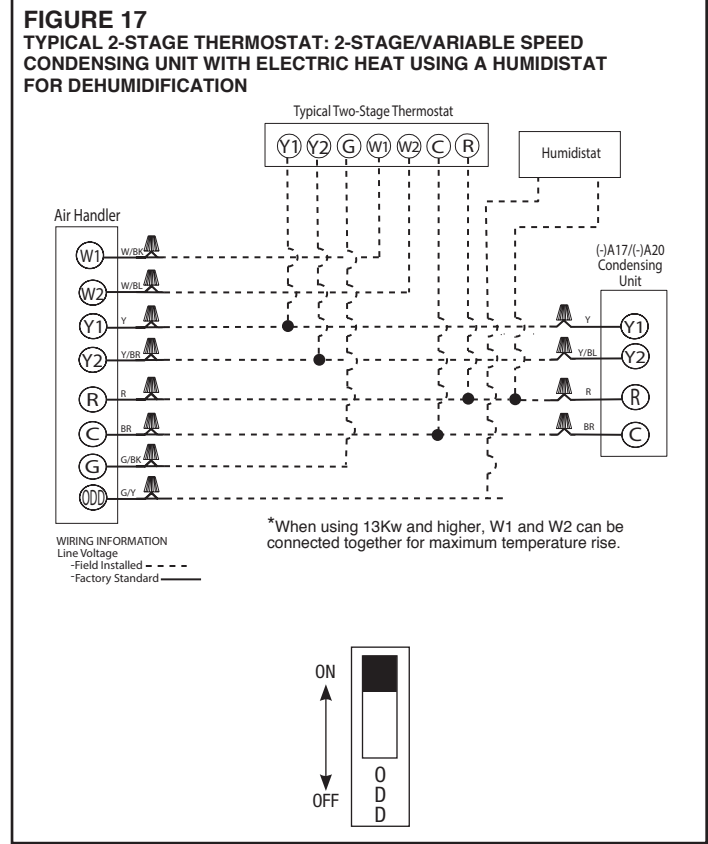
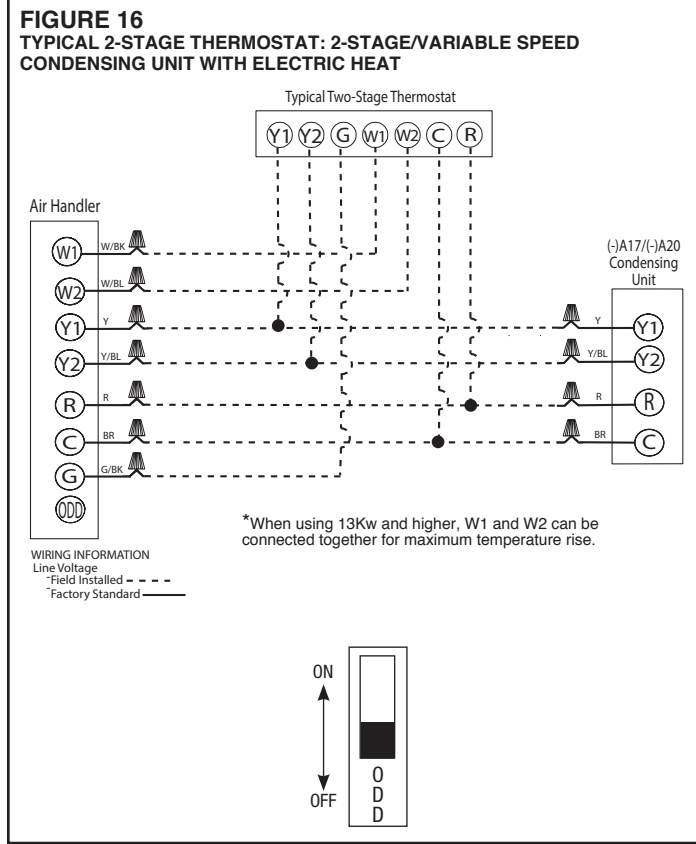

3.12.11 CONVENTIONAL 24VAC THERMOSTAT CONTROL WIRING CONNECTION DIAGRAMS – continued

WIRE COLOR CODE			
BK – BLACK	G – GREEN	PR – PURPLE	Y – YELLOW
BR – BROWN	GY – GRAY	R – RED	
BL – BLUE	O – ORANGE	W – WHITE	

FIGURE 19
TYPICAL 2-STAGE THERMOSTAT: 2-STAGE/VARIABLE SPEED CONDENSING UNIT WITH ELECTRIC HEAT USING A HUMIDISTAT FOR HUMIDIFICATION

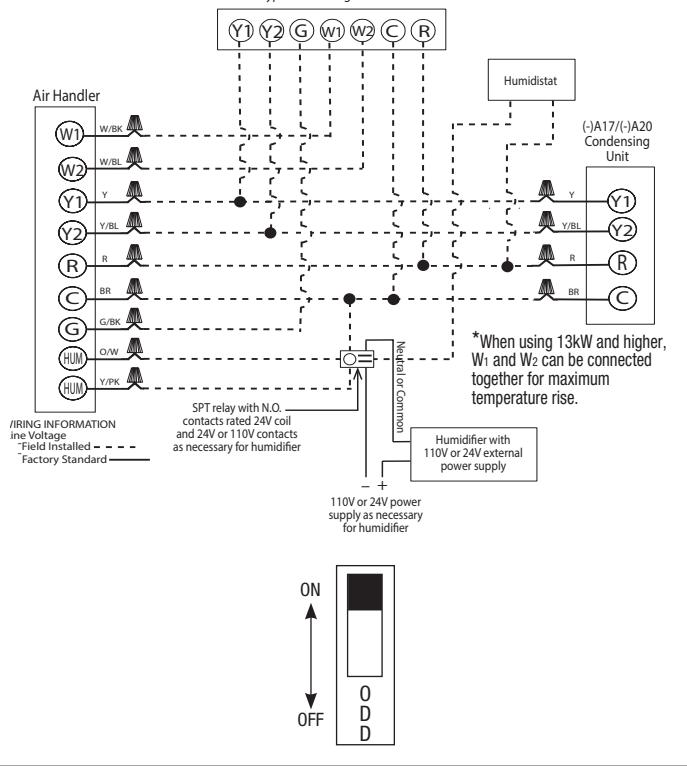

FIGURE 20
TYPICAL 2-STAGE THERMOSTAT: 2-STAGE CONDENSING UNIT WITH ELECTRIC HEAT USING A 2-STAGE/VARIABLE SPEED THERMOSTAT WITH DEHUMIDIFICATION AND HUMIDIFICATION

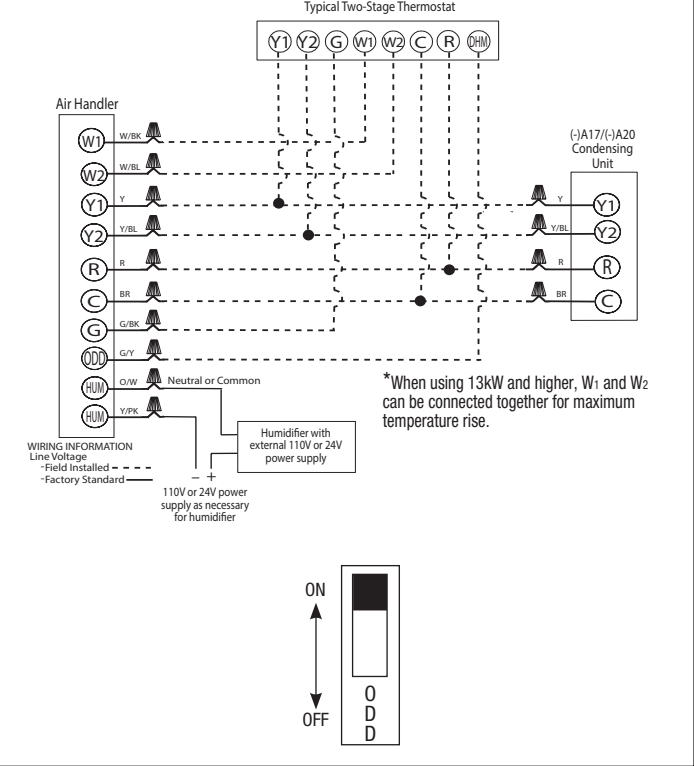
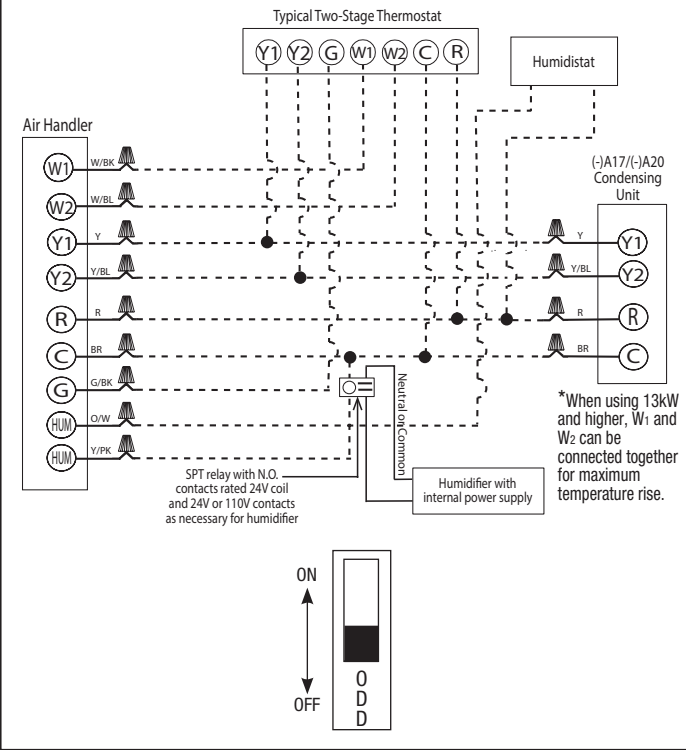
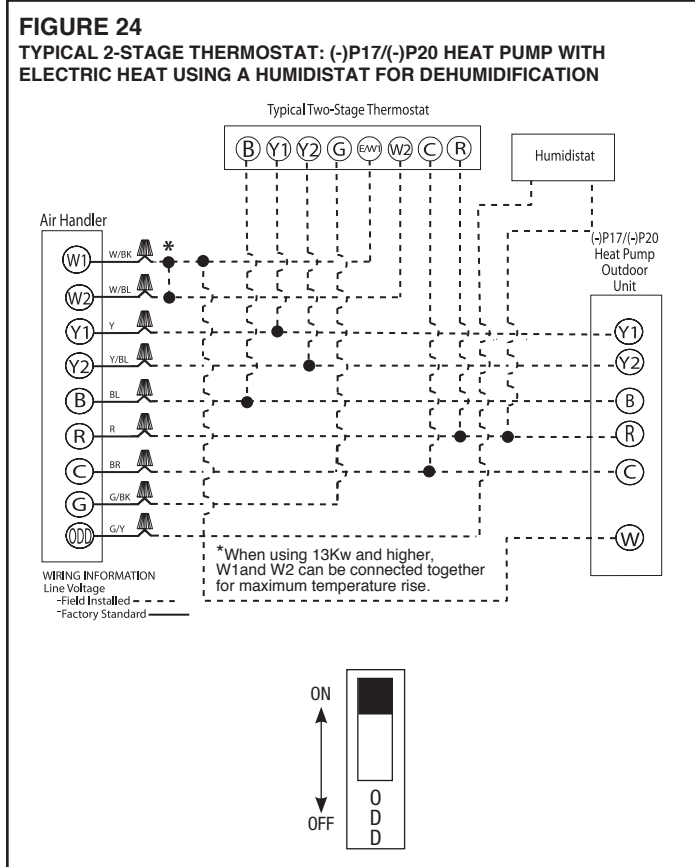
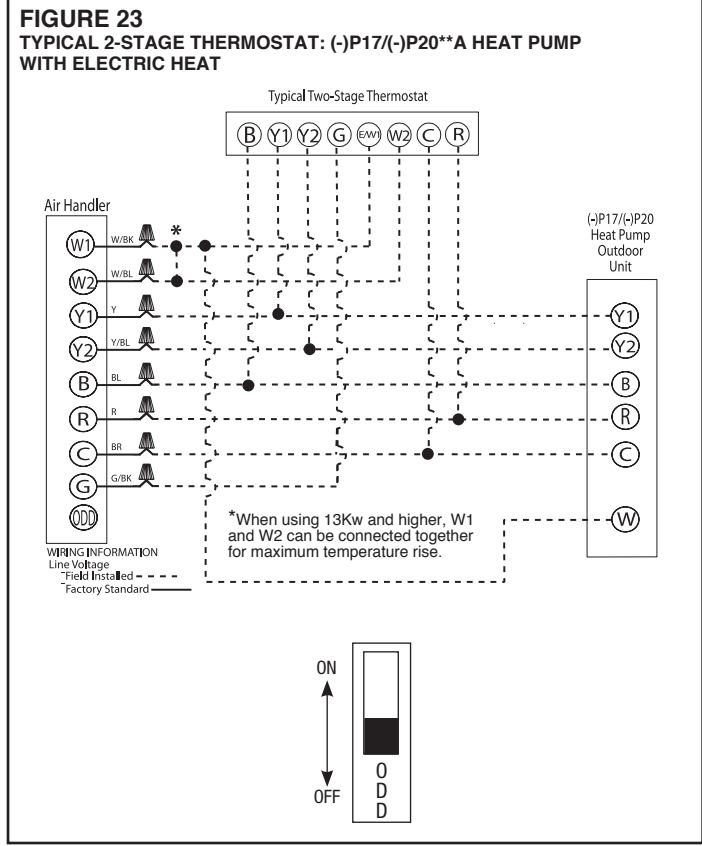
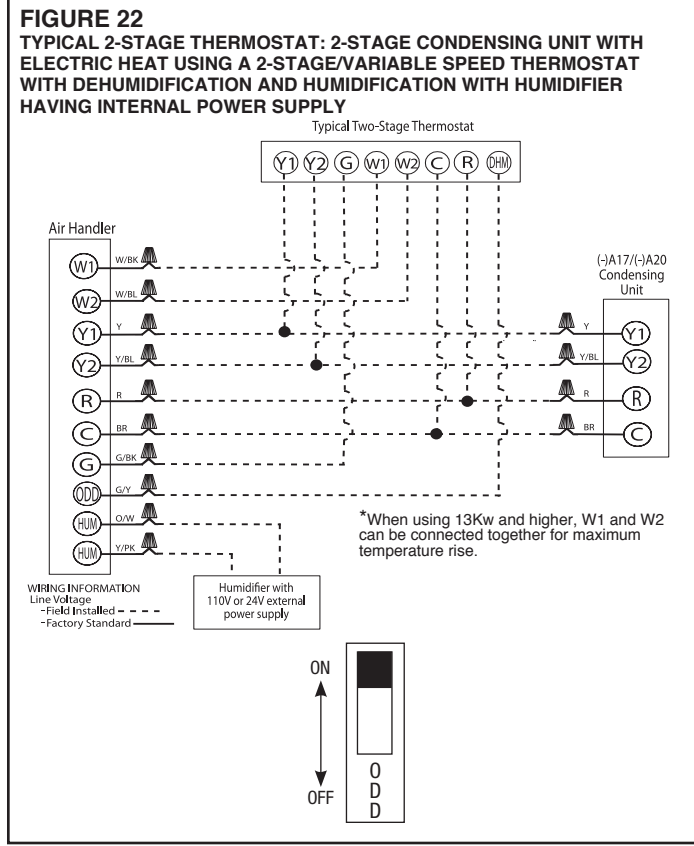

FIGURE 21
TYPICAL 2-STAGE THERMOSTAT: 2-STAGE/VARIABLE SPEED CONDENSING UNIT WITH ELECTRIC HEAT USING A HUMIDISTAT FOR HUMIDIFICATION WITH HUMIDIFIER HAVING INTERNAL POWER SUPPLY



3.12.11 CONVENTIONAL 24VAC THERMOSTAT CONTROL WIRING CONNECTION DIAGRAMS – continued

WIRE COLOR CODE			
BK – BLACK	G – GREEN	PR – PURPLE	Y – YELLOW
BR – BROWN	GY – GRAY	R – RED	
BL – BLUE	O – ORANGE	W – WHITE	



3.12.11 CONVENTIONAL 24VAC THERMOSTAT CONTROL WIRING CONNECTION DIAGRAMS – continued

WIRE COLOR CODE			
BK – BLACK	G – GREEN	PR – PURPLE	Y – YELLOW
BR – BROWN	GY – GRAY	R – RED	
BL – BLUE	O – ORANGE	W – WHITE	

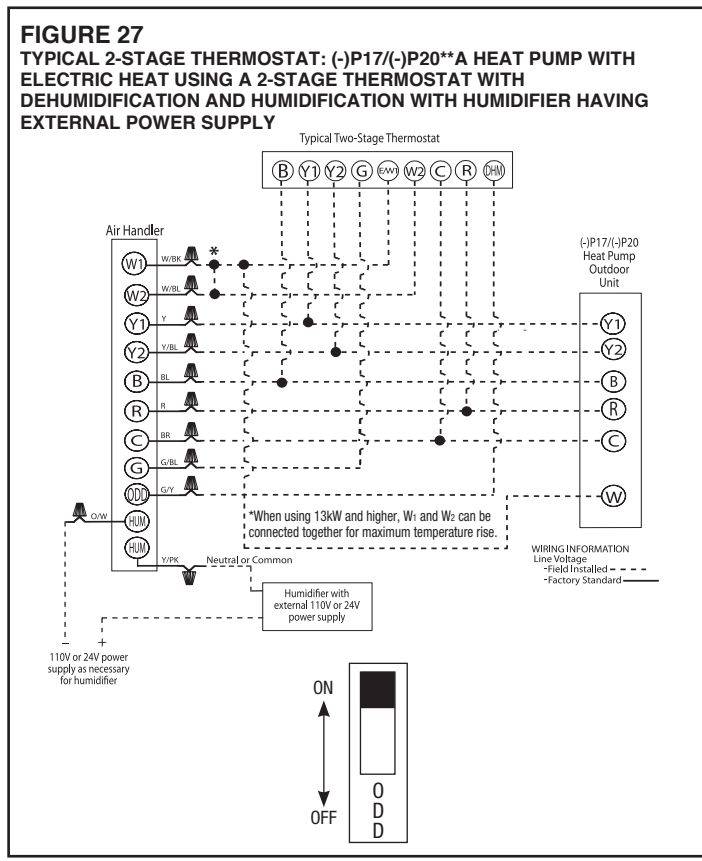
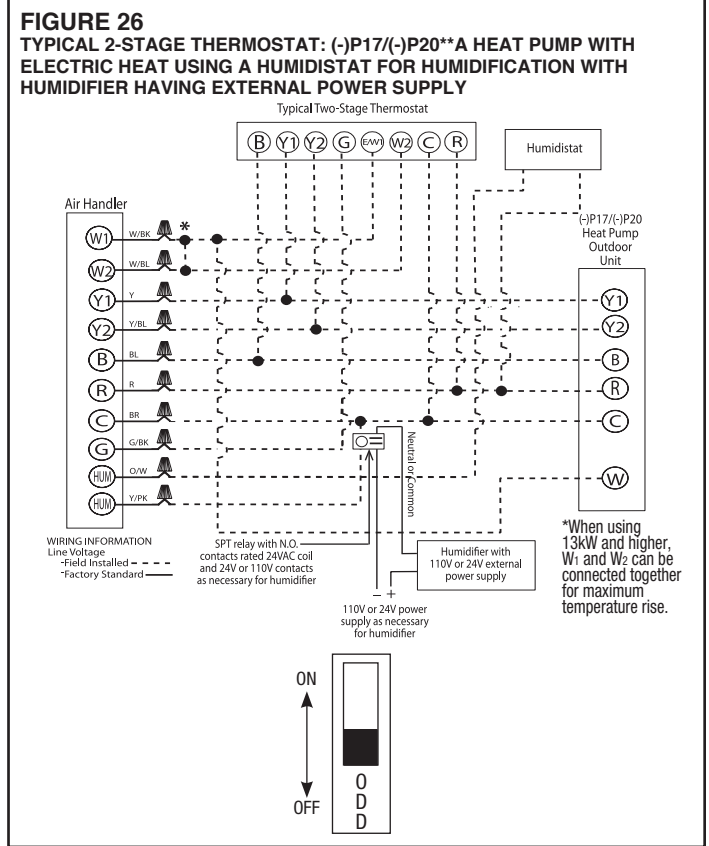
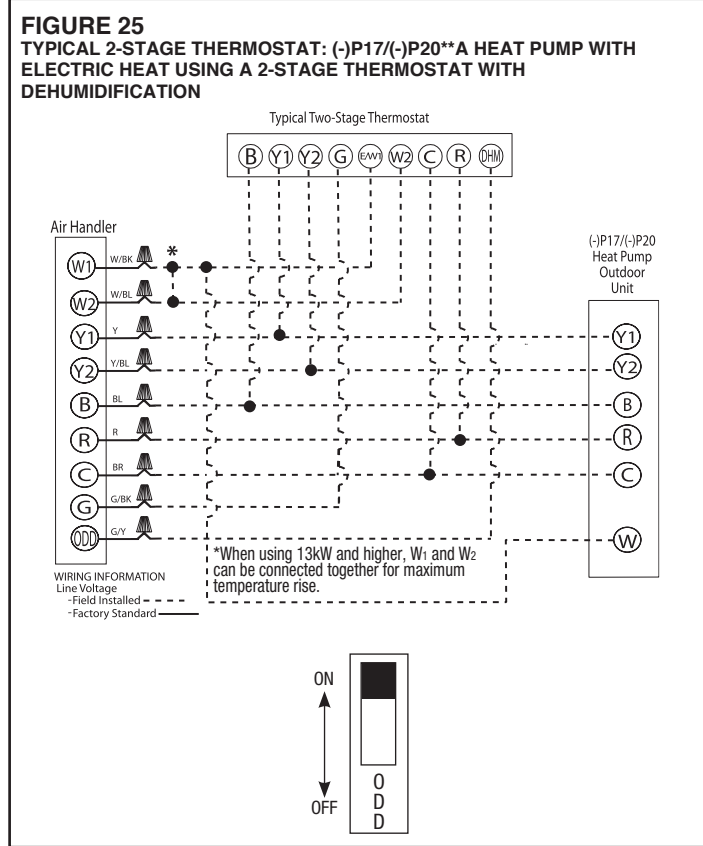

3.12.11 CONVENTIONAL 24VAC THERMOSTAT CONTROL WIRING CONNECTION DIAGRAMS – continued

WIRE COLOR CODE			
BK – BLACK	G – GREEN	PR – PURPLE	Y – YELLOW
BR – BROWN	GY – GRAY	R – RED	
BL – BLUE	O – ORANGE	W – WHITE	

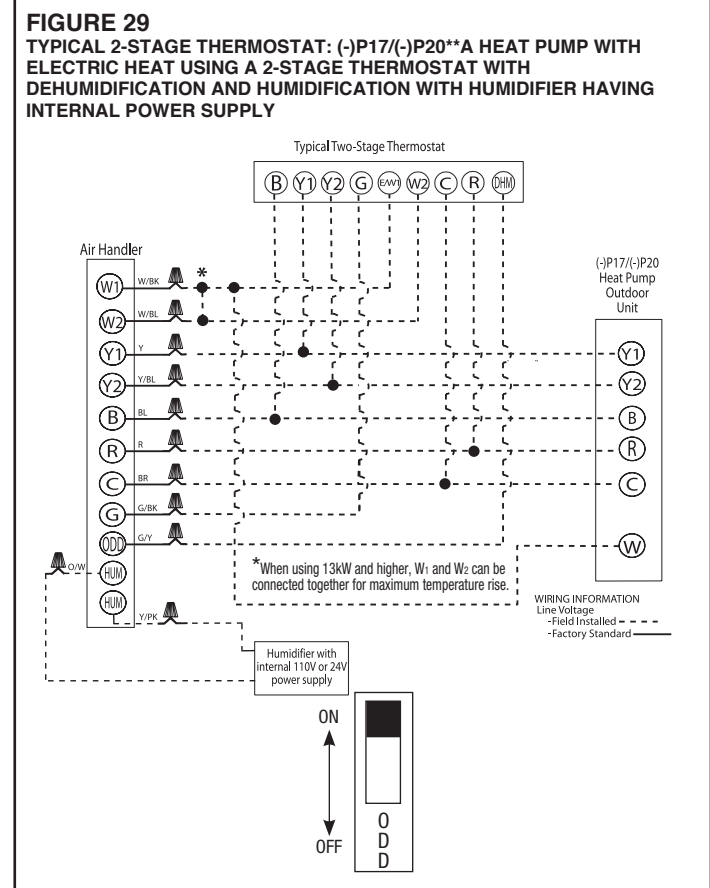
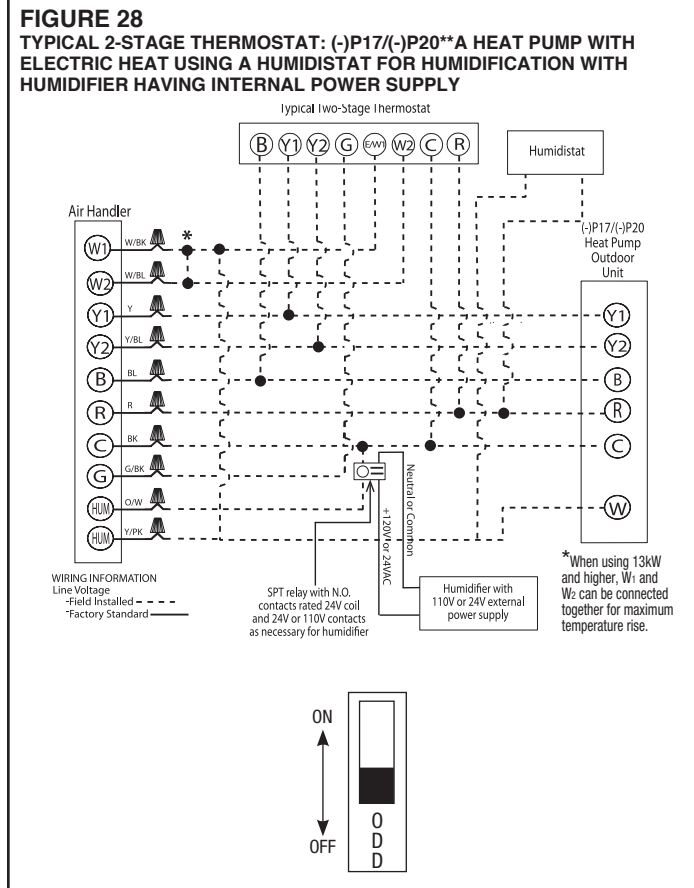

3.13 AIR-FLOW

3.13.1 GENERAL AIR-FLOW OPERATING LIMITS

Cabinet Width	17/21		17/21		21			24	
Cooling BTUH x 1,000	18	24	30	36	42	48	60	48	60
Cooling Tons Nominal	1.5	2	2.5	3	3.5	4	5	4	5
Heat Pump or Air Conditioning Maximum Heat/Cool CFM [L/s] (37.5 CFM [18 L/s]/1,000 BTUH) (450 CFM [212 L/s]/Ton Nominal)	675 [319]	900 [425]	1125 [531]	1350 [637]	1575 [743]	1800 [850]	1925 [907]	1800 [850]	1930* [911]
Heat Pump or Air Conditioning Nominal Heat/Cool CFM [L/s] (33.3 CFM [16 L/s]/1,000 BTUH) (400 CFM [189 L/s]/Ton Nominal)	600 [283]	800 [378]	1000 [472]	1200 [566]	1400 [661]	1600 [755]	1750 [826]	1600 [755]	1800* [850]
Heat Pump or Air Conditioning Minimum Heat/Cool CFM [L/s] (30.0 CFM [14 L/s]/1,000 BTUH) (360 CFM [170 L/s]/Ton Nominal)	540 [255]	720 [340]	900 [425]	1080 [510]	1260 [595]	1440 [680]	1575 [743]	1440 [680]	1620* [765]
Maximum kW Electric Heating & Minimum Electric Heat CFM [L/s]	13 487 [230]	13 617 [291]	18 814 [384]	18 1054 [497]	20 1171 [553]	25 1502 [709]	25 1502 [709]	25 1502 [709]	25 1666 [786]
Maximum Electric Heat Rise °F [°C]	80 [26.7]	63 [17.2]	66 [18.9]	51 [10.6]	49 [9.4]	50 [10]	50 [10]	50 [10]	54 [12.2]

3.13.2 (-)H2T INDOOR BLOWER MOTOR SPEED SELECTION

(-)H2T air-handlers have 5 speed ECM constant torque motors that can operate at 2 different air-flow stages based on which capacity stage the outdoor unit is operating in. The 2 stages of air-flow are selected from the 5 available speed taps on the speed tap terminal located on the motor housing. The 5 speeds provide a wide range of air-flow options for various outdoor unit match-up and for duct systems with external static pressures from 0.1 to 0.7" W.C. of external static pressure. (-)H2T air-handlers are shipped from the factory to deliver maximum air-flow using speed taps T4 and T5 for the 2 stages of air-flow (Y1 and Y2), but the lower speed taps (T1, T2, and T3) can easily be selected by moving the 2 motor lead wires connected to speed taps T4 and T5 to a lower speed taps as the specific application requires.

IMPORTANT: For optimum performance, efficiency, dehumidification, and the lowest possible noise level, it is important to select the appropriate speed taps for the specific application it is being installed in. This is dependent on the external static pressure of the duct system including the external filter as well as the specific outdoor unit being matched with the air-handler.

Selecting Speed Taps: To select the proper speed taps, first determine the rated CFM for the 1st and 2nd stages of air-flow based on the applicable indoor/outdoor unit combination in Tables 1 and 2 below. For indoor/outdoor combinations not shown in Tables 1 and 2, refer to the outdoor unit specifications or the AHRI Directory located at www.ahridirectory.org. Once the rated 2nd stage CFM has been identified, locate the air-handler model being installed in the Air-Flow Performance Table in **Section 3.13.3** and determine which motor speed tap delivers approximately the rated CFM at the total external static pressure of the duct system (ductwork, grilles, registers, and filters) at 2nd stage air-flow. Move the BLUE motor lead that is connected to T5 at the factory to the selected motor speed tap terminal. If that happens to be T4, remove the YELLOW wire from T4 and connect the BLUE wire to T4.

NOTE: The air-flow performance data in **Section 3.13.3** lists air-flow data for air-handlers without electric heaters. Air-Flow is reduced by approximately 3% if electric heaters are installed.

Next, determine which motor speed tap delivers approximately the 1st stage rated CFM at the total external static pressure at 1st stage air-flow and move the YELLOW motor lead to that motor speed tap. Keep in mind the external static pressure for 1st stage air-flow will be significantly less than external static pressure at 2nd stage air-flow. The 1st stage external static pressure (ESP) can be calculated using the following fan law formula.

$$1st\ Stage\ ESP = 2nd\ Stage\ ESP \times \left(\frac{1st\ Stage\ CFM}{2nd\ Stage\ CFM} \right)^2$$

Example for 0.5" W.C. ESP & 800 CFM for 2nd Stage, 600 CFM for 1st Stage
 $1st\ Stage\ ESP = 0.5" W.C. \times (600\ CFM \div 800\ CFM)^2 = 0.5 \times 0.75^2 = 0.5 \times 0.56 = \underline{0.28" W.C.}$

IMPORTANT: (-)P17 series heat pumps have 3 stages of capacity for the cooling and heating modes. When matched to an (-)P17 series heat pump, (-)H2T air-handlers operate at 1st stage air-flow for both the low and intermediate capacity stages and at 2nd stage air-flow for the maximum capacity stage.

NOTE: (-)H2T air-handlers operate at 2nd stage air-flow anytime the electric heat is energized.

TABLE 1
RATED AIR-FLOW FOR (-)H2T Air-HANDLERS + (-)A17 CONDENSING UNITS

Air-Handler Model	Outdoor Model	(-)H2T Air-Flow CFM [L/s]	
		Y2 (2nd Stage)	Y1 (1st Stage)
RH2T2417ST	(-)A1724A	800 [378]	600 [283]
RH2T2417SE	(-)A1724A	800 [378]	500 [236]
RH2T2421ME	(-)A1724A	700 [330]	525 [248]
RH2T3617SE	(-)A1736A	1200 [566]	625 [295]
RH2T3621ME	(-)A1736A	1050 [496]	800 [378]
RH2T4821ME	(-)A1748A	1400 [661]	1050 [496]
RH2T6024ME	(-)A1748A	1550 [732]	1175 [555]
RH2T6024ME	(-)A1760A	1550 [732]	1175 [555]
RH2T2421MT	(-)A1724A	800 [378]	600 [283]
RH2T3621MT	(-)A1736A	1075 [507]	825 [389]
RH2T4821MT	(-)A1748A	1500 [708]	1050 [496]
RH2T6024MT	(-)A1760A	1600 [755]	1300 [614]

TABLE 2
RATED AIR-FLOW FOR (-)H2T AIR-HANDLERS + (-)P17 HEAT PUMPS

Air-Handler Model	Outdoor Model	(-)H2T Air-Flow CFM [L/s]	
		Y2 (2nd Stage for Maximum Capacity)	Y1 (1st Stage for Minimum & Intermediate Capacity)
RH2T2417SE	(-)P1724A	750 [354]	525 [248]
RH2T3617SE	(-)P1736A	1225 [578]	650 [290]
RH2T4821ME	(-)P1748A	1400 [661]	850 [401]
RH2T6021SE	(-)P1760A	1575 [743]	850 [401]

3.13.3 AIRFLOW PERFORMANCE DATA: (-)H2T

Air-Handler (-)H2T	Outdoor Unit	Motor Speed From Factory	Blower			Motor Speed	CFM [L/s] Air Delivery / RPM / Watts (Dry Coil, No Filter, No Heat)													
			Size Motor HP	Size	#Speeds		External Static Pressure - Inches W.C. [kPa]													
							0.1 [.02]	0.2 [.05]	0.3 [.07]	0.4 [.10]	0.5 [.12]	0.6 [.15]	0.7 [.17]							
2417ST 2417SE No Heat	(-)A1714A (-)P1724A	Y1 tap 4 Y2 tap 5	1/3	10x8	5	1	CFM [L/s]	651 [307]	511 [241]	307 [145]	-	-	-	-						
							RPM	530	558	590	-	-	-	-						
							Watts	61	47	35	-	-	-	-						
						2	CFM [L/s]	734 [346]	526 [248]	387 [182]	-	-	-	-						
							RPM	579	580	614	-	-	-	-						
							Watts	66	46	42	-	-	-	-						
						3	CFM [L/s]	872 [412]	826 [390]	782 [369]	735 [347]	690 [326]	637 [301]	578 [273]						
							RPM	606	654	701	750	800	854	906						
							Watts	91	97	103	108	115	123	122						
2417ST 2417SE No Heat	(-)A1714A (-)P1724A	Y1 tap 4 Y2 tap 5	1/3	10x8	5	4	CFM [L/s]	918 [433]	872 [412]	829 [391]	783 [370]	738 [348]	691 [326]	638 [301]						
							RPM	627	677	724	766	816	866	917						
							Watts	103	111	116	122	128	137	141						
						5	CFM [L/s]	1047 [494]	1003 [473]	966 [456]	925 [437]	855 [418]	845 [399]	806 [380]						
							RPM	692	737	780	821	860	903	944						
							Watts	140	149	156	163	173	178	184						
						2421ME No Heat	(-)A1724A	Y1 tap 4 Y2 tap 5	1/3	10x8	5	2	CFM [L/s]	810 [382]	642 [303]	361 [170]	-	-	-	-
													RPM	477	510	555	-	-	-	-
													Watts	63	52	34	-	-	-	-
3	CFM [L/s]	939 [443]	815 [385]	666 [314]	597 [282]							547 [258]	479 [226]	433 [204]						
	RPM	537	565	59	662							738	795	852						
	Watts	91	83	72	77							87	90	100						
2421ME No Heat	(-)A1724A	Y1 tap 4 Y2 tap 5	1/3	10x8	5							4	CFM [L/s]	838 [395]	674 [318]	423 [200]	-	-	-	-
													RPM	495	527	571	-	-	-	-
													Watts	69	60	42	-	-	-	-
						5	CFM [L/s]	1038 [490]	956 [451]	931 [439]	877 [414]	842 [397]	787 [371]	749 [353]						
							RPM	581	629	677	723	722	826	879						
							Watts	120	122	132	138	149	157	168						
						3617SE No Heat	(-)A1736A (-)P1736A	Y1 tap 4 Y2 tap 5	1/2	10x8	5	1	CFM [L/s]	769 [363]	617 [291]	445 [210]	-	-	-	-
													RPM	559	580	625	-	-	-	-
													Watts	71	58	50	-	-	-	-
2	CFM [L/s]	1093 [516]	1050 [496]	1017 [480]	997 [471]							935 [441]	-	-						
	RPM	671	725	764	809							852	-	-						
	Watts	153	168	174	180							188	-	-						
3	CFM [L/s]	1310 [618]	1246 [588]	1187 [560]	1133 [535]							1084 [512]	1040 [491]	1001 [472]						
	RPM	686	746	801	851							896	936	971						
	Watts	177	201	221	237							249	257	261						
3617SE No Heat	(-)A1736A (-)P1736A	Y1 tap 4 Y2 tap 5	1/2	10x8	5	4	CFM [L/s]	1270 [599]	1237 [584]	1199 [566]	1165 [550]	1130 [533]	-	-						
							RPM	775	816	846	882	926	-	-						
							Watts	237	249	259	268	277	-	-						
						5	CFM [L/s]	-	-	-	-	1275 [602]	1244 [587]	1211 [572]						
							RPM	-	-	-	-	963	999	1029						
							Watts	-	-	-	-	338	349	363						
						3621ME No Heat	(-)A1736A	Y1 tap 4 Y2 tap 5	3/4	10x10	5	2	CFM [L/s]	814 [384]	852 [402]	776 [366]	659 [311]	599 [283]	-	-
													RPM	582	609	690	773	812	-	-
													Watts	75	86	100	110	116	-	-
3	CFM [L/s]	-	-	1096 [517]	1043 [492]							964 [455]	909 [429]	820 [387]						
	RPM	-	-	753	817							888	948	1003						
	Watts	-	-	164	178							193	207	222						
3621ME No Heat	(-)A1736A	Y1 tap 4 Y2 tap 5	3/4	10x10	5							4	CFM [L/s]	1053 [497]	1001 [472]	939 [443]	872 [412]	-	-	-
													RPM	601	660	726	803	-	-	-
													Watts	107	117	130	143	-	-	-
						5	CFM [L/s]	-	-	1305 [616]	1260 [595]	1213 [572]	1147 [541]	1107 [522]						
							RPM	-	-	829	876	927	987	1028						
							Watts	-	-	238	249	265	281	294						
						4821ME No Heat	(-)A1748A (-)P1748A	Y1 tap 4 Y2 tap 5	3/4	10x10	5	1	CFM [L/s]	865 [408]	735 [347]	648 [306]	597 [282]	538 [254]	497 [235]	435 [205]
													RPM	589	652	721	765	804	846	890
													Watts	90	86	96	102	109	114	119
2	CFM [L/s]	1104 [521]	1044 [493]	995 [470]	949 [448]							-	-	-						
	RPM	683	734	795	851							-	-	-						
	Watts	149	158	171	184							-	-	-						
3	CFM [L/s]	-	-	1399 [660]	1361 [642]							1321 [623]	1286 [607]	1242 [586]						
	RPM	-	-	940	987							1040	1075	1121						
	Watts	-	-	342	357							378	392	409						

NOTE: The addition of field installed electric heat will reduce air-flow by approximately 3%.

3.13.3 AIRFLOW PERFORMANCE DATA: (-)H2T (continued)

Air-Handler (-)H2T	Outdoor Unit	Motor Speed From Factory	Blower			Motor Speed	CFM [L/s] Air Delivery / RPM / Watts (Dry Coil, No Filter, No Heat)							
			Size Motor HP	Size	#Speeds		External Static Pressure - Inches W.C. [kPa]							
							0.1 [.02]	0.2 [.05]	0.3 [.07]	0.4 [.10]	0.5 [.12]	0.6 [.15]	0.7 [.17]	
4821ME with 13kW Heater	(-)A1748A (-)P1748A	Y1 tap 4 Y2 tap 5	3/4	10x10	5	1	CFM [L/s]	798 [377]	693 [238]	614 [290]	360 [265]	532 [251]	529 [250]	552 [261]
							RPM	581	645	700	743	777	800	813
							Watts	91	96	102	111	123	1136	152
						2	CFM [L/s]	1073 [507]	1018 [481]	970 [458]	929 [439]	-	-	-
							RPM	709	765	822	882	-	-	-
							Watts	153	164	177	192	-	-	-
						3	CFM [L/s]	-	-	1380 [651]	1341 [633]	1300 [614]	1257 [593]	1212 [572]
							RPM	-	-	963	1013	1068	1130	1198
							Watts	-	-	349	367	391	423	461
4821ME No Heat	(-)A1748A (-)P1748A	Y1 tap 4 Y2 tap 5	3/4	10x10	5	4	CFM [L/s]	1183 [558]	1140 [538]	1099 [519]	1061 [501]	-	-	-
							RPM	762	812	867	925	-	-	-
							Watts	195	208	222	236	-	-	-
						5	CFM [L/s]	-	-	1645 [777]	1604 [777]	1553 [733]	1494 [705]	1425 [673]
							RPM	-	-	1080	1113	1132	1138	1131
							Watts	-	-	535	545	541	523	491
6021ME No Heat	(-)P1760A	Y1 tap 4 Y2 tap 5	3/4	10x10	5	1	CFM [L/s]	829 [391]	757 [357]	627 [296]	562 [285]	499 [236]	435 [205]	-
							RPM	552	614	710	746	790	849	-
							Watts	68	76	85	88	91	102	-
						2	CFM [L/s]	1716 [810]	1669 [788]	1631 [770]	1594 [752]	1555 [734]	1522 [718]	1483 [700]
							RPM	861	887	911	948	984	1015	1050
							Watts	359	375	379	397	427	419	427
						3	CFM [L/s]	1841 [869]	1798 [849]	1758 [830]	1728 [816]	1699 [802]	1660 [783]	1629 [769]
							RPM	898	930	967	997	1027	1057	1092
							Watts	469	470	484	490	498	512	531
6021ME No Heat	(-)P1760A	Y1 tap 4 Y2 tap 5	3/4	10x10	5	4	CFM [L/s]	1886 [890]	1849 [873]	1809 [854]	1776 [838]	1741 [822]	1704 [804]	1677 [791]
							RPM	917	948	981	1012	1047	1076	1108
							Watts	491	501	509	525	540	560	569
						5	CFM [L/s]	2042 [964]	2003 [945]	1968 [929]	1931 [911]	1902 [898]	1868 [882]	1835 [866]
							RPM	962	994	1043	1050	1102	1135	1159
							Watts	612	632	616	649	673	657	711
6024ME No Heat	(-)A1748A (-)A1760A (-)P1760A	Y1 tap 4 Y2 tap 5	3/4	11x11	5	1	CFM [L/s]	1372 [648]	1308 [617]	1249 [589]	1187 [560]	1125 [531]	1067 [504]	998 [471]
							RPM	585	625	668	704	734	771	811
							Watts	165	176	186	195	203	210	219
						2	CFM [L/s]	1371 [647]	1304 [615]	1248 [589]	1183 [558]	1120 [529]	1057 [499]	999 [471]
							RPM	586	627	668	706	734	774	808
							Watts	166	175	185	195	200	211	219
						3	CFM [L/s]	1669 [788]	1615 [762]	1561 [737]	1513 [714]	1460 [689]	1406 [664]	1342 [633]
							RPM	690	723	759	792	818	850	878
							Watts	279	293	305	317	328	334	343
6024ME No Heat	(-)P1760A	Y1 tap 4 Y2 tap 5	3/4	11x11	5	4	CFM [L/s]	1375 [649]	1316 [621]	1257 [593]	1190 [562]	-	-	-
							RPM	593	632	673	713	-	-	-
							Watts	168	180	189	199	-	-	-
						5	CFM [L/s]	-	-	1745 [824]	1709 [807]	1649 [807]	1613 [761]	1560 [736]
							RPM	-	-	809	846	846	907	929
							Watts	-	-	397	418	418	442	450

NOTE: The addition of field installed electric heat will reduce air-flow by approximately 3%.

3.13.3 AIRFLOW PERFORMANCE DATA: (-)H2T (continued)

Air-Handler (-)H2T	Outdoor Unit	Motor Speed From Factory	Blower			Motor Speed	CFM [L/s] Air Delivery / RPM / Watts (Dry Coil, No Filter, No Heat)							
			Size Motor Hp	Size	# Speeds		External Static Pressure - Inches W.C. [kPa]							
							0.1 [.02]	0.2 [.05]	0.3 [.07]	0.4 [.10]	0.5 [.12]	0.6 [.15]	0.7 [.17]	
2421MT No Heat	(-)A1724A	Y1 tap 4 Y2 tap 5	3/4	10 x 10	5	1	CFM [L/s]	899 [424]	633 [299]	265 [125]	197 [93]	138 [65]	-	-
							RPM	568	567	612	685	742	-	-
							Watts	87	57	36	39	43	-	-
						2	CFM [L/s]	884 [417]	629 [297]	570 [269]	499 [235]	437 [206]	369 [174]	307 [145]
							RPM	566	570	631	708	781	839	891
							Watts	85	57	62	69	76	80	85
						3	CFM [L/s]	897 [423]	828 [391]	781 [369]	740 [349]	673 [318]	621 [293]	564 [266]
							RPM	566	622	682	729	794	851	911
							Watts	87	90	99	104	112	119	127
						4	CFM [L/s]	TBD	TBD	TBD	TBD	TBD	TBD	TBD
							RPM	TBD	TBD	TBD	TBD	TBD	TBD	TBD
							Watts	TBD	TBD	TBD	TBD	TBD	TBD	TBD
						5	CFM [L/s]	993 [469]	953 [450]	899 [424]	852 [402]	807 [381]	754 [356]	703 [332]
							RPM	605	654	716	766	819	866	923
							Watts	110	117	127	135	143	150	158
3621MT No Heat	(-)A1736A	Y1 tap 4 Y2 tap 5	3/4	10 x 10	5	1	CFM [L/s]	1000 [472]	926 [437]	847 [399]	775 [366]	719 [339]	646 [305]	573 [270]
							RPM	596	657	729	784	825	881	928
							Watts	97	106	116	123	129	137	144
						2	CFM [L/s]	906 [428]	656 [309]	599 [283]	517 [244]	437 [206]	363 [171]	308 [145]
							RPM	565	616	661	719	787	843	892
							Watts	81	68	73	79	85	91	96
						3	CFM [L/s]	1178 [556]	1100 [523]	1057 [499]	999 [471]	911 [430]	862 [407]	816 [385]
							RPM	660	712	769	819	881	922	955
							Watts	140	149	160	169	181	188	195
						4	CFM [L/s]	1050 [496]	991 [468]	925 [437]	827 [390]	779 [368]	714 [337]	640 [302]
							RPM	613	668	726	797	835	886	939
							Watts	107	115	124	135	141	150	158
						5	CFM [L/s]	1378 [650]	1326 [626]	1270 [599]	1215 [573]	1160 [547]	1058 [499]	1036 [489]
							RPM	739	783	832	877	924	1002	1016
							Watts	204	215	226	237	248	267	271
4821MT No Heat	(-)A1748A	Y1 tap 4 Y2 tap 5	3/4	10 x 10	5	1	CFM [L/s]	914 [431]	842 [397]	725 [342]	666 [314]	601 [283]	522 [246]	456 [215]
							RPM	585	644	715	761	809	865	913
							Watts	80	88	96	102	108	114	119
						2	CFM [L/s]	1180 [557]	1126 [531]	1067 [503]	934 [441]	909 [429]	856 [404]	796 [376]
							RPM	696	745	794	881	897	932	975
							Watts	144	152	162	176	181	187	195
						3	CFM [L/s]	1589 [750]	1548 [730]	1506 [711]	1467 [692]	1406 [663]	1358 [641]	1235 [583]
							RPM	869	906	941	976	1012	1048	1143
							Watts	304	315	326	337	348	359	387
						4	CFM [L/s]	1282 [605]	1233 [582]	1183 [558]	1105 [522]	995 [469]	976 [460]	923 [435]
							RPM	734	780	825	874	950	969	1000
							Watts	175	184	194	204	220	224	230
						5	CFM [L/s]	1659 [783]	1625 [767]	1585 [748]	1544 [729]	1501 [708]	1450 [688]	1424 [672]
							RPM	917	955	987	1023	1054	1087	1117
							Watts	363	377	388	401	411	423	433
6024MT No Heat	(-)A1760A	Y1 tap 4 Y2 tap 5	3/4	10 x 10	5	1	CFM [L/s]	1372 [648]	1308 [617]	1246 [588]	1183 [558]	1123 [530]	1053 [497]	994 [469]
							RPM	603	644	689	725	759	794	829
							Watts	171	182	193	201	210	218	227
						2	CFM [L/s]	1349 [636]	1288 [608]	1220 [576]	1161 [548]	1089 [514]	1029 [486]	963 [454]
							RPM	595	636	678	715	754	789	827
							Watts	163	174	183	192	202	210	218
						3	CFM [L/s]	1749 [825]	1699 [802]	1647 [777]	1602 [756]	1551 [732]	1506 [711]	1452 [685]
							RPM	737	769	805	833	862	888	922
							Watts	337	350	364	374	386	397	409
						4	CFM [L/s]	1449 [684]	1388 [655]	1329 [627]	1266 [597]	1202 [567]	1133 [535]	1078 [509]
							RPM	628	667	702	738	779	815	843
							Watts	197	207	217	226	236	246	253
						5	CFM [L/s]	1888 [891]	1850 [873]	1805 [852]	1751 [826]	1711 [807]	1666 [786]	1623 [766]
							RPM	793	821	848	882	906	935	961
							Watts	428	440	453	468	479	492	503

NOTE: The addition of field installed electric heat will reduce air-flow by approximately 3%.

3.13.4 (-)H2V/(-)HVM AIR-FLOW SETTINGS OVERVIEW

(-)H2V/(-)HVM air-handlers have variable speed electronically commutated motors (ECM) which deliver an optimum level of air-flow for multi-stage or variable speed system operation over a wide range of external static pressures up to 1.0" W.C. The air-flow level varies based on the percentage of full capacity the multi-stage or variable speed outdoor unit is operating at, dehumidification requirements, and if the electric heat is energized. When connected in the EcoNet™ communicating mode using the EcoNet™ Control Center and a matching EcoNet™ enabled outdoor unit, the air-flow is automatically set to the appropriate level based on the outdoor unit connected to the system. When connected to a conventional 24VAC thermostat, air-flow settings must be manually configured in the field using DIP switches located on the EcoNet™ Air-Handler Control Board to assure proper air-flow is delivered for the particular system being installed. It is also possible to configure the available dehumidification options using the menu in the EcoNet™ Control Center or using DIP switches on the control board should enhanced dehumidification be desired.

NOTE: Cooling, heat pump heating, and electric heat air-flow levels are controlled independently on (-)H2V/(-)HVM air-handlers. See Sections 3.13.5 - 3.13.8 for details on configuring the system when using EcoNet™ communication and when using a conventional 24VAC thermostat.

3.13.5 (-)H2V/(-)HVM COOLING & HEAT PUMP HEATING AIR-FLOW SETTINGS

Cooling and heat pump heating air-flow is automatically set when the EcoNet™ enabled (-)H2V and (-)HVM air-handlers are connected to an EcoNet™ Control Center and EcoNet™ enabled outdoor unit per Section 3.12.8 (EcoNet™ Communications Control Wiring) as long as the outdoor unit is approved by the manufacturer for use with the particular air-handler being installed. The (-)H2V or (-) HVM air-handler detects the model of the outdoor unit via the EcoNet™ communications and sets the air-flow characteristics for optimum performance and comfort. Refer to Tables 3-5 below for the air-flow levels when connected to the approved EcoNet™ enabled outdoor models. If desired, the cooling air-flow may be adjusted by +/-10% using the Cooling Air-Flow Trim Adjustment menu in the EcoNet™ Control Center. (See Section 3.13.5)

When an (-)HVM air-handler is matched with a variable speed (-)A20 or (-)P20 Series outdoor unit in the EcoNet™ communicating mode, the air-flow will vary based on the percentage capacity the inverter is driving the compressor, so the actual air-flow may be anywhere between the minimum and maximum air-flow at any given point in time.

TABLE 3
RATED AIR-FLOW FOR (-)H2V Air-Handler + (-)A17 CONDENSING UNITS

Air-Handler Model	Outdoor Model	RHMV Air-Flow (EcoNet™)	
		Cooling Mode CFM [L/s]	
		1st Stage	2nd Stage
RH2V2417ST RH2V2421MT	(-)A1724A	600 [283]	800 [378]
RH2V3621MT	(-)A1736A	825 [389]	1075 [507]
RH2V4821MT	(-)A2024A	1050 [496]	1500 [708]
RH2V6021ST RH2V6024SE	(-)A2060A	1300 [614]	1600 [755]

TABLE 4
RATED AIR-FLOW FOR (-)HVM Air-Handler + (-)A17 & (-)A20 CONDENSING UNITS

Air-Handler Model	Outdoor Model	RHMV Air-Flow (EcoNet™)		
		Cooling Mode CFM [L/s]		
		Maximum	Intermediate	Minimum
RHMV2417SE	(-)A1724A	725 [342]	-	525 [248]
RHMV2421ME	(-)A1724A	725 [342]	-	525 [248]
RHMV3617SE	(-)A1736A	1075 [507]	-	825 [389]
RHMV6021SE	(-)A1736A	1075 [507]	-	825 [389]
RHMV6024ME	(-)A1736A	1075 [507]	-	825 [389]
RHMV6021SE	(-)A1748A	1400 [661]	-	1050 [496]
RHMV6024ME	(-)A1748A	1400 [661]	-	1050 [496]
RHMV6021SE	(-)A1760A	1550 [732]	-	1175 [554]
RHMV6024ME	(-)A1760A	1550 [732]	-	1175 [554]
RHMV2417SE	(-)A2024A	825 [389]	450 [212]	300 [142]
RHMV2421ME	(-)A2024A	825 [389]	460 [217]	300 [142]
RHMV2421HE	(-)A2024A	825 [389]	450 [212]	300 [142]
RHMV6021SE	(-)A2036A	1225 [578]	665 [314]	500 [236]
RHMV6024ME	(-)A2036A	1225 [578]	650 [307]	525 [248]
RHMV6021SE	(-)A2048A	1550 [732]	830 [392]	475 [224]
RHMV6024ME	(-)A2048A	1675 [791]	750 [354]	500 [236]
RHMV6021SE	(-)A2060A	1625 [767]	850 [401]	575 [271]
RHMV6024ME	(-)A2060A	1650 [779]	920 [434]	500 [236]

TABLE 5
RATED AIR-FLOW FOR (-)HVM Air-Handler + (-)P17 & (-)P20 HEAT PUMPS

Air-Handler Model	Outdoor Model	RHMV Air-Flow (EcoNet™)					
		Cooling Mode CFM [L/s]			Heat Pump Heating Mode CFM [L/s]		
		Maximum	Intermediate	Minimum	Maximum	Intermediate	Minimum
RHMV2417SE	(-)A1724A	750 [354]	525 [248]	525 [248]	750 [354]	550 [260]	550 [260]
RHMV3617SE	(-)A1736A	1225 [578]	650 [307]	650 [307]	1225 [578]	700 [330]	675 [319]
RHMV6021SE	(-)A1736A	1425 [673]	850 [401]	850 [401]	1425 [673]	875 [413]	850 [401]
RHMV6021SE	(-)A1736A	1575 [743]	875 [413]	875 [413]	1575 [743]	825 [389]	825 [389]
RHMV2421HE	(-)A2024A	850 [401]	580 [273]	300 [142]	850 [401]	650 [307]	575 [271]
RHMV6021SE	(-)A2036A	1175 [554]	720 [340]	600 [283]	1175 [554]	925 [437]	625 [295]
RHMV6021SE	(-)A2048A	1650 [779]	875 [413]	550 [260]	1650 [779]	825 [389]	550 [260]
RHMV6024ME	(-)A2060A	1750 [826]	750 [354]	575 [271]	1750 [826]	1300 [614]	1200 [566]

When a conventional 24VAC thermostat is used with an (-)H2V or (-)HVM air-handler, the air-flow must be set manually using the CAF and PAF DIP switches located on the EcoNet™ Air-Handler Control Board. (See Figures 30, 34 and 35) Not all (-)HVM + outdoor unit combinations that are approved for use with the for EcoNet™ communications are approved for use using the air-flow DIP switch settings due to the DIP switch air-flow levels not being appropriate for some combinations. Refer to Tables 6-8 below for approved combinations and the corresponding air-flow DIP switch settings.

IMPORTANT: Matching non-approved combinations in 24VAC thermostat applications will result in unsatisfactory operation of the system.

NOTE: When utilizing the (-)HVM air handlers with a 24VAC thermostat, the low stage airflow will be held with a Y1 signal for 15 minutes before the air handler automatically stages to the INTERMEDIATE airflow setting.

TABLE 6
AIR-FLOW DIP SWITCH SETTING FOR (-)H2V Air-Handler + (-)A17 CONDENSING UNITS

Air-Handler Model	Outdoor Model	Cooling DIP Switch Profile (CAF)	RHMV Air-Flow (EcoNet™)	
			Cooling Mode CFM [L/s]	
			1st Stage	2nd Stage
RH2V2417ST RH2V2417MT	(-)A1724A	A*	600	800
RH2V3621MT	(-)A1736A	A*	825	1075
RH2V4821MT	(-)A2024A	A*	1050	1500
RH2V6021ST RH2V6024SE	(-)A2060A	A*	1300	1600

***Factory setting**

NOTES: 1) Air-flow DIP switch setting are ignored if the system is weird for the EcoNet™ Communicating Mode.

2) When a conventional 24VAC 2-Stage thermostat is used to control the system, the 1st Stage air-flow will be delivered if only Y1 is energized. 2nd Stage air-flow Y1 and Y2 is energized.

TABLE 7
AIR-FLOW DIP SWITCH SETTING FOR (-)HVM Air-Handler + (-)A17 & (-)A20 CONDENSING UNITS

Air-Handler Model	Outdoor Model	Cooling DIP Switch Profile (CAF)	RHMV Air-Flow (EcoNet™)		
			Cooling Mode CFM [L/s]		
			Maximum	Intermediate	Minimum
RHMV2417SE	(-)A1724A	A	750 [354]	550 [260]	550 [260]
RHMV3617SE	(-)A1736A	A	1235 [583]	660 [312]	660 [312]
RHMV2417SE	(-)A2024A	A	750 [354]	550 [260]	550 [260]
RHMV2421ME	(-)A2024A	A	835 [394]	460 [217]	310 [146]
RHMV2421HE	(-)A2024A	A	855 [404]	580 [274]	325 [153]
RHMV6021SE	(-)A2036A	C	1235 [583]	660 [312]	410 [194]
RHMV6021SE	(-)A2048A	B	1565 [739]	835 [394]	520 [245]
RHMV6024ME	(-)A2048A	A	1670 [788]	755 [356]	500 [236]
RHMV6021SE	(-)A2060A	A	1660 [784]	885 [418]	555 [262]
RHMV6024ME	(-)A2060A	A	1670 [788]	755 [356]	500 [236]

NOTES: 1) Air-flow DIP switch setting are ignored if the system is weird for the EcoNet™ Communicating Mode.

2) When a conventional 24VAC 2-Stage thermostat is used to control the system, the MINIMUM air-flow will be delivered for the first 15 minutes of operation when only the first stage (Y1) is energized and then the air-flow will automatically increase to the INTERMEDIATE air-flow. MAXIMUM air-flow will be delivered if 2nd stage (Y2) is energized.

3) Only the air-handler/outdoor unit combinations listed in the table are approved for conventional 24VAC thermostat applications. If there is a combination listed in the AHRI Directory that does not appear in the table, an EcoNet™ Control Center is required for proper operation and air-flow levels.

TABLE 8
RATED AIR-FLOW FOR (-)HVM Air-Handler + (-)P17 & (-)P20 HEAT PUMPS

Air-Handler Model	Outdoor Model	Cooling DIP Switch Profile (CAF)	Heating DIP Switch Profile (CAF)	RHMV Air-Flow (EcoNet™)					
				Cooling Mode CFM [L/s]			Heat Pump Heating Mode CFM [L/s]		
				Maximum	Intermediate	Minimum	Maximum	Intermediate	Minimum
RHMV2417SE	(-)A1724A	A	A	750 [354]	550 [260]	550 [260]	750 [354]	540 [255]	540 [255]
RHMV3617SE	(-)A1736A	A	A	1225 [578]	660 [312]	660 [312]	1225 [578]	660 [312]	660 [312]
RHMV2421HE	(-)A2024A	A	A	855 [404]	580 [274]	325 [153]	855 [404]	655 [309]	565 [267]
RHMV6021SE	(-)A2036A	D	D	1200 [566]	640 [302]	400 [189]	1200 [566]	640 [302]	455 [215]
RHMV6021SE	(-)A2048A	B	B	1565 [739]	835 [394]	520 [245]	1600 [755]	855 [404]	610 [288]
RHMV6024ME	(-)A2060A	A	A	1670 [788]	755 [356]	500 [236]	1670 [788]	1300 [614]	1200 [566]

NOTES: 1) Air-flow DIP switch setting are ignored if the system is weird for the EcoNet™ Communicating Mode.

2) When a conventional 24VAC 2-Stage thermostat is used to control the system, the MINIMUM air-flow will be delivered for the first 15 minutes of operation when only the first stage (Y1) is energized and then the air-flow will automatically increase to the INTERMEDIATE air-flow. MAXIMUM air-flow will be delivered if 2nd stage (Y2) is energized.

3) Only the air-handler/outdoor unit combinations listed in the table are approved for conventional 24VAC thermostat applications. If there is a combination listed in the AHRI Directory that does not appear in the table, an EcoNet™ Control Center is required for proper operation and air-flow levels.

FIGURE 30
(-)H2V/(-)H MV COOLING AND HEAT PUMP HEATING DIP SWITCH PROFILES

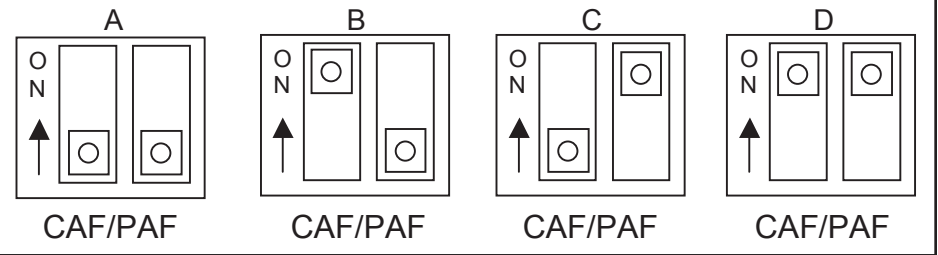

3.13.6 (-)H2V/(-)H MV COOLING AIR-FLOW TRIM ADJUSTMENT

The **EcoNet™ Air Handler Control** board allows the installer to tweak the cooling CFM by +/-10% to suit the installation. When using the **EcoNet™ Air Handler Control** in communicating mode, the CFM can only be adjusted using the **EcoNet™ Control Center**. To adjust the airflow, go to the Installer menu under settings and select the desired adjustment. (Refer to the following table).

Menu Option	Result
None	No airflow adjustment is made
High	+10%
Low	-10%

IMPORTANT: Cooling airflow adjustment is accessible via the **EcoNet™ Control Center** or via a service tool. Refer to their instructions to access the cooling airflow adjustment menu.

NOTE: Cooling air-flow adjustments affect cooling operation only. They are ignored when in the heat pump heating mode or when electric heat is activated.

Note: The trim adjustments are available for the (-)H MV air handlers ONLY.

For non-communicating installations of the (-)H MV air handlers, use the TRIM dip switches shown in Figure 31 below to select the air-flow adjustments.

FIGURE 31
(-)H MV COOLING AIR-FLOW TRIM DIP SWITCH SETTINGS

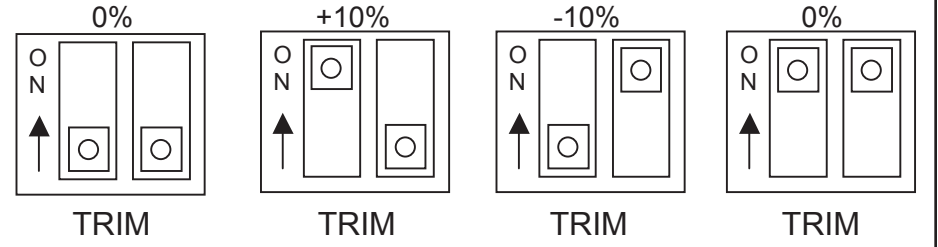

IMPORTANT: The DIP switches are active only when using a conventional 24VAC thermostat with (-)H MV air-handlers. The dip switches are not active in the (-)H2T air handlers.

3.13.7 (-)H2V/(-)H MV ELECTRIC HEAT AIR-FLOW SETTINGS

(-)H2V/(-)H MV air-handlers are shipped from the factory to deliver adequate air-flow for the maximum electric heat kW allowed for that specific model which may result in the discharge air temperature being too low and uncomfortable in applications when a much lower kW heater is installed. This can be remedied by reducing the electric heat air-flow level through changing the electric heat air-flow setting in the menu of the **EcoNet™ Control Center** or using DIP switches located on the **EcoNet™ Air-Handler Control Board** when the system is being controlled by a conventional 24VAC thermostat. Refer to the **EcoNet™ Control Center** instructions and Table 7 below for adjusting the electric heat air-flow in the **EcoNet™** communicating applications. Refer to Table 7 and Figure 32 below for adjusting the electric heat air-flow using the “HTR” DIP switches in conventional 24VAC thermostat applications.

For applications using a conventional 24VAC thermostat, the electric heat air-flow for (-)H2V/(-)H MV air-handlers can be adjusted using the DIP switches on the **EcoNet™ Air-Handler Control Board** labeled “HTR”.

TABLE 9
(-)H2V/(-)HMV ELECTRIC HEAT AIR-FLOW SETTINGS

Air-Handler Model	Electric Heat Airflow Selection	Airflow	Electric Heat Size
(-)HMV2417SE	Airflow 1	800	3kW to 10kW
	Airflow 2	600	3kW to 10kW
	Airflow 3	800	3kW to 10kW
	Airflow 4	600	3kW to 10kW
(-)H2V2417ST (-)H2V2421MT (-)HMV2421ME	Airflow 1	800	3kW to 10kW
	Airflow 2	600	3kW to 10kW
	Airflow 3	800	3kW to 10kW
	Airflow 4	600	3kW to 10kW
(-)HMV2421HE	Airflow 1	800	3kW to 10kW
	Airflow 2	600	3kW to 10kW
	Airflow 3	800	3kW to 10kW
	Airflow 4	600	3kW to 10kW
(-)HMV2421UE	Airflow 1	800	3kW to 10kW
(-)H2V3621MT (-)HMV3617SE	Airflow 1	1200	15kW to 18kW
	Airflow 2	600	3kW to 10kW
	Airflow 3	1000	15kW to 18kW
	Airflow 4	600	3kW to 10kW
(-)H2V4821MT (-)H2V6021ST (-)HMV6021SE	Airflow 1	1600	Below 25kW
	Airflow 2	1600	Below 25kW
	Airflow 3	800	15kW to 18kW
	Airflow 4	600	3kW to 10kW
(-)H2V6024MT (-)HMV6024ME	Airflow 1	1725	20kW to 25kW
	Airflow 2	800	3kW to 10kW
	Airflow 3	1600	20kW to 25kW
	Airflow 4	800	15kW to 18kW

FIGURE 32
(-)HMV ELECTRIC HEAT AIR-FLOW DIP SWITCH SETTINGS

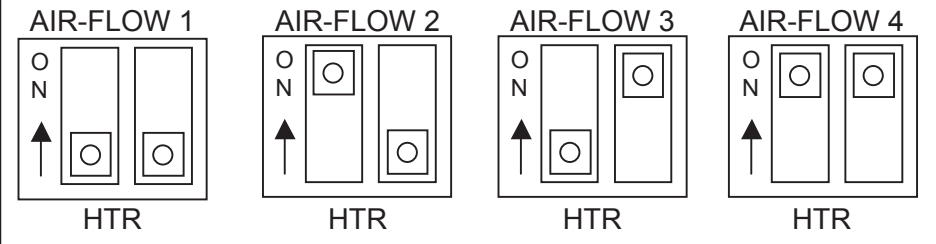

NOTE: If supplemental heat is energized during the heat pump heating mode, the air-flow will revert to the selected electric heat CFM.

3.13.8 (-)H2V/(-)HMV COOLING MODE DEHUMIDIFICATION

FIGURE 33
ON-DEMAND DEHUMIDIFICATION DIP SWITCH

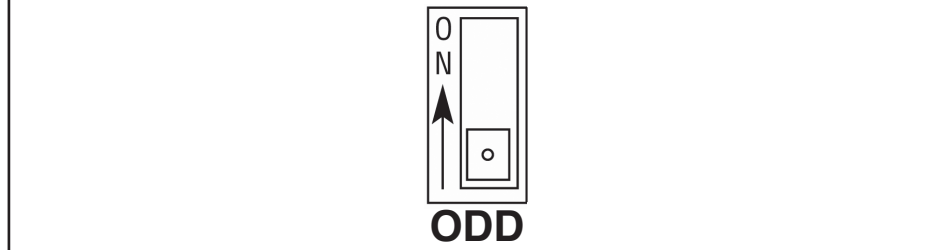

The EcoNet™ air handler control is shipped with “On Demand Dehumidification” (ODD) turned OFF. On Demand Dehumidification may be activated when the **EcoNet™ Control System™** has an on-board humidity sensor.

IMPORTANT: On Demand Dehumidification is accessible via the **EcoNet™ Control System™** or via a service tool. Refer to their instructions to access the ODD airflow adjustment menu.

The (-)H2V/(-)HMV-series air handler is shipped with “On Demand Dehumidification” (ODD) turned OFF. If Demand Dehumidification is used in conjunction with a traditional 24VAC thermostat equipped with an on-board humidity sensor, or a humidistat, activate ODD by turning DIP switch “ODD” ON. ODD operation is controlled by the indoor humidity sensed at the **EcoNet™ Control Center**, dehumidifying thermostat, or humidistat. Operation is:

Normal Humidity (humidity BELOW the humidity set point):

Normal Humidity	Result
A 24VAC signal is applied to the ODD terminal	Full rated airflow is delivered by the blower

High Humidity (humidity ABOVE the humidity set point):

High Humidity	Result
No signal (0 VAC) applied to the ODD terminal	Airflow is reduced by 15% to increase latent capacity

IMPORTANT: The ODD DIP switch is active only when using conventional a 24VAC thermostat. If using the **EcoNet™ Control System**, refer to the **EcoNet™ Control Center** instructions for enabling on-demand dehumidification.

NOTE: ODD airflow adjustments are active for cooling operation only. They are ignored when the heat pump is in the heating mode or anytime electric heat is activated.

3.13.9 USING THE ON-BOARD LED TO DETERMINE BLOWER CFM: (-)H2V/(-)HMV ONLY

On (-)H2V/(-)HMV models, the CFM LED indicates blower output by flashing one (1) time for every 100 CFM of air-flow. The LED will pause 1/10 second between each flash.

4.0 START-UP

4.1 PRE-START CHECKLIST

PRE-START CHECKLIST	
<input type="checkbox"/> YES <input type="checkbox"/> NO	Is unit properly located, level, secure and service-able?
<input type="checkbox"/> YES <input type="checkbox"/> NO	Has auxiliary pan been provided under the unit with separate drain? (Units installed above a finished ceiling).
<input type="checkbox"/> YES <input type="checkbox"/> NO	Is condensate line properly sized, run, trapped, pitched and tested?
<input type="checkbox"/> YES <input type="checkbox"/> NO	Is ductwork correctly sized, run, taped and insulated?
<input type="checkbox"/> YES <input type="checkbox"/> NO	Have all cabinet openings and wiring been sealed with caulking?
<input type="checkbox"/> YES <input type="checkbox"/> NO	Is the filter clean, in place and of adequate size?
<input type="checkbox"/> YES <input type="checkbox"/> NO	Is the wiring tight, correct and to the wiring diagram?
<input type="checkbox"/> YES <input type="checkbox"/> NO	Is the unit properly grounded and protected (fused)?
<input type="checkbox"/> YES <input type="checkbox"/> NO	Is the thermostat heat anticipator been set properly?
<input type="checkbox"/> YES <input type="checkbox"/> NO	Is the unit circuit breaker(s) rotated properly “on” up - “off” down?
<input type="checkbox"/> YES <input type="checkbox"/> NO	Are the unit circuit breaker(s) line lug cover(s) in place?
<input type="checkbox"/> YES <input type="checkbox"/> NO	Are all access panels in place and secure?
Refer to outdoor unit installation instructions for system start-up instructions and refrigerant charging instructions.	

4.2 SYSTEM START-UP AND OPERATIONAL CHECK-OUT

After the air-handler and other system components have been installed and the Pre-Start Checklist has been completed, the system should be started up and an operational check-out should be performed. The operational check-out includes checking sequence of operation of the controls, air-flow, and refrigerant charge. If the controls are not found to be functioning properly, or the air-flow or refrigerant charge are not within specifications, corrective action must be taken. The following sections are provided to assist the installer with the operational check-out.

4.3 ECONET™ COMMUNICATION VERIFICATION

Before a system wiring for EcoNet™ communications is started up for the first time, it is important to verify the system is communicating properly using the following procedure.

- 1) Make sure the E1, E2, R, and C terminals are connected to the corresponding terminals on the air-handler, outdoor unit, and EcoNet™ Control Center.
- 2) Both SH DIP switches should be in the OFF position.
- 3) Turn on the electrical power to both the air-handler and the outdoor unit.
- 4) LED 1 and 2 should flash green and red if operation is normal. A flashing green LED indicates communications are being received from the other EcoNet™ enabled controls on the communication bus. A flashing red LED indicates communications are being transmitted to the other EcoNet™ enabled controls on the communication bus. When both LED's are flashing, the E1 and E2 wires are connected correctly and the EcoNet™ communications are working properly.

IMPORTANT: The diagnostic port is not a phone jack. Connecting to a telephone or telephone system will result in a loss of communication between the EcoNet™ enabled controls.

4.4 SEQUENCE OF OPERATION

4.4.1 COOLING MODE: (-)H2T

When the EcoNet™ Control Center or conventional 24VAC 2-stage thermostat calls for the 1st stage of cooling (Y1), the EcoNet™ Air-Handler Control Board energizes its G/ Low terminal and yellow motor speed tap lead with 24VAC which energizes 1st stage air-flow (low speed). The motor will ramp up over a 15 second period and will continue to operate at 1st stage air-flow (low speed) as long as there is a call for 1st stage cooling. If 2nd stage of cooling (Y2) is called for, the EcoNet™ Air-Handler Control Board energizes its SPD terminal and blue motor speed tap lead with 24VAC which causes the motor to ramp up to 2nd stage air-flow (high speed). As the EcoNet™ Control Center or 2-stage thermostat cycles between the 1st and 2nd stages of cooling, the motor will cycle between high and low speed as directed by the control board. When the call for cooling has ended, the motor will continue to operate on low speed for an additional 30 seconds to extract the residual cooling from the cold indoor coil.

4.4.2 COOLING MODE: (-)H2V

When wired for EcoNet™ communications, the EcoNet™ Control Center will which stage of cooling is necessary and will then communicate this information to the EcoNet™ Air-Handler Control Board. The control board will then communicate with the variable speed ECM motor and EcoNet™ enabled outdoor unit to direct the motor to start and operate at either the 1st or 2nd stage cooling air-flow level based on the model data contained in the outdoor unit memory card. Upon a call for 1st stage cooling, the EcoNet™ Air-Handler Control Board communicates with the variable speed ECM motor to operate at the 1st stage air-flow level. If the EcoNet™ Control Center calls for 2nd stage cooling, the EcoNet™ Air-Handler Control Board will communicate with the motor to ramp up to the 2nd stage air-flow level. As the Control Center cycles between the 1st and 2nd stages, the indoor motor will cycle between the 1st and 2nd stage air-flow levels while the 2-stage outdoor unit cycles between its 1st and 2nd stage capacities. When the call for cooling has ended, the control board will direct the motor to operate at the minimum air-flow level for 45 seconds to extract the residual cooling from the cold indoor coil before it directs the motor to stop.

When a conventional 24VAC 2-stage thermostat calls for 1st stage cooling, the EcoNet™ Air-Handler Control Board communicates with the variable speed ECM motor to operate at the 1st stage air-flow level set using the cooling air-flow and trim DIP switches described in Sections 3.13.5 and 3.13.6. If the thermostat calls for 2nd stage cooling, the control board will communicate with the motor to ramp up to the 2nd stage air-flow level. As the 2-stage thermostat cycles between the 1st and 2nd stages, the indoor motor will cycle between the 1st and 2nd stage air-flow levels as directed by the control board while the 2-stage outdoor unit cycles between its 1st and 2nd stage capacities.

When the call for cooling has ended, the control board will direct the motor to operate at the minimum air-flow level for 45 seconds to extract the residual cooling from the cold indoor coil before it directs the motor to stop.

4.4.3 COOLING MODE: (-)H MV

When wired for EcoNet™ communications, the EcoNet™ Control Center will determine when cooling is necessary and the percentage of capacity required and will then communicate this information to the EcoNet™ Air-Handler Control Board. The control board will then communicate with the variable speed ECM motor and EcoNet™ enabled outdoor unit to direct the motor to start and operate at the appropriate cooling air-flow level based on the outdoor unit model and the percentage capacity the outdoor unit is operating at throughout the call for cooling. The air-flow level will vary as required. When the call for cooling has ended, the control board will direct the motor to operate at the minimum air-flow level for 45 seconds to extract the residual cooling from the cold indoor coil before it directs the motor to stop.

When a conventional 24VAC 2-stage thermostat calls for 1st stage cooling, the EcoNet™ Air-Handler Control Board communicates with the variable speed ECM motor to operate at minimum cooling air-flow level set using the cooling air-flow and trim DIP switches described in Sections 3.13.5 and 3.13.6. After 15 minutes of operation at the minimum air-flow level, the control board communicates with the motor to ramp up to intermediate air-flow and will continue to operate at the intermediate air-flow level as long as the 1st stage call is present. If the thermostat calls for 2nd stage cooling, the control board will communicate with the motor to ramp up to the maximum air-flow level. The outdoor unit will also ramp up to its maximum capacity. As the 2-stage thermostat cycles between the 1st and 2nd stages, the motor will cycle between the intermediate and maximum air-flow levels as directed by the control board while the (-)A17 outdoor unit cycles between its 1st and 2nd stage capacity or for an (-)A20 outdoor unit, its intermediate and maximum capacity (20 SEER). When the call for cooling has ended, the control board will direct the motor to operate at the minimum air-flow level for 45 seconds to extract the residual cooling from the cold indoor coil before it directs the motor to stop.

4.4.4 ELECTRIC HEAT MODE: (-)H2T

When the EcoNet™ Control Center or conventional 24VAC 2-stage thermostat calls for the 1st stage of electric heat, the EcoNet™ Air-Handler Control Board energizes its SPD terminal and blue motor speed tap lead (2nd stage) with 24VAC and will also energize all of the electric heater elements for heater kits with 10kW of heat or less and the 1st stage elements for 13kW heater kits and higher. The motor will ramp up to 2nd stage air-flow (high speed) over a 15 second period. If the EcoNet™ Control Center or 2-stage thermostat calls for a 2nd stage of electric heat when a 13kW or higher heater kit is installed, the 2nd stage of electric heat will be energized. The electric heater will cycle between the 1st and 2nd stages of heat at the direction of the EcoNet™ Control Center or thermostat. When the call for heat is satisfied, the heating elements will be de-energized in approximately one minute as the bimetallic disc sequencer relays in the heater assembly cool down and their contacts open. The motor will be de-energized 75 seconds after the call for electric heat ends to allow time for the heating elements to cycle off.

4.4.5 ELECTRIC HEAT MODE: (-)H2V/(-)H MV

When the EcoNet™ Control Center or conventional 24VAC 2-stage thermostat calls for the 1st stage of electric heat, the EcoNet™ Air-Handler Control Board will communicate to the variable speed ECM motor to ramp up to the electric heat air-flow level selected using the HTR DIP switches described in Section 3.13.7. The motor will ramp up to speed over a 15 second period. The control board will also energize all of the electric heater elements for heater kits with 10kW of heat or less and the 1st stage elements for 13kW heater kits and higher. If the EcoNet™ Control Center or 2-stage thermostat calls for a 2nd stage of electric heat when a 13kW or higher heater kit is installed, the 2nd stage of electric heat will be energized. The electric heater will cycle between the 1st and 2nd stages of heat at the direction of the EcoNet™ Control Center or thermostat. When the call for heat is satisfied, the heating elements will be de-energized in approximately one minute when the bimetallic disc sequencer relays in the heater assembly cool down and their contacts open. The motor will be de-energized 75 seconds after the call for electric heat ends to allow time for the heating elements to cycle off.

4.4.6 HEAT PUMP HEATING MODE: (-)H2T

When the EcoNet™ Control Center calls for the minimum or intermediate stages of heat pump heating, the EcoNet™ Air-Handler Control Board energizes its G/Low terminal and yellow motor speed tap lead with 24VAC which energizes 1st stage air-flow (low speed). The motor will ramp up over a 15 second period and continue operating at 1st stage air-flow (low speed) as long as there is a call for the minimum or intermediate stages of heat. The heat pump outdoor unit will cycle between its minimum or intermediate capacity modes at the direction of the EcoNet™ Control Center while the indoor air-flow remains constant. If the 3rd or maximum stage of heating is called for, the EcoNet™ Air-Handler Control Board energizes its SPD terminal and blue motor speed tap lead with 24VAC which energizes 2nd stage air-flow (high speed). As the EcoNet™ Control Center cycles between the intermediate and maximum capacity stages, the motor will cycle between low and high speed as directed by the control board. When the call for heating has ended, the motor will continue to operate on low speed for an additional 30 seconds to extract the residual heat from the warm indoor coil.

When a conventional 2-stage heat pump thermostat calls for the 1st stage of heat, the EcoNet™ Air-Handler Control Board energizes its G/Low terminal and yellow motor speed tap lead with 24VAC which energizes 1st stage air-flow (low speed). The motor will ramp up over a 15 second period and continue operating at 1st stage air-flow (low speed) as long as there is a call for 1st stage heat. The outdoor heat pump unit will automatically ramp up to its intermediate capacity mode after 15 minutes of a 1st stage heat call for the duration of the 1st stage heat call, but the indoor air-flow will remain at 1st stage air-flow (low speed). If thermostat calls for 2nd stage heat, the EcoNet™ Air-Handler Control Board energizes its SPD terminal and blue motor speed tap lead with 24VAC which energizes 2nd stage air-flow (high speed) and the outdoor unit will ramp to its maximum capacity mode. As the thermostat cycles between the 1st and 2nd stages of heat, the motor will cycle between low and high speed as directed by the control board and the heat pump outdoor unit will cycle between its intermediate and maximum capacity modes. When the call for heating has ended, the motor will continue to operate on low speed for an additional 30 seconds to extract the residual heat from the warm indoor coil.

NOTE: If supplemental electric heat is energized during the heat pump heating mode, the system will already be operating at the maximum heating stage and 2nd stage indoor air-flow. The indoor motor will continue to operate at 2nd stage air-flow as long as supplemental electric heat is energized or there is a call for the maximum heating stage.

4.4.7 HEAT PUMP HEATING MODE: (-)H2V

When wired for EcoNet™ communications, the EcoNet™ Control Center will determine which stage of heating is necessary and will then communicate this information to the EcoNet™ Air-Handler Control Board. The control board will then communicate with the variable speed ECM motor and EcoNet™ enabled outdoor unit to direct the motor to start and operate at either the 1st or 2nd stage cooling air-flow level based on the model data contained in the outdoor unit memory card. Upon a call for 1st stage heating, the EcoNet™ Air-Handler Control Board communicates with the variable speed ECM motor to operate at the 1st stage air-flow level. If the EcoNet™ Control Center calls for 2nd stage heating, the EcoNet™ Air-Handler Control Board will communicate with the motor to ramp up to the 2nd stage air-flow level. As the Control Center cycles between the 1st and 2nd stages, the indoor motor will cycle between the 1st and 2nd stage air-flow levels while the 2-stage outdoor unit cycles between its 1st and 2nd stage capacities.

When the call for heating has ended, the Control Board will direct the motor to operate at the minimum air-flow level for 45 seconds to extract the residual cooling from the cold indoor coil before it directs the motor to stop.

When a conventional 24VAC 2-stage thermostat calls for 1st stage heating, the EcoNet™ Air-Handler Control Board communicates with the variable speed ECM motor to operate at the 1st stage air-flow level set using the heating air-flow and trim DIP switches described in Sections 3.13.5 and 3.13.6. If the thermostat calls for 2nd stage heating, the control board will communicate with the motor to ramp up to the 2nd stage air-flow level. As the 2-stage thermostat cycles between the 1st and 2nd stages, the indoor motor will cycle between the 1st and 2nd stage air-flow levels as directed by the control board while the 2-stage outdoor unit cycles between its 1st and 2nd stage capacities.

When the call for heating has ended, the control board will direct the motor to operate at the minimum air-flow level for 45 seconds to extract the residual heat from the warm indoor coil before it directs the motor to stop.

NOTE: If supplemental electric heat is energized during the heat pump heating mode, the electric heat air-flow setting will override the heat pump heating air-flow setting and the indoor air-flow will go to the CFM selected in the EcoNet™ Control Center, or for 24VAC thermostat applications, the CFM selected by the HTR DIP switches on the airhandler control board. (See Section 3.13.7)

4.4.8 HEAT PUMP HEATING MODE: (-)HMV

When wired for EcoNet™ communications, the EcoNet™ Control Center will determine when heating is necessary and the percentage of capacity required and will then communicate this information to the EcoNet™ Air-Handler Control Board. The control board will then communicate with the variable speed ECM motor and EcoNet™ enabled outdoor unit to direct the motor to start and operate at the appropriate heating air-flow level based on the outdoor unit model and the percentage capacity the outdoor unit is operating at throughout the call for heating. The air-flow level will vary as required. When the call for heating has ended, the control board will direct the motor to operate at the minimum air-flow level for 45 seconds to extract the residual heat from the warm indoor coil before it directs the motor to stop.

When a conventional 24VAC 2-stage heat pump thermostat calls for 1st stage heat, the EcoNet™ Air-Handler Control Board communicates with the variable speed ECM motor to operate at minimum heat pump heating air-flow level set using the heat pump heating air-flow DIP switches described in Section 3.13.5. Since the thermostat energizes the B input on the control board with 24 volts, the control board knows to direct the motor to operate at the heating air-flow levels selected using the PAF DIP switches as described in Section 3.13.3. After 15 minutes of operation at the minimum air-flow level, the control board communicates with the motor to automatically ramp up to intermediate

air-flow and will continue to operate at the intermediate air-flow level as long as the 1st stage call is present. The outdoor heat pump unit will also automatically ramp up to its intermediate capacity after 15 minutes of a continuous 1st stage call for heat. If the thermostat calls for 2nd stage heat, the control board will communicate with the motor to ramp up to the maximum air-flow level and the outdoor unit will ramp up to its maximum capacity. As the 2-stage thermostat cycles between the 1st and 2nd stages, the motor and will cycle between the intermediate and maximum air-flow levels as directed by the control board while the outdoor unit cycles between its intermediate and maximum capacity. When the call for cooling has ended, the control board will direct the motor to operate at the minimum air-flow level for 45 seconds to extract the residual heat from the warm indoor coil before it directs the motor to stop.

NOTE: If supplemental electric heat is energized during the heat pump heating mode, the electric heat air-flow setting will override the heat pump heating air-flow setting and the indoor air-flow will go to the CFM selected in the EcoNet™ Control Center, or for 24VAC thermostat applications, the CFM selected by the HTR DIP switches on the air-handler control board. (See Section 3.13.7)

4.4.9 SUPPLEMENTAL ELECTRIC HEAT DURING DEFROST (HEAT PUMP)

Supplemental electric heat during the defrost cycle is provided during the defrost cycle to prevent cold air from being discharged from the supply registers in the home. For systems wired for EcoNet™ communications, this is automatic and no action is required during installation and set-up. For conventional 24VAC thermostat applications, a wire must be run from the W terminal on the EcoNet™ Control Board on the heat pump outdoor unit to the W1 thermostat pigtail on the air-handler should this feature be desired.

4.4.10 EMERGENCY HEAT (HEAT PUMP)

If the EcoNet™ Control Center or heat pump thermostat is set to the “Emergency Heat” mode, the outdoor unit will be prevented from operating and heat will be supplied solely by the electric heater as described in Sections 4.4.3 and 4.4.4 above. The electric heating elements will be energized anytime there is a call for heat and the compressor and outdoor fan motor will remain off. For 24VAC thermostat applications, a jumper should be added between the W1 and E terminals on the thermostat sub-base so the electric heat control will be transferred to the 1st stage of electric heat. This doesn’t apply for thermostats where the W1 and E are combined into a single terminal.

4.4.11 THERMOSTAT FAN SETTING

If the EcoNet™ Control Center or thermostat FAN setting is adjusted to the AUTO position, the indoor blower motor will only operate when there is a call for cooling or heating. If the setting is adjusted to the ON position, the indoor blower will continue to circulate air when there is no call for cooling or heating. (-)H2T air-handlers will operate at Stage 1 air-flow as set in Section 3.13.2. For (-)H2V and (-)H2V air-handlers controlled with a conventional 24VAC thermostat, 50% of the maximum cooling CFM will be delivered based on the DIP switch settings covered in Section 3.13.3. For (-)H2V and (-)H2V air-handlers controlled by an EcoNet™ Control Center, the continuous fan speed can be adjusted in the Fan Only menu to OFF or one of 5 available speeds. Refer to the EcoNet™ Control Center users guide for details.

4.5 CORRECTING ELECTRIC HEAT KW FOR VOLTAGE

The actual electric heat kW varies with the supply voltage. Use the following formula to correct the heater rated kW at voltages other than rated voltage.

$$\text{Actual kW} = \text{Rated kW} \times (\text{Actual Voltage}^2 / \text{Rated Voltage}^2).$$

4.6 CALCULATING ELECTRIC HEAT CAPACITY IN BTU/HR

Use the following formula to convert heater kW to heating capacity in BTUH.

$$\text{BTUH Capacity} = \text{kW} \times 3412$$

(Where 3412 = BTUH per kW)

4.7 CHECKING INDOOR AIR-FLOW

4.7.1 ESTIMATING CFM USING EXTERNAL STATIC PRESSURE: (-)H2T

A common method of checking indoor is to measure the external static pressure that the air-handler is working against and then referring to the air-flow data in Section 3.13.3. Measuring external static pressure to a high degree of precision in the field is challenging, so keep in mind that the CFM determined by this method is an estimate, but is accurate enough for all practical purposes.

To determine external static pressure, the static pressure should be measured in inches of water column across the air-handler using an incline manometer, digital static pressure meter, or a Magnahelic. The static pressure inside the return plenum should be measured as close to the air-handler as possible and must be measured between any external filter rack and the unit so the pressure drop across the filter is accounted for.

The static pressure inside the supply plenum should be measured at a point about half-way between the air-handler and the first elbow or the end of the plenum. Total external static pressure is the sum of the return and supply plenum static pressures. Even though the return plenum static pressure is a negative pressure, it must be added to the supply plenum static pressure, ignoring the negative sign. The supply and return plenum static pressure tubing can also be connected to both pressure ports of the pressure measuring device which will automatically add the two pressures together.

4.7.2 USING THE ON-BOARD LED TO DETERMINE BLOWER CFM: (-)H2V/(-)HMV ONLY

An LED on the EcoNet™ Air-Handler Control Board flashes to indicate air-flow to the nearest 100 CFM on (-)H2V/(-)HMV air-handlers and is by far the easiest method for approximating the blower CFM. See Section 3.13.9 for details.

4.7.3 ESTIMATING CFM USING ELECTRIC HEAT TEMPERATURE RISE

If the air-handler is equipped with an electric heater, the CFM can be estimated using the air temperature rise across the air-handler with the heater and blower both energized once the unit has run long enough for the temperatures to stabilize. As with determining CFM using external static pressure, the CFM determined by this method is an estimate, but is accurate enough for all practical purposes. Measure the return air temperature as close to the unit as possible and the supply air temperature about half way from the air-handler to the first elbow or end of the supply plenum. Use the following formula to calculate CFM once the temperature rise is determined.

$$\text{CFM} = \text{Heating BTUH} / (\text{Elevation Factor} \times \text{Temp Rise } ^\circ\text{F})$$

Elevation (Feet)	Elevation Factor
Sea Level	1.08
500	0.98
1000	0.96
1500	0.95
2000	0.93
2500	0.91
3000	0.90
3500	0.88
4000	0.86
5000	0.83
6000	0.83
7000	0.77
8000	0.74
9000	0.72
10000	0.69

4.8 CHECKING REFRIGERANT CHARGE

System refrigerant charging should only be performed after the indoor air-flow is confirmed to be correct for the application. Once the air-flow is confirmed, refer to the manufacturer's outdoor unit charging chart and installation manual for the proper charging procedure for the system.

5.0 COMPONENTS & CONTROLS

5.1 ECONET™ AIR-HANDLER CONTROL BOARD

The EcoNet™ Air-Handler Control Board controls the indoor blower motor & electric heat operation based on inputs from the indoor EcoNet™ Control Center or a conventional room thermostat and humidistat. When wired for EcoNet™ communications connected to an EcoNet™ Control Center and an EcoNet™ enabled outdoor unit, the control board automatically configures itself to deliver the correct indoor air-flow profile for the specific outdoor unit connected to the EcoNet™ network as long as the outdoor unit is an approved match for the air-handler. Also, certain operating characteristics can be configured through the EcoNet™ Control Center. Refer to the EcoNet™ Control Center manual for further details on configurable options that are available. If a conventional 24VAC thermostat is used to control the system, the control board can be manually configured using a bank of DIP switches located on the control board. (See Figure 35 and Sections 3.13 and 5.3 for details on DIP switch settings).

The control board is located inside the control box that is attached to the blower housing. The same control board is used on EcoNet™ enabled (-)H2T, (-)H2V and (-)H2V and (-)H2V air-handlers, although some features are not utilized by the (-)H2T air-handler.

The EcoNet™ Air-Handler Control Board has the following features.

- An air-handler **Memory Card** stores information needed for unit operation. Once the system is wired for EcoNet™ communications, this information is available to the EcoNet™ Control Center and EcoNet™ enabled outdoor unit.
- An on-board 3 amp automotive style fuse to protect the control circuit.
- An LED provided on the control board flashes to indicate approximate indoor air-flow in 100 CFM increments on (-)H2V and (-)H2V models.
- An RJ-14 port for use with a diagnostic tool.
- Constant CFM and motor torque outputs for the communicating variable speed ECM motor in (-)H2V and (-)H2V air-handlers.
- Operating outputs for the electronic expansion valve (EXV).
- Inputs for the factory installed vapor line temperature sensor and pressure transducer for control of the electronic expansion valve (EXV).
- Inputs for field installed supply and return air temperature sensors available in accessory kit RXHT-A02.
- When the (-)H2V and (-)H2V air-handler is wired for EcoNet™ communications by connecting to an EcoNet™ Control Center and EcoNet™ enabled outdoor unit, the EcoNet™ Air-Handler Control Board will direct the indoor motor to operate at the correct air-flow for the outdoor unit that is connected to the EcoNet™ network. For variable speed outdoor units, the air-flow level will vary based on the percentage of full capacity the compressor is operating at.
- A bank of 12 DIP switches is provided on the control board for motor CFM changes, to enable on-demand dehumidification (ODD) on (-)H2V and (-)H2V air-handlers, and to adjust the cooling superheat offset and EXV step setting on both (-)H2T and (-)H2V air-handlers. (See Figure 35 and Sections 3.13.4 - 3.13.8 and 5.3.2 - 5.3.4)

NOTE: All of the DIP switches except those used for adjusting the cooling superheat offset and EXV step setting are inactive when (-)H2V air-handlers are operating in the EcoNet™ communication mode, so any air-flow or dehumidification adjustments must be made at the EcoNet™ Control Center. Only the cooling superheat and EXV step DIP switches are active on (-)H2T air-handlers regardless of the type of control system being used.

IMPORTANT: Line voltage electrical power must be disconnected from the air-handler for DIP switch setting changes to take effect. Even if the motor is not operating, the motor will not recognize changes in DIP switch positions until power is removed and then restored to the air-handler.

- When the (-)H2V or (-)H2V air-handlers are being controlled by a conventional 2-stage 24VAC thermostat, the EcoNet™ Air-Handler Control Board will direct the indoor motor to operate at the air-flow levels selected by the air-flow DIP switch settings on the control board. (See Section 3.13.3 – 3.13.3.6)
- When the (-)H2V air-handler is being controlled by a conventional 2-stage 24VAC thermostat, the control board will direct the indoor motor to operate at the 1st stage air-flow level for cooling or heat pump heating operation (Y1). The control board will direct the indoor motor to operate at the 2nd stage air-flow level when a 2nd stage call for cooling or heat pump heating is present.
- When the (-)H2V air-handler is being controlled by a conventional 2-stage 24VAC thermostat, the control board will direct the indoor motor to operate at the minimum air-flow level for the first 15 minutes of a 1st stage call for cooling or heat pump heating operation (Y1) and will then direct the indoor motor to operate at the intermediate air-flow level for the duration of the 1st stage operation. The control board will direct the indoor motor to operate at the maximum air-flow level when a 2nd stage call for cooling or heat pump heating is present.
- EcoNet™ Air-Handler Control Board will direct the indoor motor in (-)H2V and (-)H2V air-handlers to operate at 15% less CFM if cooling mode dehumidification is enabled and dehumidification is being called for by the EcoNet™ Control Center, a dehumidifying thermostat, or humidistat. (See Section 3.13.8)
- A call for electric heat will cause the control board to override the heat pump heating air-flow and will direct the indoor motor to operate at the selected electric heat air-flow level. (See Section 3.13.7)
- A plug on the electric heater kit wiring harness plugs into a 4 pin plug receptacle on the control board to allow control of the electric heater by the control board based on thermostat input.
- The thermostat pigtail wire harnesses connect to 7 and 9-pin connectors on the control board. Wires from the thermostat or EcoNet™ Control Center do not connect directly to the control board, but rather to the pigtails that are routed to the exterior of the air-handler cabinet.
- There is a 45 second off-delay programmed into the control board when an (-)H2V or (-)H2V air-handler has been operating in the cooling or heat pump heating mode.

The off-delay maximizes efficiency by extracting the residual cooling or heating capacity in the coil. An off-delay for (-)H2T air-handlers is not provided since a 30 second off-delay is programmed into the constant torque ECM motor.

- There is a 75 second off-delay is programmed into the control board when an (-)H2V or (-)H2M air-handler has been operating in the electric heat or emergency heat mode. The off-delay allows time for the contacts in the bi-metallic disc type heating sequencer to open which de-energizes the heater elements. The electric heat off-delay programmed into the control board for (-)H2T air-handlers programmed is 45 seconds which is added to the 30 second off-delay programmed into the constant torque ECM motor for a total of 75 seconds.
 - Figure 34 shows the location of the control board components and input/output connections.
 - Figure 35 below indicates the function of the DIP switches, relative location of the DIP switches, and the factory switch positions.
1. Electrical heater connection
 2. 5A fuse
 3. RJ14 connector for service tool
 4. Dip switch (heater [HTR], cooling airflow selection [CAF], heating airflow selection [PAF], trim selection, on demand dehumidification [ODD], EXV selections)

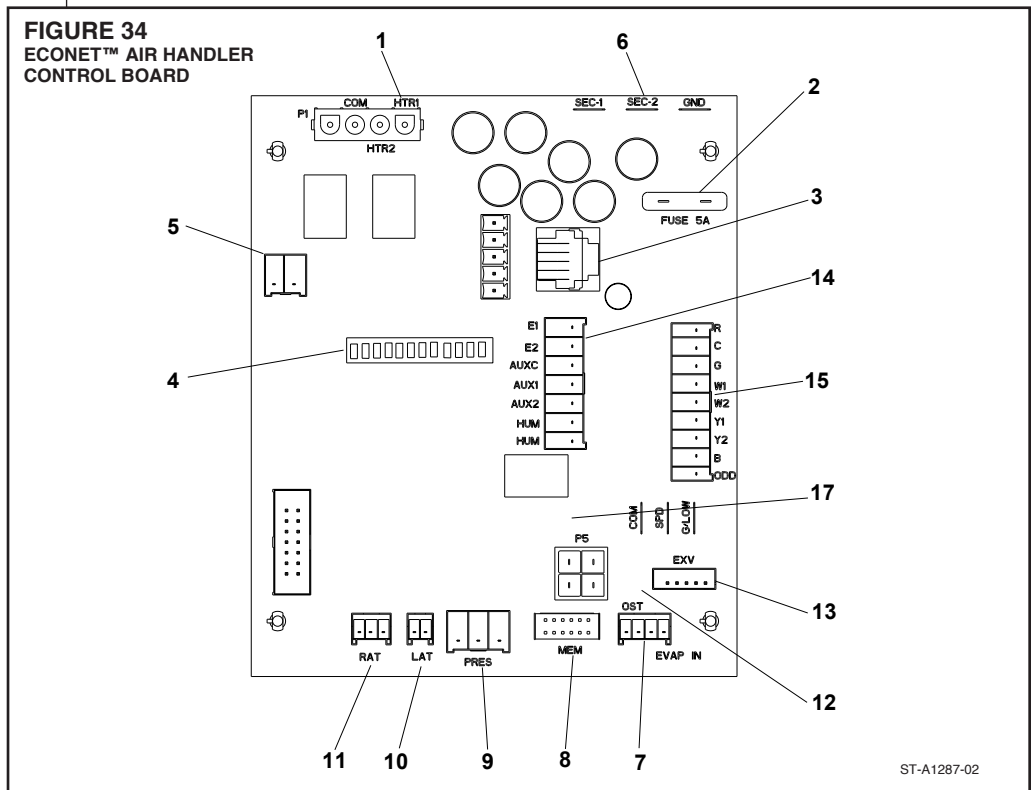

5. 1st stage airflow hold pins (short to hold low stage during ratings test)
6. Power connection (24VAC)
7. Suction and coil thermister connection
8. Model data card
9. Suction pressure transducer
10. Leaving air temperature (LAT) thermister (optional)
11. Return air temperature (RAT) thermister (optional)
12. Electronic expansion valve indicator lights
13. Electronic expansion valve connection
14. Communications and optional harness
15. Thermostat connection (at far right of board).
16. Airflow indicator LED (LED 8)
17. Alert/alarm indicator LED (LED 10)
18. Communication LED 1 and 2

FIGURE 35
DIP SWITCH FUNCTIONS

Switch	Function
HTR (pair)	Electric Heat Air-Flow Settings
CAF (pair)	Cooling Air-Flow Settings
PAF (pair)	Heat Pump Heating Air-Flow Settings
TRIM (pair)	Cooling Air-Flow Trim Adjustment
ODD	On-Demand Dehumidification Selection
SH (pair)	Cooling Superheat Offset Settings
EXV	EXV Step Settings

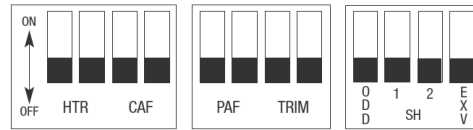

All switches shipped from factory in OFF position as shown

5.2 BLOWER MOTOR

5.2.1 CONSTANT TORQUE ECM MOTOR: (-)H2T

All (-)H2T air-handlers have 5-speed constant torque electronically commutated (ECM) style motors that are significantly more efficient than PSC motors.

- The motor has a control module mounted on the end of the motor opposite the shaft end which is replaceable should only the control module itself fail.
- Constant torque motors do not require a run capacitor.
- A terminal block on the motor shell is provided for the 5 speed taps, labelled T1 – T5. The speed taps are 24VAC inputs. **Do not connect line voltage to these speed taps.** Speed tap selection instructions are detailed in Section 3.13.2.
- All (-)H2T air-handlers are set up to deliver 2 stages of air-flow based as directed by the EcoNet™ Air-Handler Control Board.
- If two or more of the speed tap terminals (T1 – T5) are energized with 24 volts simultaneously, the motor will operate at air-flow programmed for the numerically higher speed tap. An example of this is when both the Y1 and Y2 thermostat inputs are energized for 2nd stage operation. In this case, the motor will ignore the input to the lower speed level (Y1) and operate at 2nd stage air-flow level, assuming the 2nd stage speed tap is correctly connected to a numerically higher speed tap.
- The constant torque motor has a built-in soft start that will ramp the motor up to speed gradually.
- An off-delay is built into the control of the motor that keeps the motor energized for 30 seconds after 24 volts is removed from all speed tap terminals.
- The air-flow delivery rate for a constant torque ECM motor will not decrease as much as it does with a PSC motor.

5.2.2 VARIABLE SPEED ECM BLOWER MOTOR: (-)H2V & (-)HMV

All (-)H2V & (-)HMV models have communicating variable speed electronically commutated (ECM) motors that are significantly more efficient than PSC motors.

- The motor has a control module mounted on the end of the motor opposite the shaft end which is replaceable should only the control module itself fail.
- ECM motors do not require a run capacitor.
- Unlike non-communicating ECM motors, the communication ECM motor operating program does not reside in the motor control itself. The motor operation is controlled by an electronic signal from the EcoNet™ Air-Handler Control Board.
- When (-)H2V & (-)HMV air-handlers are wired for EcoNet™ communications by connecting to an EcoNet™ Control Center and an EcoNet™ enabled outdoor unit, the EcoNet™ Air-Handler Control Board will direct the motor to operate at the correct air-flow for the outdoor unit connected to the EcoNet™ network. For variable speed outdoor units, the air-flow level will vary based on the percentage of full capacity the compressor is operating at.
- When (-)H2V & (-)HMV air-handlers are being controlled by a conventional 2-stage 24VAC thermostat, the EcoNet™ Air-Handler Control Board will direct the motor to operate at the air-flow levels selected by the air-flow DIP switch settings on the control board. (See Section 3.13.3 – 3.13.3.6)
- The EcoNet™ Air-Handler Control Board will direct the motor to operate at 15% less CFM if cooling mode dehumidification is enabled and dehumidification is being called for by the EcoNet™ Control Center, a dehumidifying thermostat, or humidistat.
- The variable speed ECM motor has a built in soft start that will ramp the motor up to speed gradually over a 15 second period.

- There is no off-delay programmed into the motor itself since there is an off-delay built into the EcoNet™ Air-Handler Control Board that keeps the motor energized for 45 seconds after the call for cooling or heat pump heating ends or for 75 seconds after a call for electric heat ends.
- The air-flow delivery rate for the variable speed ECM motor will remain relatively constant regardless of the external static pressure until the motor reaches its torque limit at which time the CFM will begin dropping off as external static pressure continues to increase. The benefit of constant CFM is the assurance of adequate air-flow regardless of the duct system design and loading up of filters as long as the external static pressure remains at a reasonable level and the torque limit of the motor has not been exceeded.

5.3 ELECTRONIC EXPANSION VALVE (EXV)

5.3.1 EXV OVERVIEW

The (-)H2T (EXV models only) and (-)H MV EcoNet™ enabled air handlers are equipped with an electronic refrigerant expansion device otherwise known as an EXV. One of the biggest advantages of an EXV is the control can intelligently change the EXV position based on system demands other than just suction line temperature. By the measurement of the suction pressure via the vapor line pressure transducer (factory installed) and the vapor line thermister (field connected to the vapor line, but factory provided within the air handler) the EcoNet™ enabled air handler control calculates the suction superheat at the indoor coil. This calculation permits the air handler control to make decisions for when to open and close the electronic expansion valve for the purpose of maintaining a predetermined suction superheat. The electronic valve is equipped with a 4-pole removable external stator, and inlet and outlet Chatleff fittings for optimal serviceability. These valves also have an internal check valve to provide heat pump compatibility. When operating in heating mode, the air handler control will open the electronic valve completely to permit the check valve to operate and maximize reverse refrigerant flow.

5.3.2 FACTORY COOLING SUPERHEAT SETTINGS (EXV MODELS)

The memory card on the EcoNet™ Air Handler Control Board is pre-programmed with the optimum cooling mode superheat setting for each air handler. The settings in Table 8 below will be assigned from the factory.

Air Handler Model	Superheat (°F)	DIP Switch Settings	
		1	2
RH2T3621ME	8	OFF	OFF
All Other Models	6	OFF	OFF

5.3.3 COOLING SUPERHEAT OFFSET DIP SWITCHES (EXV MODELS)

Although the factory programmed superheat set point is considered to be the most efficient set point for each air handler, installation conditions can drastically effect the measurement of superheat by the air handler control. For this reason DIP switches have been provided on the EcoNet™ Air-Handler Control Board to make minor adjustments to the superheat.

Table 9 and Figure 36 below show the DIP switch settings for adjusting the superheat.

Superheat Offset Selection Profile	Off Set from Programmed Setting (°F)
A*	0
B	-4
C	-2
D	+2

*Factory setting

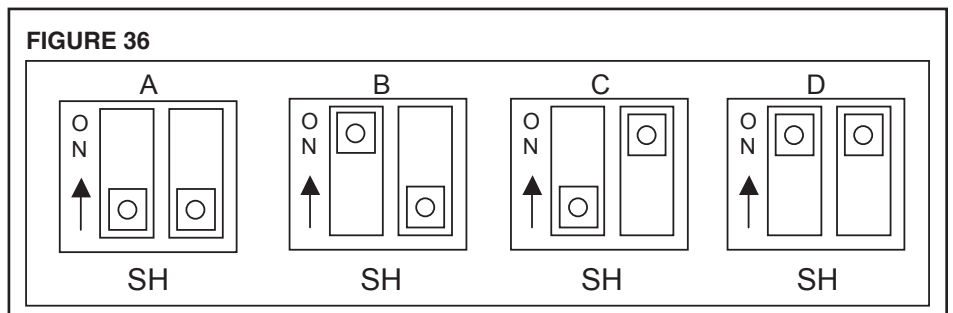

5.3.4 EXV STEP DIP SWITCH SETTINGS

The EXV dip switch has an optional 500 or 1600 steps setting. This dipswitch should always be in the 500 step position (OFF) since only 500 step EXV's are used. The dip-switch makes the control board forward compatible with a 1600 step EXV should one ever be used in the future.

5.3.5 EXV DIAGNOSTIC LED'S

Two LED's are supplied to aid in troubleshooting. The green LED indicates the control is attempting to open the EXV and the amber LED indicates it is attempting to close the EXV. Additionally, it is possible to feel the coil on the EXV pulse when the control is attempting to change the EXV position.

5.4 VAPOR LINE TEMPERATURE SENSOR (THERMISTOR)

The indoor coil in (-)H2T (EXV models only) and (-)H2V air-handlers are equipped with a vapor line thermistor for the purpose of measuring the suction gas temperature during the cooling mode. The measured temperature is compared with the saturated suction temperature and used by the EcoNet™ Air-Handler Control Board to calculate the cooling mode suction superheat and adjust the electronic expansion valve (EXV) position to achieve the optimum cooling mode suction superheat level. The vapor line thermistor is attached to the vapor line with a clip outside the air-handler cabinet after the vapor line is brazed into the vapor line connection stub and then insulated with foam insulation provided in the parts bag included with the air-handler. See Section 3.9 for details on proper attachment of the vapor line thermistor. The thermistor's wiring harness is connected to a mating connector on the EcoNet™ Air-Handler Control Board.

5.5 SUCTION PRESSURE TRANSDUCER

The indoor coil in (-)H2T (EXV models only) and (-)H2V air-handlers are equipped with a suction pressure transducer for the purpose of measuring the suction gas pressure during the cooling mode. The measured pressure is used by the EcoNet™ Air-Handler Control Board to calculate the cooling mode saturated suction temperature required to calculate the suction superheat level using the temperature measured at the vapor line thermistor (See Section 5.4) and adjust the electronic expansion valve (EXV) position to achieve the optimum cooling mode suction superheat level. The suction pressure transducer is attached to a pressure port on the indoor coil suction header. The transducer's wiring harness is connected to a mating connector on the EcoNet™ Air-Handler Control Board.

5.6 THERMAL EXPANSION VALVE (TXV)

The indoor coil on some (-)H2T and (-)H2V models are equipped with a conventional thermal expansion valve (TXV) for refrigerant control. The TXV's are non-bleed and have an internal check valve, making them compatible with AHRI matched 2-stage outdoor heat pumps.

5.7 BLOWER

The blower utilizes a forward curved centrifugal wheel. The blower housing is constructed from galvanized sheet metal. The motor is attached with a 4-arm belly band type mount that screws into the side of the blower housing. The control box attaches to the front of the blower housing for access through the blower access door. The blower slides into place on a track and is secured by 4 sheet metal screws.

5.8 TRANSFORMER

A 40VA transformer is located inside the control box attached to the blower housing which provides 24V control voltage for both the air-handler & the outdoor unit. The transformer in 208/240V models is wired from the factory for 240V applications, but has a separate 208V tap for 208V applications. The black wires connected to the 240V tap must be moved to the 208V tap when installing the air-handler in 208V applications to assure full 24V+ control voltage for reliable operation of the system controls.

5.9 INDOOR COIL ASSEMBLY

- The indoor coil slabs are a fin & tube design with enhanced aluminum fins & internally grooved aluminum tubing.
- Most models have 3 coil slabs in an "N" configuration, but some models have 2 coil slabs in an "A" configuration.

- All (-)H2V air-handlers have electronic expansion valves (EXV) for refrigerant control.
- All (-)H2V air-handlers have non-bleed TXV's.
- (-)H2T air-handlers can have either a non-bleed TXV or an EXV.
- The 10th character in the model number indicates which type of metering device the air-handler is equipped with, "T" for TXV and "E" for EXV. (See Section 2.3 for the model number nomenclature).
- All models have a self-draining polypropylene condensate drain pan to eliminate standing water & a painted & insulated sheet metal drip pan to catch any water drips from the coil when the air-handler is oriented in the horizontal position.
- All models have built-in sheet metal channels in various locations designed to manage condensate when the air-handler is oriented in the horizontal position, thus preventing water "blow-off".
- Copper stubs are provided for field tubing connections.
- The coil assembly slides into the air-handler on sheet metal rails. The coil is installed in the factory for upflow & horizontal left orientations. The coil must be removed and re-installed into the air-handler cabinet 180° from its factory orientation. An additional set of coil support rails must be installed before the coil can be re-installed. The additional set of rails are included with the air-handler for field installation. (See Section 3.2.2)
- The Vapor Line Thermistor or TXV sensing bulb is shipped unattached & must be securely attached to the vapor line with the supplied clip or insulated with the supplied foam insulation.

6.0 ACCESSORIES & KITS

6.1 ELECTRIC RESISTANCE HEATER KITS

- All (-)H2T, (-)H2V & (-)H2V models are shipped without electric resistance heat.
- Electric heat kits ranging from 3kW to 30kW are available for field installation.
- Refer to Sections 3.12.6.1 and 3.12.6.2 for electric heat kit model numbers available for specific air-handler models along with electrical ratings & additional information regarding the heater kits.
- Heater kit installation instructions are provided with the heater kit.
- All heater kits utilize open wire nickel chromium heating elements.
- An automatic reset over-temperature limit is provided to shut off the heater elements should air-flow become too restricted or if the blower motor fails.
- 13kW kits and larger are designed to operate in 2-stage heat mode if so desired or can be operated as single stage if the W1 & W2 thermostat pigtails are wired together.
- 208/240V single-phase ("J" Voltage) and 208/240V 3-phase ("C" Voltage) heater kits are available.
- 208/240V 3-phase ("C" Voltage) heater kits must be installed in "J" Voltage air-handlers since there are no "C" Voltage air-handlers available. "C" voltage heater kits are for 3-phase applications and allow for smaller wire & fuse/breaker size compared to single-phase "J" Voltage heater kits.
- The heater kit is controlled by the blower control based on thermostat inputs.
- All heater kits are available with a circuit breaker style disconnect.
- 10kW heater kits and smaller are also available with either a pull-out style disconnect or with no disconnect.
- Incoming electric power is connected directly to the heater kit power terminals.
- The heater kit is provided with 2 power wires that connect to the air-handler power terminal block, providing power to operate the blower motor and controls.
- The heater kit is also provided with a 4-pin connector that plugs into a mating plug on the blower control to allow the control of the heater based on thermostat inputs.

6.2 JUMPER BAR KITS

- **Jumper Bar Kit 3 Ckt. to 1 Ckt. RXBJ-A31** is used to convert single phase multiple three circuit units to a single supply circuit. Kit includes cover and screw for line side terminals.
- **Jumper Bar Kit 2 Ckt. to 1 Ckt. RXBJ-A21** is used to convert single phase multiple two circuit units to a single supply circuit. Kit includes cover and screw for line side terminals.

NOTE: No jumper bar kit is available to convert three phase multiple two circuit units to a single supply circuit.

6.3 AUXILIARY HORIZONTAL OVERFLOW PANS

Cabinet Size	Auxiliary Horizontal Overflow Pan Accessory Model Number
17.5" wide	RXBM-AC48
21' & 24.5" wide	RXBM-AC61

6.4 EXTERNAL FILTER BASES

Model Cabinet Size	Filter Size	Part Number	A	B
17	16 × 20 [406 × 508]	RXHF-17 Accommodate	15.70	17.50
21	20 × 20 [508 × 508]	RXHF-21 1" or 2" filter	19.20	21.00
24	25 × 20 [635 × 508]	RXHF-24	22.70	25.50

FIGURE 37
EXTERNAL FILTER BASE: RXHF-

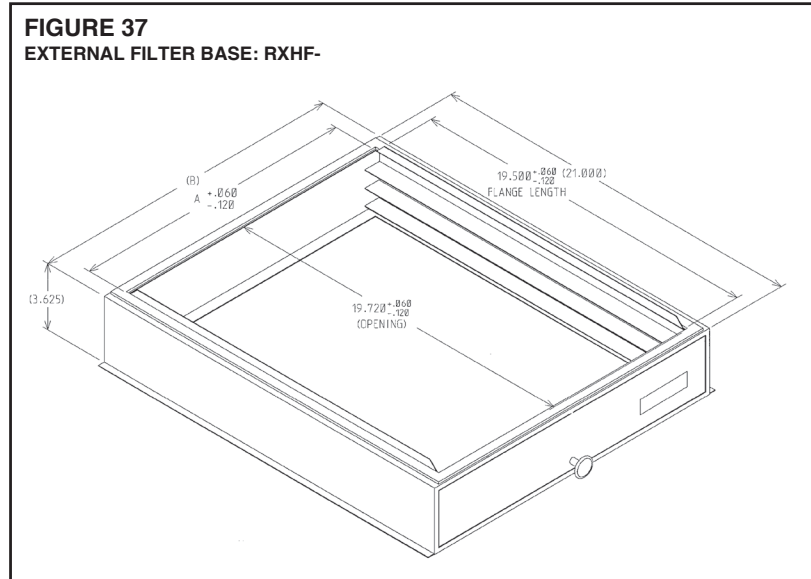

6.5 COMBUSTIBLE FLOOR BASES

For high heat downflow applications. (See Section 3.2.2.)

Model Cabinet Size	Combustible Floor Base Model Number
17	RXHB-17
21	RXHB-21
24	RXHB-24

6.6 HORIZONTAL ADAPTER KITS

This horizontal adapter kit is used to convert RCH replacement coils for horizontal applications if water management parts from original coil are not usable or are unavailable. See the following table to order proper horizontal adapter kit.

RCH Coil Model	Horizontal Adapter Kit Model Number (Single Qty.)	Horizontal Adapter Kit Model Number (10-pak Qty.)
2417S	RXHH-A02	RXHH-A02x10
2421M/3617S	RXHH-A03	RXHH-A03x10
2421H/3621M	RXHH-A04	RXHH-A04x10
6024M	RXHH-A05	RXHH-A05x10
2421U/4821M/6021S	RXHH-A06	RXHH-A06x10

6.7 SUPPLY AND RETURN AIR TEMPERATURE SENSOR KIT

RXHT-A02

7.0 MAINTENANCE

For continuing high performance, and to minimize possible equipment failure, it is essential that periodic maintenance be performed on this equipment. Consult your local dealer as to the proper frequency of maintenance and the availability of a maintenance contract.

IMPORTANT: Before performing any service or maintenance procedures, see the "Safety Information" (Section 1.0) at the front of this manual.

WARNING

Units with circuit breaker(s) meet requirements as a service disconnect switch, however, if access is required to the line side (covered) of the circuit breaker, this side of the breaker(s) will be energized with the breaker(s) de-energized. Contact with the line side can cause electrical shock resulting in personal injury or death.

7.1 AIR FILTER

Check the system filter every ninety days or as often as found to be necessary and if obstructed, clean or replace at once.

A qualified installer, service agency or HVAC professional should instruct the homeowner on how to access filters for regular maintenance.

IMPORTANT: Do not operate the system without a filter in place.

- New filters are available from a local distributor or home supply retailer.

7.2 INDOOR COIL, DRAIN PAN, DRAIN LINE

Inspect the indoor coil, drain pan, and drain line once each year for cleanliness and clean as necessary. Be sure to check the finned surface on the return side of the coil. It may be necessary to remove the air-filter and use a mirror and flashlight to view the return side of the coil.

NOTE: A proper filter is the best defense against a dirty coil. Regardless of the filter choice, proper air flow and velocity also play a crucial role in how effective a filter will be. Most filters will lose their effectiveness when face velocities exceed 300 - 400 feet per minute. Excessive air velocity can allow particles to pass right through the media. Additionally, loaded or restrictive filters may lose their shape in higher air velocity applications and allow unfiltered air to bypass the filter altogether around the sides.

IMPORTANT: Coil and Drainpan Cleaning Method

Clean the finned surface of the indoor coil by rinsing the coil from both sides with clean warm water and/or with a vacuum with a soft brush attachment to remove accumulated contaminants and lint. It is important not to allow the tool to damage or bend the fins. Many chemical cleaners will attack the aluminum tubes which can cause refrigerant leaks. Therefore, use only clean warm water for cleaning aluminum tube evaporator coils. Do not use caustic household drain cleaners or bleach in the condensate pan or near the indoor coil as they will damage the aluminum fins and tubes.

7.3 BLOWER MOTOR AND WHEEL

Inspect the blower motor and wheel for cleanliness. It should be several years before it would become necessary to clean the blower motor and wheel.

- If it becomes necessary to remove the blower assembly from the unit, see instructions on removal and replacement of motor, blower, and blower wheel in Sections 7.5-7.7 below.
- The blower motor and wheel may be cleaned by using a vacuum with a soft brush attachment. Remove grease with a mild solvent such as hot water and detergent. Be careful not to disturb the balance weights (clips) on the blower wheel blades. Do not drop or bend wheel as balance will be affected.

7.4 MOTOR LUBRICATION

The blower motor sleeve bearings are pre-lubricated by the motor manufacturer and do not have oiling ports. Motor should operate for an indefinite period of time without additional lubrication.

7.5 BLOWER ASSEMBLY REMOVAL & REPLACEMENT

Removing the blower assembly is not normally required for normal service and maintenance. Removal is necessary for replacement of defective parts such as motor, blower wheel. After extended use, removal of the blower assembly may become necessary for a thorough cleaning of the blower motor and wheel.

WARNING

If removal of the blower assembly is required, all disconnect switches supplying power to the equipment must be de-energized and locked (if not in sight of unit) so the field power wires can be safely removed from the blower assembly. Failure to do so can cause electrical shock resulting in personal injury or death.

- Mark field power supply wiring (for replacement) attached to terminal block or circuit breaker(s) on blower assembly. Remove wiring from terminal block or circuit breaker(s).
- Mark low voltage control wiring (for replacement) where attached to unit control pig-tails on right side of blower housing. Remove wire nuts attaching field control wiring to unit control pigtails.
- Remove 4 screws holding blower assembly to front channel of cabinet and pull blower assembly from cabinet.
- To replace blower assembly, slide blower assembly into blower deck. Make sure blower assembly engages lances in deck properly. If assembly hangs up, check to make sure top and bottom are lined up in proper locations.
- Slide blower assembly to back of cabinet and make sure it is completely engaged.
- Replace 4 screws holding blower assembly to front channel of cabinet. Take care not to strip screws.
- Replace low voltage control wiring with wire nuts and make sure wiring is per the wiring diagram and all connections are tight and secure.
- Replace field power wiring to terminal block or circuit breaker(s) on control area of blower assembly. Make sure wires are connected per the wiring diagram. Tighten supply power wiring securely to terminal lugs.
- Make sure wiring is within cabinet and will not interfere with access door. Make sure there is proper separation between low voltage control wiring and field power wiring.
- Replace blower assembly control access panel before energizing equipment.

7.6 MOTOR REPLACEMENT

With the blower assembly removed, the indoor blower motor can be removed and replaced using the following procedure:

- Remove motor leads from the motor high and low voltage plugs. Note the lead locations for ease of re-assembly.
- Loosen the set screw holding the blower wheel onto the motor shaft. The shaft extends through the blower hub so that a wrench can be used on the extended shaft to break the shaft loose if necessary. Be careful not to damage the shaft. Use a wheel puller on the groove in the hub if necessary.
- Loosen the bolt holding the wire motor band around the motor shell and pull the motor from the motor mount. Note the motor position in the mount for re-assembly.
- To re-assemble, insert the motor shaft through the hub in the blower wheel and orient the motor to original position.
- For proper motor cooling, it is important that the motor be mounted the same as the original, as far into the blower as practical.
- The dimension from the face of the motor end plate (shaft end) to the edge of the motor mount belly band should be:

DIMENSION	TONNAGE	CABINET SIZE
1 1/2"	2	21
1 1/2"	3	21
2 7/8"	4	24
2 7/8"	5	24

- With motor held to above position and motor lead plugs oriented to the original position (the wire connectors on the motor must point straight to the front of the unit. Securely tighten the bolt on the mount band to the motor shell.
- Turn the motor shaft so that the flat on the shaft is located under blower wheel set-screw, and the blower wheel is centered in the blower housing with the same distance

FIGURE 38
INTERNAL MOTOR PLUG AND SOCKET

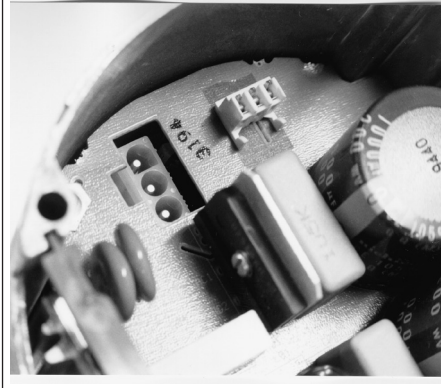

FIGURE 39
ECM MOTOR COMPONENTS

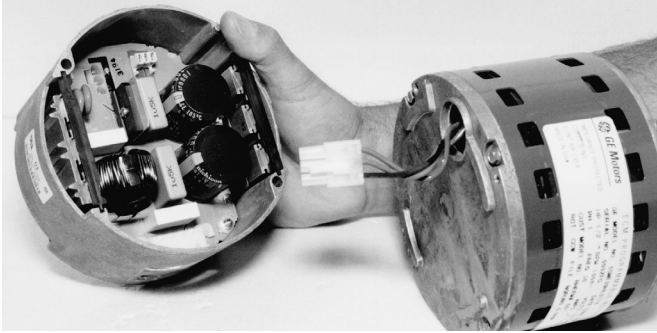
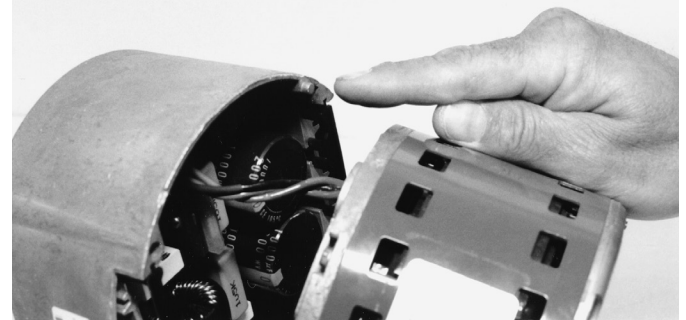

FIGURE 40
MOTOR ALIGNMENT PIN



on each side between the inlet venturi and the outside of the blower wheel.

- Re-assemble the motor wiring (high and low voltage plugs) into the motor.

IMPORTANT: DO NOT FORCE POWER PLUG INTO THE MOTOR CONNECTOR BACKWARDS. The A.C. power plug to the motor has locking tabs. It has been proven that by applying excessive force to the A.C. cable half of the connector it is possible to force the connector in backwards. It will not seat and “click” properly but will make connection. If A.C. power is applied with the connector reversed the motor will be immediately destroyed.

7.7 MOTOR CONTROL MODULE REPLACEMENT

The control module on ECM motors is field serviceable. The motor can be replaced or the motor control can be replaced.

7.8 BLOWER WHEEL REPLACEMENT

With the blower assembly removed and the motor assembly removed (see above instructions), remove the screws holding the blower wrap (cutoff) to the blower sides.

- With wrap (cutoff) screws removed, cut off end of blower wrap will spring up. Lifting wrap blower wheel is removed through the discharge opening in the blower housing.
- To replace, make sure wheel is oriented properly with hub to the opposite side from the motor. Lift blower wrap and insert blower wheel through discharge opening in the blower housing.
- Hold blower wrap down into position and replace screws holding blower wrap to blower sides.
- See motor replacement and blower assembly instructions for remaining assembly procedure.

7.9 ECONET™ AIR HANDLER CONTROL BOARD REPLACEMENT

Verification of the *EcoNet™ Air Handler* control board failure is required before replacement. Access the diagnostic codes using a service tool or access the service menus using the control center (the system must be wired as a serial communicating system to access the service and installer menus using the thermostat). Reference the *EcoNet™ Air Handler Control Board Diagnostic Code Table* (Table 10) in Section 8.2.

WARNING

Disconnect all power to unit before installing or servicing. More than one disconnect switch may be required to de-energize the equipment. Hazardous voltage can cause severe personal injury or death.

NOTE: The memory card is attached to the control box with a tether. The tether has an identification label that can be used to identify the memory card if replacement is needed.

IMPORTANT: Do not cut the tether attached to the memory card when replacing the *EcoNet™ Air Handler Control*. Reinsert the memory card into the replacement *EcoNet™ Air Handler Control*.

FIGURE 41
ECONET™ AIR HANDLER BOARD REPLACEMENT

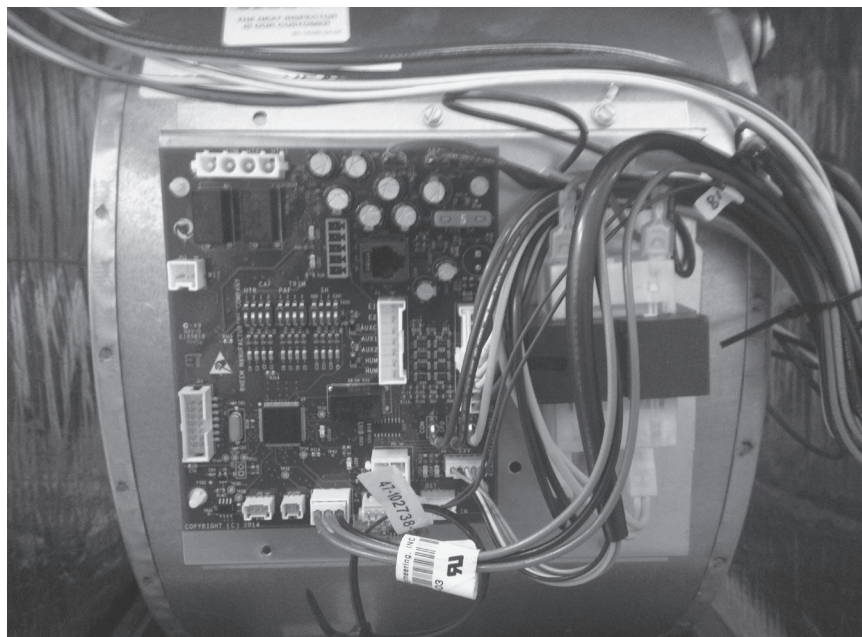

7.10 REPLACEMENT PARTS

Any replacement part used to replace parts originally supplied on equipment must be the same as or an approved alternate to the original part supplied. The manufacturer will not be responsible for replacement parts not designed to physically fit or operate within the design parameters the original parts were selected for.

These parts include but are not limited to: Circuit breakers, heater controls, heater limit controls, heater elements, motor, motor capacitor, blower control, control transformer, blower wheel, indoor coil and sheet metal parts.

When ordering replacement parts, it is necessary to order by part number and include with the order the complete model number and serial number from the unit data plate. (See Parts List for unit component part numbers).

8.0 DIAGNOSTICS

8.1 GENERAL DIAGNOSTICS

Problem	Possible Cause (Suggested Fix)
Blower motor will not operate	<ul style="list-style-type: none"> Failed motor (replace) Failed motor control module (replace module) Blown 3A fuse on blower control (check for control circuit short, replace fuse) Loose wiring connection or broken wire (check connections & wiring) Failed transformer (replace) Failed blower control (replace) Disconnect breaker is turned off or has tripped due to overcurrent or shorted circuit (check for shorts, reset breaker)
Excessive vibration	<ul style="list-style-type: none"> Blower wheel out of balance (replace or clean blower wheel)
Water overflowing drainpan	<ul style="list-style-type: none"> Plugged drain (clear drain) Unit not level (level unit)
Electric heater not heating properly or not heating at all, but blower motor is operating	<ul style="list-style-type: none"> Over temperature limit has tripped (check for low air-flow) Over temperature limit has failed (replace) Sequencer or contactor has failed (replace) One or more heating elements have burned out (replace)
Coil is frozen up	<ul style="list-style-type: none"> System low on refrigerant charge (check for leaks & adjust charge) Dirty return air filter (replace filter) Inadequate air-flow due to incorrect blower motor speed selected (select higher speed) or excessively restrictive duct system (correct duct system)
Excessive air-flow	<ul style="list-style-type: none"> Incorrect blower motor speed selected (select lower speed)
Water blow-off from coil	<ul style="list-style-type: none"> Excessive air-flow (select lower blower motor speed) Contaminants on coil fins (clean coil) Damaged coil fins (comb out fins or replace coil)
TXV or EXV not controlling properly	<ul style="list-style-type: none"> TXV bulb or vapor line thermistor not positioned correctly or clamp not tight (check position of TXV sensing bulb or vapor line thermistor and tightness of clamp) Failed TXV or EXV (replace) Plugged TXV or EXV inlet screen (clean or replace screen or replace TXV or EXV) Bad Electrical connection to suction pressure transducer (check wiring connections) Failed suction pressure transducer (replace transducer) Incorrect DIP switch settings on EXV control (check DIP switch settings) Bad electrical connection to EXV control (check wiring connections) Failed EXV control (replace control)

8.2 ECONET™ AIR-HANDLER CONTROL BOARD DIAGNOSTIC CODES

TABLE 10

ECONET™ AIR HANDLER DIAGNOSTIC CODES

LED Flash Code	Fault Code displayed in Control Center fault recall	Fault	Fault Severity (0=minor, 1=critical)	Status/Possible Cause – Troubleshooting Information
2	A103 or 106	No model data present	1	•Replace memory card with correct system information.
3	A102	Motor size is not correct for model of air handler	1	•Replace the motor with correct horsepower motor. •Replace the memory card with correct system information.
4	A105	Blower fault – Run The ECM motor is running but has a fault	1	• TEST the ECM for proper operation.
4	A104	Motor no run fault – No Run The ECM motor is not operating	1	• Make sure the ECM motor wiring harness is plugged into the ECM motor and control board. •Test the ECM motor for proper operation.
4	A101	Blower motor is not communicating The ECM motor is not communicating to the air handler control board.	1	•Make sure the ECM motor wiring harness is plugged into the ECM motor and control board. •Test the ECM motor proper operation using a service tool.
5	A107	Return sensor out of range The resistance of the sensor out of range for normal operation.	0	•Make sure the sensor is plugged into the air handler control board. • Check the resistance of the sensor. Replace if it is out of tolerance.
6	A108	Leaving air sensor out of range The resistance of the sensor out of range for normal operation.	0	• Make sure the sensor is plugged into the air handler control board.
7	A110	Evaporator thermistor failure		•Check the evaporator thermistor to ensure a proper connection to the control is present. •This occurs only on air handlers not equipped with a low pressure transducer.
8	111	No Valid Suction Temp	1	•Make sure the sensor is plugged into the air handler control board. • Check the resistance of the sensor. Replace if it is out of tolerance.
10	A109	Suction pressure out of range	0	•Check the suction pressure transducer to ensure a proper connection to the control is present. •If operating in heating mode this flash code is normal.
11	111	Control fault The air handler control is not functioning.	1	•Check for proper system operation. • Replace control.

NOTE: Flash codes can be seen on LED10 at the center of the control board.

NOTE: If multiple status codes are active concurrently, the highest priority status code is displayed (the highest priority is actually the lowest blink rate). If a status code is flashing and a new one of higher priority occurs the new status code will flash. The priority is assigned a number where (1) is considered the highest priority. The flash codes will repeat continuously until cleared or overridden by a higher priority code. The operational code information is also passed to the user interface when requested.

9.0 WIRING DIAGRAMS

9.1 WIRING DIAGRAM (-)H2T WITH EXV

WIRING DIAGRAM

SCHEMATIC DIAGRAM

SPEED TAP TABLE		LOW	STATIC	HIGH
TONS	ODU TYPE	Y1	Y2	Y1
2TON	2STG	Y1	T2	T4
2TON	2STG	Y2	T3	T5
2TON	INVERTER	Y1	T1	T1
3TON	INVERTER	Y2	T3	T5
3TON	2STG	Y1	T2	T4
3TON	2STG	Y2	T3	T5
3TON	INVERTER	Y1	T1	T1
4TON	INVERTER	Y2	T3	T5
4TON	2STG	Y1	T2	T4
4TON	2STG	Y2	T3	T5
4TON	INVERTER	Y1	T1	T1
5TON	INVERTER	Y2	T3	T5
5TON	2STG	Y1	T2	T4
5TON	2STG	Y2	T3	T5
5TON	INVERTER	Y1	T1	T1
5TON	INVERTER	Y2	T3	T5

NOTES

- CONNECT SUPPLY WIRING FOR VOLTAGE, PHASE AND HERTZ SHOWN ON RATING PLATE.
- SUPPLY WIRE MUST BE RATED AT 75°C MIN. SEE INSTRUCTIONS FOR SIZE.
- CT FACTORY WIRED FOR 240V. MOVE WIRES FROM 240V TO 208V FOR 208V OPERATION.
- CONTROL WIRING TO THERMOSTAT.
- BLOWER SPEED SELECT(Y1 WIRE Y1) IS FACTORY WIRED TO HIGH SPEED STATIC SPEED TAB T4, AND THE (BL WIRE Y2) IS WIRED TO HIGH STATIC SPEED TAB T5. (SEE SPEED TAP TABLE FOR ALTERNATE CONFIGURATION.
- FOR USE WITH COPPER CONDUCTORS ONLY
- WHEN USING 13KW AND HIGHER IT IS RECOMMENDED TO JUMP W1 AN W2 TOGETHER FOR MAXIMUM TEMPERATURE RISE.

WIRING INFORMATION

LINE VOLTAGE _____

-FACTORY STANDARD _____

-FACTORY OPTION _____

-FIELD INSTALLED _____

LOW VOLTAGE _____

-FACTORY STANDARD _____

-FIELD INSTALLED _____

REPLACEMENT WIRE SIZE AND TYPE _____

-MUST BE THE SAME SIZE AND TYPE _____

-OF INSULATION AS ORIGINAL (105C. MIN.) _____

WARNING _____

-CABINET MUST BE PERMANENTLY GROUNDED _____

-AND CONFORM TO I.E.C., N.E.C., C.E.C., _____

NATIONAL WIRING REGULATIONS, AND LOCAL _____

CODES AS APPLICABLE _____

COMPONENT CODES

CT.....CONTROL TRANSFORMER
 GND.....GROUND
 TB.....TERMINAL BLOCK
 WIRE NUT.....WIRE NUT
 EXV (5 PIN).....ELEC. EX VALVE
 RAT.....RET. AIR TEMP.
 LAT.....LEAVING AIR TEMP.
 EVAP.....COIL TEMP CONN.
 P1.....CJ 1/4 COM TAP
 PRES.....PRESSURE TRANSDUCER
 SPD.....2ND STAGE A.F. TAP
 SEC1.....24V AC
 SEC2.....2ND STAGE OR FAN ONLY A.F. TAP
 G.....COMM POS.
 E1.....COMM. REF.
 E2.....COMM. REF.

WIRE COLOR CODE

BK.....BLACK
 BR.....BROWN
 BL.....BLUE
 PK.....PINK
 G.....GREEN
 GY.....GRAY
 O.....ORANGE
 W.....WHITE
 Y.....YELLOW
 PR.....PURPLE
 R.....RED
 W/BK.....W/WHITE
 Y/BK.....Y/WHITE

ELECTRICAL WIRING DIAGRAM

2 STAGE ECONET
 AIR HANDLER CONTROL
 CONSTANT TORQUE MOTOR

APPROVED: _____
 MODELED: JHB
 CHECKED: _____
 DATE: 10-21-14
 ORIGINAL RELEASE NO: H-1029S000
 PART NO.: 90-101897-07
 REV: 05

9.2 WIRING DIAGRAM (-)H2T WITH TXV

WIRING DIAGRAM

SCHEMATIC DIAGRAM

SPEED TAP TABLE		LOW / STATIC	HIGH
TONS ODUTYPE	Y1 Y2	T2 T3 T4 T5	T1 T2 T3 T4 T5
2TON	Y1 Y2	T2 T3 T4 T5	T1 T1 T1 T1 T1
2TON	Y1 Y2	T2 T3 T4 T5	T1 T1 T1 T1 T1
3TON	Y1 Y2	T2 T3 T4 T5	T1 T1 T1 T1 T1
3TON	Y1 Y2	T2 T3 T4 T5	T1 T1 T1 T1 T1
4TON	Y1 Y2	T2 T3 T4 T5	T1 T1 T1 T1 T1
4TON	Y1 Y2	T2 T3 T4 T5	T1 T1 T1 T1 T1
5TON	Y1 Y2	T2 T3 T4 T5	T1 T1 T1 T1 T1
5TON	Y1 Y2	T2 T3 T4 T5	T1 T1 T1 T1 T1
5TON	Y1 Y2	T2 T3 T4 T5	T1 T1 T1 T1 T1
5TON	Y1 Y2	T2 T3 T4 T5	T1 T1 T1 T1 T1

WIRE COLOR CODE

BK.....BLACK	G.....GREEN	PR.....PURPLE
BR.....BROWN	GY.....GRAY	R.....RED
BL.....BLUE	O.....ORANGE	W.....WHITE
	Y.....YELLOW	

ELECTRICAL WIRING DIAGRAM

2 STAGE ECONET
AIR HANDLER CONTROL
TXV

APPROVED:	CHECKED:	ORIGINAL RELEASE
MOBILED	TEW	NO:
BY:	DATE: 10-06-17	H-1038S000
PART NO.: 90-101897-13		REV: 00

COMPONENT CODES

CT	CONTROL TRANSFORMER
GND	GROUND
IBM	INDOOR BLOWER MOTOR
TB	TERMINAL BLOCK
▲	WIRE NUT
EXV	ELEC. EX VALVE
OST	ELEC. EX THERMISTOR
FAT	RET. AIR TEMP.
CL	LEAVING AIR TEMP.
EXV2	EX VALVE
P11	RJ 14 COM TAP
P5	COMM MTR. CONNECT
PRESS	PRESSURE TRANSDUCER
SEC-2	2ND STAGE A.F. TAP
SEC-1	2ND AC COMM.
G	1ST STAGE OR FAN ONLY A.F. TAP
E1	COMM. POS.
E2	COMM. REF.

NOTES

- CONNECT SUPPLY WIRING FOR VOLTAGE, PHASE, AND HERTZ SHOWN ON RATING PLATE.
- SUPPLY WIRE MUST BE RATED AT 75°C MIN. SEE INSTRUCTIONS FOR SIZE.
- CT FACTORY WIRED FOR 240V. MOVE WIRES FROM 240V TO 208V OPERATION.
- CONTROL WIRING TO THERMOSTAT.
- BLOWER SPEED SELECT (YL WIRE Y1) IS FACTORY WIRED TO HIGH SPEED STATIC SPEED TAB T4, AND THE (BL WIRE Y2) IS WIRED TO HIGH STATIC SPEED TAB T5. (SEE SPEED TAP TABLE FOR ALTERNATE CONFIGURATION.)
- FOR USE WITH COPPER CONDUCTORS ONLY.
- WHEN USING 18KW AND HIGHER IT IS RECOMMENDED TO JUMP W1 AND W2 TOGETHER FOR MAXIMUM TEMPERATURE RISE.
- THE DOTTED BOX NEAR THE DRAWING NUMBER REPRESENTS A .25 X .25 2D DATA MATRIX. SEE ADS-104669-01 FOR DATA MATRIX SPECS.

WIRING INFORMATION

LINE VOLTAGE _____

-FACTORY STANDARD _____

-FACTORY OPTION _____

-FIELD INSTALLED _____

LOW VOLTAGE _____

-FACTORY STANDARD _____

-FACTORY OPTION _____

-FIELD INSTALLED _____

REPLACEMENT WIRE _____

-MUST BE THE SAME SIZE AND TYPE _____

OF INSULATION AS ORIGINAL (105C. MIN.) _____

WARNING _____

-CABINET MUST BE PERMANENTLY GROUNDED _____

AND CONFORM TO I.E.C., N.E.C., C.E.C., _____

NATIONAL WIRING REGULATIONS, AND LOCAL _____

CODES AS APPLICABLE _____

9.3 WIRING DIAGRAM (-)HMV & (-)H2V

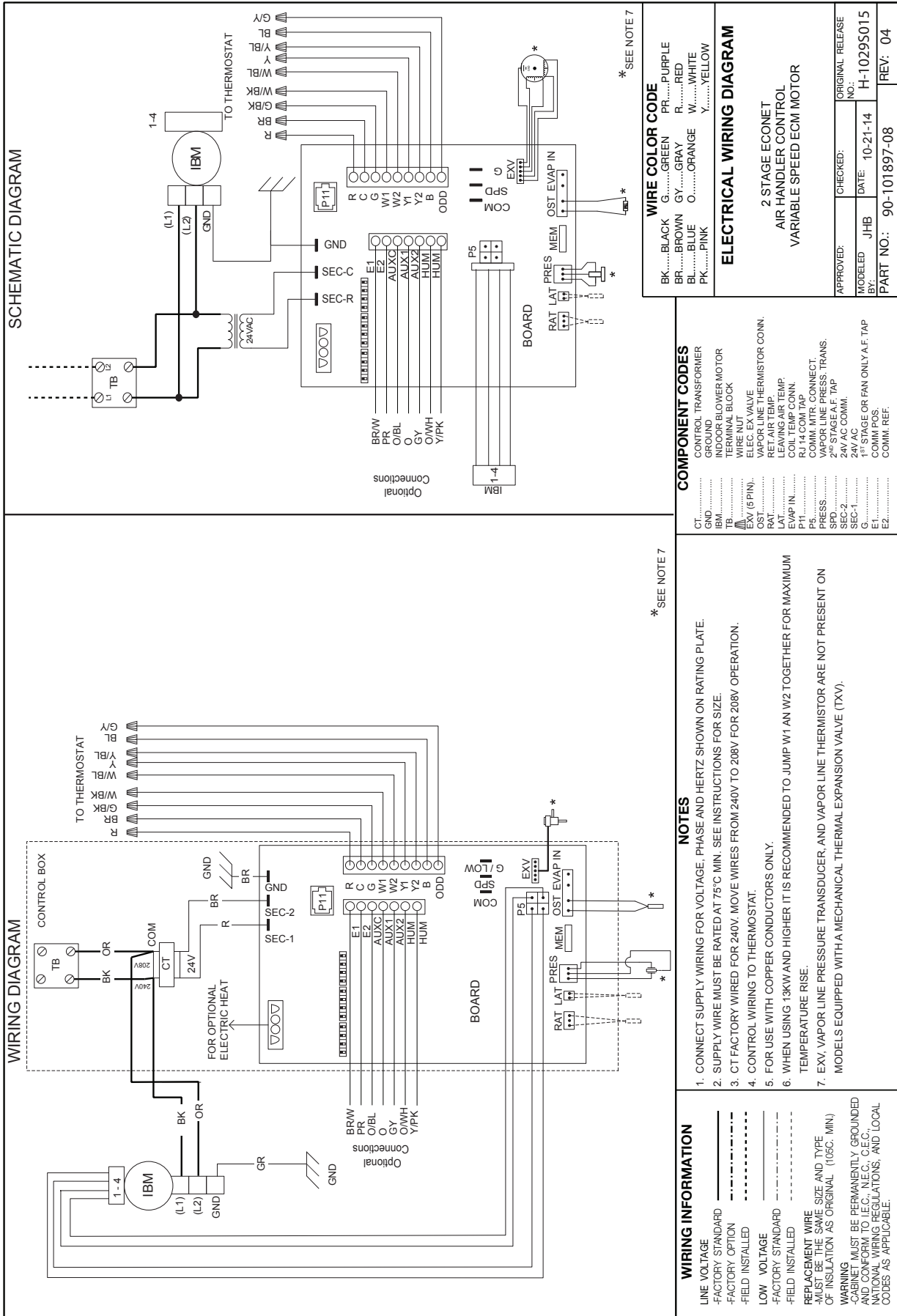

SCHEMATIC DIAGRAM

WIRING DIAGRAM

WIRE COLOR CODE

BK.....BLACK	G.....GREEN	PR.....PURPLE
BR.....BROWN	GY.....GRAY	R.....RED
BL.....BLUE	O.....ORANGE	W.....WHITE
PK.....PINK	Y.....YELLOW	

ELECTRICAL WIRING DIAGRAM

2 STAGE ECONET
AIR HANDLER CONTROL
VARIABLE SPEED ECM MOTOR

APPROVED:	CHECKED:	ORIGINAL RELEASE NO.:
MODELED: JHB	DATE: 10-21-14	H-10295015
BY:		
PART NO.:	90-101897-08	REV: 04

COMPONENT CODES

CT.....CONTROL TRANSFORMER	
GND.....GROUND	
IBM.....INDOOR BLOWER MOTOR	
J.....WIRE NUT	
W.....WIRE BLOCK	
EXV (5 PIN).....ELEC. EX VALVE	
OST.....VAPOR LINE THERMISTOR CONN.	
RAT.....RET. AIR TEMP.	
LAT.....LEAVING AIR TEMP.	
EVAP IN.....COIL TEMP CONN.	
P1.....R1 1/4 COM TAP	
P2.....COMM. MTR. CONNECT.	
P3.....PRESS.....TRANS.	
SPD.....24V AC COMM.	
SEC-1.....24V AC	
SEC-2.....1 ST STAGE OR FAN ONLY A.F. TAP	
G.....COMM POS.	
E1.....COMM. REF.	
E2.....	

NOTES

1. CONNECT SUPPLY WIRING FOR VOLTAGE, PHASE AND HERTZ SHOWN ON RATING PLATE.
2. SUPPLY WIRE MUST BE RATED AT 75°C MIN. SEE INSTRUCTIONS FOR SIZE.
3. CT FACTORY WIRE FOR 240V. MOVE WIRES FROM 240V TO 208V FOR 208V OPERATION.
4. CONTROL WIRING TO THERMOSTAT.
5. FOR USE WITH COPPER CONDUCTORS ONLY.
6. WHEN USING 13KW AND HIGHER IT IS RECOMMENDED TO JUMP W1 AN W2 TOGETHER FOR MAXIMUM TEMPERATURE RISE.
7. EXV, VAPOR LINE PRESSURE TRANSDUCER, AND VAPOR LINE THERMISTOR ARE NOT PRESENT ON MODELS EQUIPPED WITH A MECHANICAL THERMAL EXPANSION VALVE (TXV).

WIRING INFORMATION

LINE VOLTAGE	STANDARD
FACTORY STANDARD	-----
FACTORY OPTION	- - - - -
FIELD INSTALLED
LOW VOLTAGE	-----
FACTORY STANDARD	-----
FIELD INSTALLED

REPLACEMENT WIRE
-MUST BE THE SAME SIZE AND TYPE
-MUST BE PERMANENTLY GROUNDED
-AND CONFORM TO I.E.C., N.E.C., C.E.C.,
NATIONAL WIRING REGULATIONS, AND LOCAL
CODES AS APPLICABLE.

WARNING
-CABINET MUST BE PERMANENTLY GROUNDED
-AND CONFORM TO I.E.C., N.E.C., C.E.C.,
NATIONAL WIRING REGULATIONS, AND LOCAL
CODES AS APPLICABLE.

* SEE NOTE 7

* SEE NOTE 7

