

INSTALLATION INSTRUCTIONS

AIR HANDLERS

FEATURING INDUSTRY STANDARD R-410A REFRIGERANT: 

(-)H1V Premium Efficiency Single Stage with Aluminum Coil

(-)H2V Premium Efficiency Two Stage with Aluminum Coil

(Non-Communicating)



RECOGNIZE THIS SYMBOL AS AN INDICATION OF IMPORTANT SAFETY INFORMATION!

WARNING

These instructions are intended as an aid to qualified licensed service personnel for proper installation, adjustment and operation of this unit. Read these instructions thoroughly before attempting installation or operation. Failure to follow these instructions may result in improper installation, adjustment, service or maintenance possibly resulting in fire, electrical shock, property damage, personal injury or death.



ISO 9001:2008

Certificate Number: 30164

DO NOT DESTROY THIS MANUAL

PLEASE READ CAREFULLY AND KEEP IN A SAFE PLACE FOR FUTURE REFERENCE BY A SERVICEMAN



TABLE OF CONTENTS

1.0 SAFETY INFORMATION	4
2.0 GENERAL INFORMATION	6
2.1 Important Information About Efficiency & Indoor Air Quality.....	6
2.2 Checking Product Received.....	7
2.3 Model Number Nomenclature.....	7
2.4 Available Models.....	7
2.5 Dimensions & Weights.....	8
2.6 Importance of Proper Indoor/Outdoor Match-Ups.....	9
2.7 Importance of a Quality Installation.....	10
3.0 INSTALLATION	10
3.1 Tools & Refrigerant.....	10
3.1.1 Tools Required for Installing & Servicing R-410A Models.....	10
3.1.2 Specifications of R-410A.....	10
3.1.3 Quick Reference Guide for R-410A.....	10
3.2 Applications and Orientation.....	11
3.2.1 Vertical Upflow & Horizontal Left Discharge.....	11
3.2.2 Vertical Downflow & Horizontal Right Discharge.....	11
3.2.3 Installation in an Unconditioned Space.....	13
3.2.4 Installation in Mobile/Manufactured Homes.....	14
3.2.5 Installation in Corrosive Environments.....	15
3.2.6 Supporting Air-Handler in Horizontal Applications.....	15
3.3 Auxiliary Overflow Pan.....	15
3.4 Clearances.....	15
3.5 Duct Flanges.....	15
3.6 Ductwork.....	16
3.7 Return Air Filter.....	17
3.8 Refrigerant Line Connections & Charging.....	18
3.8.1 Preparation.....	18
3.8.2 Liquid Line Filter Drier.....	18
3.8.3 Brazing.....	18
3.8.4 Leak Testing.....	18
3.8.5 Evacuation.....	18
3.8.6 Refrigerant Charging.....	19
3.9 TXV Sensing Bulb Attachment.....	19
3.10 Condensate Drain.....	19
3.11 Thermostat.....	20
3.12 Electrical Wiring.....	21
3.12.1 Configuring Unit for 208 Volt Power.....	21
3.12.2 Grounding.....	21
3.12.3 Power Wiring.....	21
3.12.4 Copper Wire Size.....	22
3.12.5 Electrical Data – Blower Motor Only Without Electric Heat.....	22
3.12.5.1 (-)H1V.....	22
3.12.5.2 (-)H2V.....	22
3.12.6 Electrical Data – With Electric Heat.....	23
3.12.6.1 (-)H1V.....	23
3.12.6.2 (-)H2V.....	25
3.12.7 Electric Heater Kit Supplemental Information.....	26
3.12.8 Control Wiring.....	27
3.12.9 Thermostat & Control Wiring Connections.....	27
3.12.9.1 (-)H1V.....	27
3.12.9.2 (-)H2V.....	28

TABLE OF CONTENTS (continued)

3.13	Air-Flow	29
3.13.1	General Air-Flow Operating Limits	30
3.13.2	ECM Motor Interface Control Board Overview	30
3.13.3	Cooling/Heat Pump Heating Air-Flow Settings.....	31
3.13.4	Electric Heat Air-Flow Settings	32
3.13.5	Air-Flow Trim Adjustment	33
3.13.6	Motor Off-Delay & Soft Start/Stop.....	33
3.13.7	Cooling Mode Enhanced Dehumidification Overview.....	33
3.13.8	Passive Dehumidification Settings	34
3.13.9	Active (On-Demand) Dehumidification Settings	34
3.13.10	Using the On-Board LED to Determine Blower CFM	35
4.0	START-UP.....	36
4.1	Pre-Start Checklist.....	36
4.2	System Start-Up and Operational Check-Out.....	36
4.3	Sequence of Operation	36
4.3.1	Cooling Mode	36
4.3.2	Electric Heat Mode.....	37
4.3.3	Heat Pump Heating Mode.....	37
4.3.4	Supplemental Electric Heat During Defrost.....	37
4.3.5	Emergency Heat (Heat Pump)	37
4.3.6	Thermostat Fan Setting	38
4.4	Correcting Electric Heat kW for Voltage.....	38
4.5	Calculating Electric Heat Capacity in BTU/Hr	38
4.6	Checking Indoor Air-Flow	38
4.6.1	Using the On-Board LED to Determine Blower CFM	38
4.6.2	Estimating CFM Using Electric Heat Temperature Rise.....	38
4.7	Checking Refrigerant Charge	38
5.0	COMPONENTS & CONTROLS	39
5.1	ECM Motor Interface Control Board	39
5.2	Variable Speed ECM Blower Motor	39
5.3	Blower	39
5.4	Transformer	40
5.5	Indoor Coil Assembly	40
6.0	ACCESSORIES & KITS	40
6.1	Electric Resistance Heater Kits.....	40
6.2	Jumper Bar Kits	41
6.3	Auxiliary Horizontal Overflow Pans.....	41
6.4	External Filter Bases	41
6.5	Combustible Floor Bases.....	41
6.6	Horizontal Adapter Kits.....	41
7.0	MAINTENANCE	42
7.1	Air-Filter	42
7.2	Indoor Coil, Drain Pan, Drain Line	42
7.3	Blower Motor & Wheel.....	42
7.4	Motor Lubrication	42
7.5	Blower Assembly Removal & Replacement	42
7.6	ECM Motor Replacement.....	43
7.7	ECM Motor Control Module Replacement	43
7.8	Blower Wheel Replacement	45
7.9	Replacement Parts	45
8.0	DIAGNOSTICS.....	46
9.0	WIRING DIAGRAM	47

▲ WARNING (SEE SECTION 3.12: ELECTRICAL WIRING)

Disconnect all power to unit before installing or servicing. More than one disconnect switch may be required to de-energize the equipment. Hazardous voltage can cause severe personal injury or death.

▲ WARNING (SEE SECTION 7.5: BLOWER ASSEMBLY REMOVAL & REPLACEMENT)

If removal of the blower assembly is required, all disconnect switches supplying power to the equipment must be de-energized and locked (if not in sight of unit) so the field power wires can be safely removed from the blower assembly. Failure to do so can cause electrical shock resulting in personal injury or death.

▲ WARNING

Because of possible damage to equipment or personal injury, installation, service, and maintenance should be performed by a trained, qualified service personnel. Consumer service is recommended only for filter cleaning/replacement. Never operate the unit with the access panels removed.

1.0 SAFETY INFORMATION

▲ WARNING

Duct leaks can create an unbalanced system and draw pollutants such as dirt, dust, fumes and odors into the home causing property damage. Fumes and odors from toxic, volatile or flammable chemicals, as well as automobile exhaust and carbon monoxide (CO), can be drawn into the living space through leaking ducts and unbalanced duct systems causing personal injury or death (see Figure 1).

- If air-moving equipment or ductwork is located in garages or off-garage storage areas - all joints, seams, and openings in the equipment and duct must be sealed to limit the migration of toxic fumes and odors including carbon monoxide from migrating into the living space.
- If air-moving equipment or ductwork is located in spaces containing fuel burning appliances such as water heaters or boilers - all joints, seams, and openings in the equipment and duct must also be sealed to prevent depressurization of the space and possible migration of combustion byproducts including carbon monoxide into the living space.

▲ WARNING

These instructions are intended as an aid to qualified, licensed service personnel for proper installation, adjustment and operation of this unit. Read these instructions thoroughly before attempting installation or operation. Failure to follow these instructions may result in improper installation, adjustment, service or maintenance possibly resulting in fire, electrical shock, property damage, personal injury or death.

▲ WARNING (SEE SECTION 3.2.2: VERTICAL DOWNFLOW)

The RXHB-17, RXHB-21 or RXHB-24 combustible floor base is required when some units with electric heat are applied downflow on combustible flooring. Failure to use the base can cause a fire resulting in property damage, personal injury or death. See **CLEARANCES** for units requiring a combustible floor base. See the accessory section in this manual for combustible floor base RXHB.

▲ WARNING (SEE SECTION 3.13.2: GROUNDING)

The unit must be permanently grounded. Failure to do so can result in electrical shock causing personal injury or death.

▲ WARNING (SEE SECTION 7.0: MAINTENANCE)

Units with circuit breaker(s) meet requirements as a service disconnect switch, however, if access is required to the line side (covered) of the circuit breaker, this side of the breaker(s) will be energized with the breaker(s) de-energized. Contact with the line side can cause electrical shock resulting in personal injury or death.

▲ WARNING (SEE SECTION 3.6: DUCTWORK)

Do not, under any circumstances, connect return ductwork to any other heat producing device such as fireplace insert, stove, etc. Unauthorized use of such devices may result in fire, carbon monoxide poisoning, explosion, personal injury or property damage.

Continued on next page >

WARNING

PROPOSITION 65: This appliance contains fiberglass insulation. Respirable particles of fiberglass are known to the State of California to cause cancer.

All manufacturer products meet current Federal OSHA Guidelines for safety. California Proposition 65 warnings are required for certain products, which are not covered by the OSHA standards.

California's Proposition 65 requires warnings for products sold in California that contain or produce any of over 600 listed chemicals known to the State of California to cause cancer or birth defects such as fiberglass insulation, lead in brass, and combustion products from natural gas.

All "new equipment" shipped for sale in California will have labels stating that the product contains and/or produces Proposition 65 chemicals. Although we have not changed our processes, having the same label on all our products facilitates manufacturing and shipping. We cannot always know "when, or if" products will be sold in the California market.

You may receive inquiries from customers about chemicals found in, or produced by, some of our heating and air-conditioning equipment, or found in natural gas used with some of our products. Listed below are those chemicals and substances commonly associated with similar equipment in our industry and other manufacturers.

- Glass Wool (Fiberglass) Insulation
- Carbon Monoxide (CO).
- Formaldehyde
- Benzene

More details are available at the websites for OSHA (Occupational Safety and Health Administration), at www.osha.gov and the State of California's OEHHA (Office of Environmental Health Hazard Assessment), at www.oehha.org. Consumer education is important since the chemicals and substances on the list are found in our daily lives. Most consumers are aware that products present safety and health risks, when improperly used, handled and maintained.

WARNING (SEE SECTION 3.7: AIR FILTER)

Do not operate the system without filters. A portion of the dust entrained in the air may temporarily lodge in the duct runs and at the supply registers. Any circulated dust particles could be heated and charred by contact with the heating elements. This residue could soil ceilings, walls, drapes, carpets and other articles in the house.

Soot damage may occur even with filters in place when certain types of candles, oil lamps or standing pilots are burned.

WARNING

The first 36 inches of supply air plenum and ductwork must be constructed of sheet metal as required by NFPA 90B. The supply air plenum or duct must have a solid sheet metal bottom directly under the unit with no openings, registers or flexible air ducts located in it. If flexible supply air ducts are used they may be located only in the vertical walls of a rectangular plenum, a minimum of 6 inches from the solid bottom. Metal plenum or duct may be connected to the combustible floor base, if not, it must be connected to the unit supply duct flanges such that combustible floor or other combustible material is not exposed to the supply air opening from the downflow unit. Exposing combustible (non-metal) material to the supply opening of a downflow unit can cause a fire resulting in property damage, personal injury or death.

Exceptions to downflow warnings:

- Installations on concrete floor slab with supply air plenum and ductwork completely encased in not less than 2 inches of concrete (See NFPA 90B).

CAUTION (SEE SECTION 3.2.2: VERTICAL DOWNFLOW & HORIZONTAL RIGHT DISCHARGE)

Unit must be reconfigured for vertical down or horizontal right supply air discharge applications. The coil must be repositioned so the vertical drainpan is on the bottom for vertical down discharge applications or the horizontal drip pan is below coil for horizontal right discharge applications. Failure to reconfigure the unit for these applications can result in property damage and poor system performance.

CAUTION (SEE SECTION 3.3: AUXILIARY OVERFLOW PAN)

In compliance with recognized codes, an auxiliary drain pan must be installed under all equipment containing evaporator coils that are located in any area of a structure where damage to the building or building contents may occur as a result of an overflow of the coil drain pan or a stoppage in the primary condensate drain piping. See Section 6.3 of this manual for auxiliary horizontal overflow pan accessory information (model RXBM).

NOTICE

When used in cooling applications, excessive sweating may occur when unit is installed in an unconditioned space. This can result in property damage.

NOTICE

Improper installation, or installation not made in accordance with the Underwriters Laboratory (UL) certification or these instructions, can result in unsatisfactory operation and/or dangerous conditions and are not covered by the unit warranty.

CAUTION (SEE SECTION 7.7: ECM CONTROL MODULE REPLACEMENT)

Reversing the 5-pin connector on the ECM motor causes immediate failure of the control module.

⚠ NOTICE

Use of this air-handler during construction is not recommended. If operation during construction is absolutely required, the following temporary installation requirements must be followed:

Installation must comply with all Installation Instructions in this manual including the following items:

- Properly sized power supply and circuit breaker/fuse
- Air-handler operating under thermostatic control;
- Return air duct sealed to the air-handler;
- Air filters must be in place;
- Correct air-flow setting for application
- Removing the coil and storing it in a clean safe place is highly recommended until construction is completed and the outdoor unit is installed.
- Clean air-handler, duct work, and components including coil upon completion of the construction process and verify proper air-handler operating conditions according as stated in this instruction manual.
- NOTE: Electric strip heater elements tend to emit a burning odor for a few days if dust has accumulated during construction. Heater elements are easily damaged. Take great care when cleaning them. Low pressure compressed air is recommended for cleaning elements.

2.0 GENERAL INFORMATION

2.1 IMPORTANT INFORMATION ABOUT EFFICIENCY & INDOOR AIR QUALITY

Central cooling and heating equipment is only as efficient as the duct system that carries the cooled or heated air. To maintain efficiency, comfort and good indoor air quality,

FIGURE 1
MIGRATION OF DANGEROUS SUBSTANCES, FUMES, AND ODORS INTO LIVING SPACES

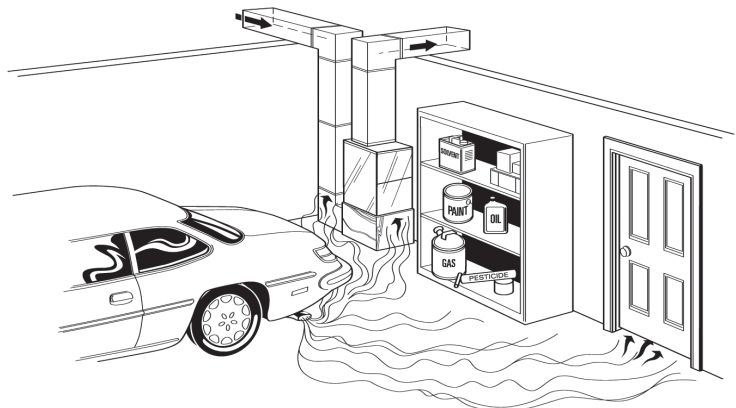

Adapted from *Residential Duct Diagnostics and Repair*, with permission of Air Conditioning Contractors of America (ACCA).

⚠ WARNING



Carbon Monoxide (CO) Poisoning Can Cause Severe Injury or Death.

Carbon Monoxide from the exhaust of motor vehicles and other fuel burning devices can be drawn into the living space by the operation of the central heating and air conditioning system.

Exhaust from motor vehicles, generators, garden tractors, mowers, portable heaters, charcoal and gas grills, gasoline powered tools, and outdoor camping equipment contains carbon monoxide, a poisonous gas that can kill you. You cannot see it, smell it, or taste it.

- Do NOT operate an automobile or any engine in a garage for more than the few seconds it takes to enter or exit the garage.
- Do NOT operate any fuel-burning device in an enclosed or partly enclosed space, or near building windows, doors or air intakes.

The U.S. Consumer Product Safety Commission (CPSC) and Health Canada recommend the installation of UL or CSA certified Carbon Monoxide Alarm(s) in every home.

⚠ WARNING

Duct leaks can create an unbalanced system and draw pollutants such as dirt, dust, fumes and odors into the home causing property damage. Fumes and odors from toxic, volatile or flammable chemicals, as well as automobile exhaust and carbon monoxide (CO), can be drawn into the living space through leaking ducts and unbalanced duct systems causing personal injury or death (see Figure 1).

- If air-moving equipment or ductwork is located in garages or off-garage storage areas - all joints, seams, and openings in the equipment and duct must be sealed to limit the migration of toxic fumes and odors including carbon monoxide from migrating into the living space.
- If air-moving equipment or ductwork is located in spaces containing fuel burning appliances such as water heaters or boilers - all joints, seams, and openings in the equipment and duct must also be sealed to prevent depressurization of the space and possible migration of combustion byproducts including carbon monoxide into the living space.

⚠ NOTICE

Improper installation, or installation not made in accordance with the Underwriters Laboratory (UL) certification or these instructions, can result in unsatisfactory operation and/or dangerous conditions and are not covered by the unit warranty.

it is important to have the proper balance between the air being supplied to each room and the air returning to the cooling and heating equipment.

Proper balance and sealing of the duct system improves the efficiency of the heating and air conditioning system and improves the indoor air quality of the home by reducing the amount of airborne pollutants that enter homes from spaces where the ductwork and/or equipment is located. The manufacturer and the U.S. Environmental Protection Agency's Energy Star Program recommend that central duct systems be checked by a qualified contractor for proper balance and sealing.

▲ NOTICE

In compliance with recognized codes, an auxiliary drain pan must be installed under all equipment containing evaporator coils that are located in any area of a structure where damage to the building or building contents may occur as a result of an overflow of the coil drain pan or a stoppage in the primary condensate drain piping. See accessories section of this manual for auxiliary horizontal overflow pan information (model RXBM).

2.2 CHECKING PRODUCT RECEIVED

Immediately upon receipt, all cartons and contents should be inspected for transit damage. Units with damaged cartons should be opened immediately. If damage is found, it should be noted on the delivery documents and a damage claim filed with the delivering carrier.

2.3 MODEL NUMBER NOMENCLATURE

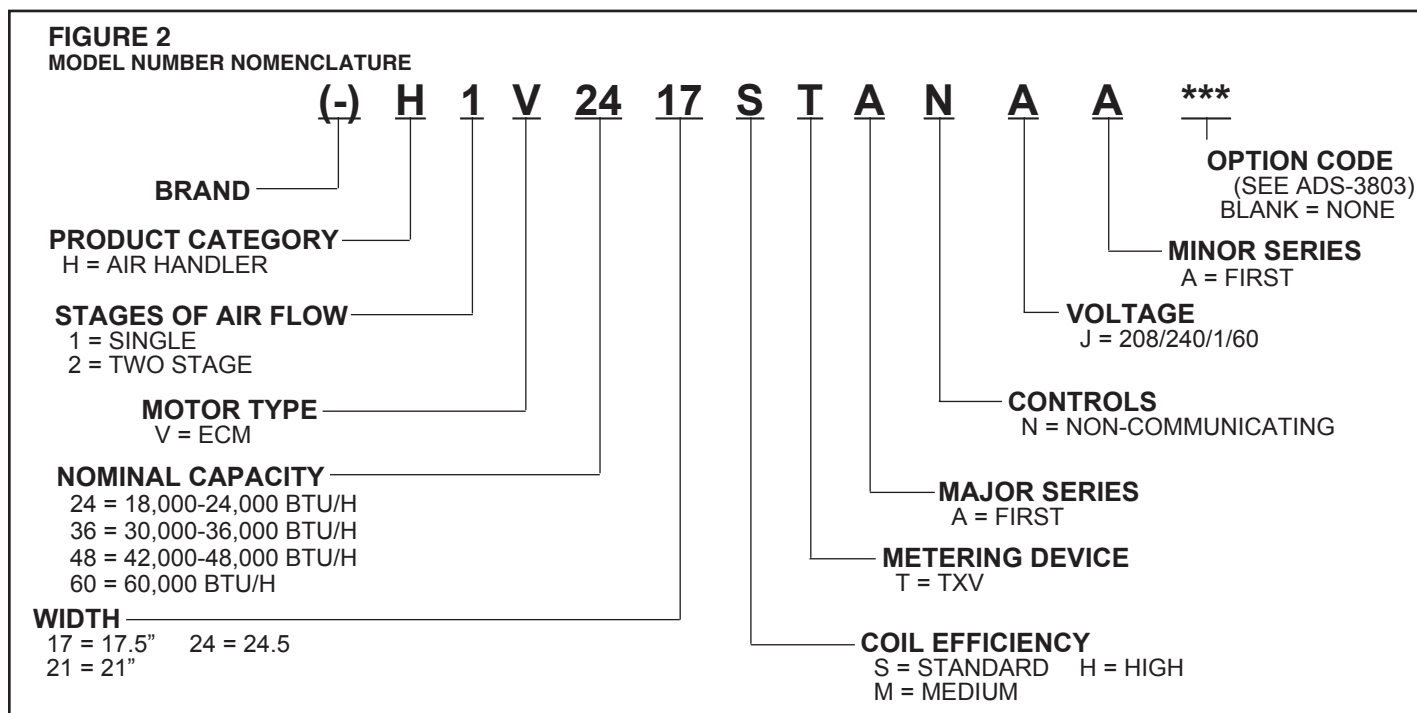

2.4 AVAILABLE MODELS

AVAILABLE MODELS
RH1V2417STANJA
RH1V3617STANJA
RH1V3621MTANJA
RH1V3621HTANJA
RH1V4821STANJA
RH1V4821MTANJA
RH1V4824STANJA
RH1V6021STANJA
RH1V6024STANJA

AVAILABLE MODELS
RH2V2421MTANJA
RH2V3621MTANJA
RH2V4821MTANJA
RH2V6024STANJA
RH2V2417STANJA

2.5 DIMENSIONS & WEIGHTS

FIGURE 3
DIMENSIONS AND WEIGHTS

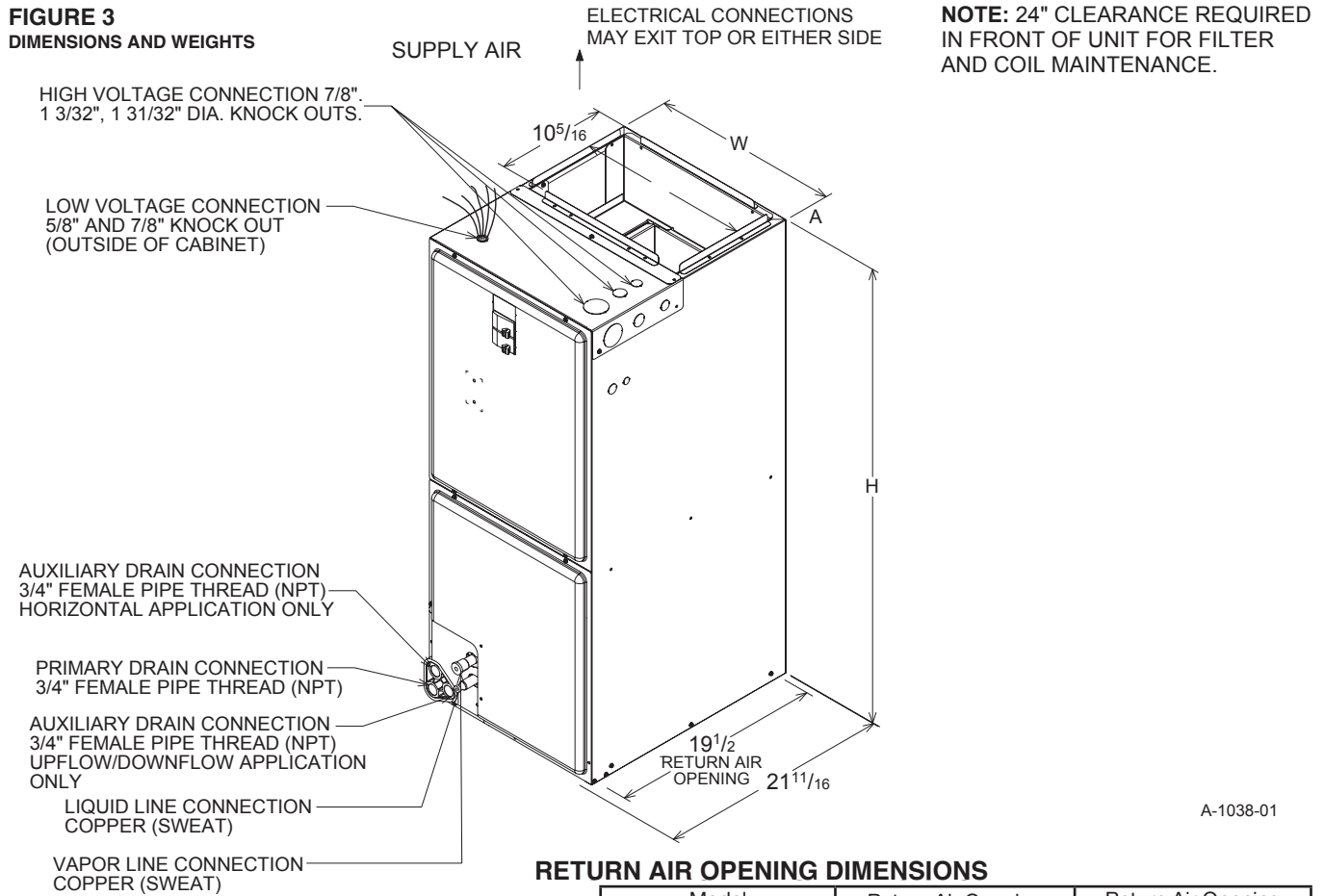

A-1038-01

UPFLOW UNIT SHOWN;
UNIT MAY BE INSTALLED UPFLOW, DOWNFLOW,
HORIZONTAL RIGHT, OR LEFT AIR SUPPLY.

RETURN AIR OPENING DIMENSIONS

Model Cabinet Size	Return Air Opening Width (Inches)	Return Air Opening Depth/Length (Inches)
17	15 7/8	19 3/4
21	19 3/8	19 3/4
24	22 7/8	19 3/4

DIMENSIONAL DATA

MODEL SIZE (-)H1V	UNIT WIDTH "W" IN. [mm]	UNIT HEIGHT IN. [mm]	SUPPLY DUCT "A" IN. [mm]	NOMINAL CFM [L/s]		UNIT WEIGHT / SHIPPING WEIGHT (LBS.) [kg] UNIT WITH COIL (MAX. KW.)
				LO	HI	
2417ST	17 ¹ / ₂ " [445]	42 ¹ / ₂ " [1080]	16" [409]	600 [283]	800 [378]	82/96 [37/44]
3617ST	17 ¹ / ₂ " [445]	42 ¹ / ₂ " [1080]	16" [409]	1000 [472]	1200 [566]	90/104 [41/47]
3621HT	21" [533]	57" [1448]	19 ¹ / ₂ " [495]	1000 [472]	1200 [566]	135/147 [61/67]
3621MT	21" [533]	50 ¹ / ₂ " [1282]	19 ¹ / ₂ " [495]	1000 [472]	1200 [566]	126/142 [57/64]
4821MT	21" [533]	57" [1448]	19 ¹ / ₂ " [495]	1400 [661]	1600 [755]	141/153 [64/69]
4821ST	21" [533]	50 ¹ / ₂ " [1282]	19 ¹ / ₂ " [495]	1400 [661]	1600 [755]	130/146 [59/66]
4824ST	24 ¹ / ₂ " [622]	50 ¹ / ₂ " [1282]	23" [585]	1600 [755]	1800 [850]	142/160 [64/72]
6021ST	21" [533]	57" [1448]	19 ¹ / ₂ " [495]	1600 [755]	1700 [802]	136/148 [62/67]
6024ST	24 ¹ / ₂ " [622]	55 ¹ / ₂ " [1410]	23" [585]	1600 [755]	1800 [850]	162/179 [73/81]

MODEL SIZE (-)H2V	REFRIGERANT CONNECTIONS		UNIT HEIGHT IN. [mm]	UNIT WIDTH "W" IN. [mm]	SUPPLY DUCT "A" IN. [mm]	NOMINAL CFM [L/s]				UNIT WEIGHT / SHIPPING WEIGHT (LBS.) [kg] UNIT WITH COIL (MAX. KW.)
	SWEAT (IN.) [mm] ID					1 st STAGE		2 nd STAGE		
	LIQUID	VAPOR				ODD*	Normal	ODD*	Normal	
2421MT	3/8" [9.53]	3/4" [19.05]	21" [533]	42 ¹ / ₂ " [1080]	19 ¹ / ₂ " [495]	600 [283]	630 [297]	800 [378]	825 [389]	99/117 [45/51]
3621MT	3/8" [9.53]	3/4" [19.05]	21" [533]	50 ¹ / ₂ " [1282]	19 ¹ / ₂ " [495]	800 [378]	825 [389]	1180 [557]	1200 [566]	135/147 [61/67]
4821MT	3/8" [9.53]	7/8" [19.05]	21" [533]	57" [1448]	19 ¹ / ₂ " [495]	1200 [566]	1230 [580]	1600 [755]	1635 [771]	141/153 [64/69]
6024ST	3/8" [9.53]	7/8" [19.05]	24 ¹ / ₂ "	55 ¹ / ₂ " [1410]	23" [584]	1330 [627]	1350 [637]	1700 [802]	1730 [816]	159/176 [72/80]
2417ST	3/8" [9.53]	3/4" [19.05]	17 ¹ / ₂ " [445]	42 ¹ / ₂ " [1080]	16" [409]	600 [283]	630 [297]	800 [378]	825 [389]	82/96 [37/44]

2.6 IMPORTANCE OF PROPER INDOOR/OUTDOOR MATCH-UPS

To assure many years of reliable operation and optimum customer comfort and to assure the outdoor unit warranty remains valid, an air-handler model should be selected that is properly matched to the outdoor unit. This is especially critical for heat pump systems to assure proper refrigerant charge balance between the cooling and heating modes. The recommended approach is to select an air-handler model that has an AHRI match with the outdoor unit. Refer to the AHRI directory at www.ahridirectory.org to confirm the air-handler and outdoor unit are a certified combination in the AHRI Directory.

2.7 IMPORTANCE OF QUALITY INSTALLATION

A quality installation is critical to assure safety, reliability, comfort, and customer satisfaction. Strict adherence to applicable codes, the information in this installation manual, the outdoor unit installation manual, and the thermostat installation manual are key to a quality installation. Read the entire instruction manuals before starting the installation.

IMPORTANT: This product has been designed and manufactured to meet certified AHRI capacity and efficiency ratings with the appropriate outdoor units. However, proper refrigerant charge, proper airflow, and refrigerant line sizing are critical to achieve optimum capacity and efficiency and to assure reliable operation. Installation of this product should follow the manufacturer's refrigerant charging and airflow instructions located in the outdoor unit installation instructions and the charging chart label affixed to the outdoor unit. Failure to confirm proper charge and airflow may reduce energy efficiency and shorten equipment life.

The equipment has been evaluated in accordance with the Code of Federal Regulations, Chapter XX, Part 3280.

Install the unit in accordance with applicable national, state, and local codes. Latest editions are available from: "National Fire Protection Association, Inc., Batterymarch Park, Quincy, MA 02269." These publications are:

- ANSI/NFPA No. 70-(Latest Edition) National Electrical Code.
- NFPA90A Installation of Air Conditioning and Ventilating Systems.
- NFPA90B Installation of warm air heating and air conditioning systems.

Install the unit in such a way as to allow necessary access to the coil/filter rack and blower/control compartment.

3.0 INSTALLATION

3.1 TOOLS & REFRIGERANT

3.1.1 TOOLS REQUIRED FOR INSTALLING AND SERVICING R-410A MODELS

Manifold Sets:

- Up to 800 PSIG High-Side
- Up to 250 PSIG Low-Side
- 550 PSIG Low-Side Retard

Manifold Hoses:

- Service Pressure Rating of 800 PSIG

Recovery Cylinders:

- 400 PSIG Pressure Rating
- Dept. of Transportation 4BA400 or BW400

NOTICE

R-410A systems operate at higher pressures than R-22 systems. Do not use R-22 service equipment or components on R-410A equipment.

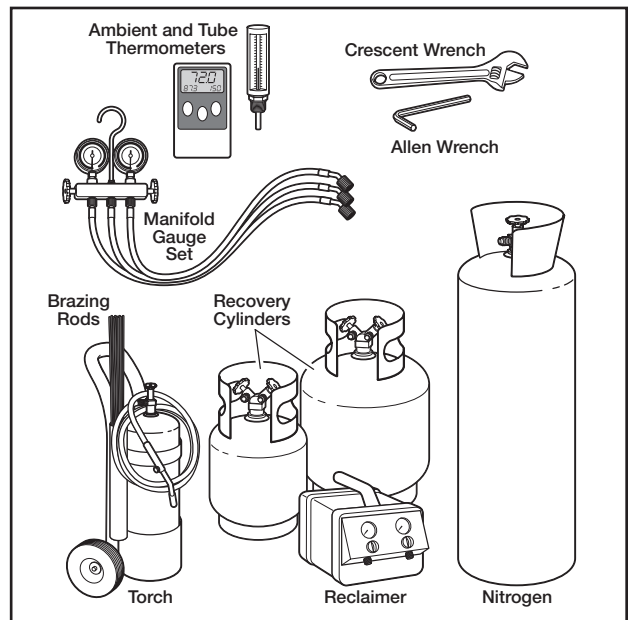

3.1.2 SPECIFICATIONS OF R-410A

Application: R-410A is not a drop-in replacement for R-22. Equipment designs must accommodate its higher pressures. It cannot be retrofitted into R-22 heat pumps.

Physical Properties: R-410A has an atmospheric boiling point of -62.9°F [-52.7°C] and its saturation pressure at 77°F [25°C] is 224.5 psig.

Composition: R-410A is a near-azeotropic mixture of 50% by weight difluoromethane (HFC-32) and 50% by weight pentafluoroethane (HFC-125).

Pressure: The pressure of R-410A is approximately 60% (1.6 times) greater than R-22. Recovery and recycle equipment, pumps, hoses, and the like must have design pressure ratings appropriate for R-410A. Manifold sets need to range up to 800 psig high-side and 250 psig low-side with a 550 psig low-side retard. Hoses need to have a service pressure rating of 800 psig. Recovery cylinders need to have a 400 psig service pressure rating, DOT 4BA400 or DOT BW400.

Combustibility: At pressures above 1 atmosphere, a mixture of R-410A and air can become combustible. R-410A and air should never be mixed in tanks or supply lines or be allowed to accumulate in storage tanks. Leak checking should never be done with a mixture of R-410A and air. Leak-checking can be performed safely with nitrogen or a mixture of R-410A and nitrogen.

3.1.3 QUICK-REFERENCE GUIDE FOR R-410A

- R-410A refrigerant operates at approximately 60% higher pressure (1.6 times) than R-22. Ensure that servicing equipment is designed to operate with R-410A.
- R-410A refrigerant cylinders are light rose in color.
- R-410A, as with other HFCs, is only compatible with POE oils.
- Vacuum pumps will not remove moisture from POE oil used in R-410A systems.
- R-410A systems are to be charged with liquid refrigerants. Prior to March 1999, R-410A refrigerant cylinders had a dip tube. These cylinders should be kept upright for equipment charging. Post-March 1999 cylinders do not have a dip tube and should be inverted to ensure liquid charging of the equipment.
- Do not install a suction line filter drier in the liquid line.
- A factory-approved outdoor liquid line filter drier is shipped with every unit and must be installed in the liquid line at the time of installation. If only the air-handler is being replaced on an existing system, the existing filter drier must be replaced at the time of installation with a field supplied filter drier. **IMPORTANT:** A bi-flow filter drier must be used for heat pump applications. Filter driers must be rated for minimum working pressure of 600 psig. The filter drier will only have adequate moisture-holding capacity if the system is properly evacuated.
- Desiccant (drying agent) must be compatible for POE oils and R-410A refrigerant.

3.2 APPLICATIONS AND ORIENTATION

3.2.1 VERTICAL UPFLOW & HORIZONTAL LEFT DISCHARGE

- Vertical Upflow & Horizontal Left Discharge is the factory configuration for all models (see Figure 4).
- The return air plenum must be large enough to supply unit and strong enough to support unit weight.
- If return air is to be ducted through the floor, install duct flush with floor. Use fireproof resilient gasket 1/8 to 1/4 in. thick between duct, unit and floor. Set unit on floor over opening.

IMPORTANT: Do not cut the side out of air-handler cabinet for a side return duct as this will result in the return air bypassing the coil. Instead, install air-handler on top of a field supplied sheet metal or wooden box and run the side return duct into the side of the box.

FIGURE 4
DIMENSIONS FOR REFRIGERANT-TUBING & DRAIN CONNECTIONS

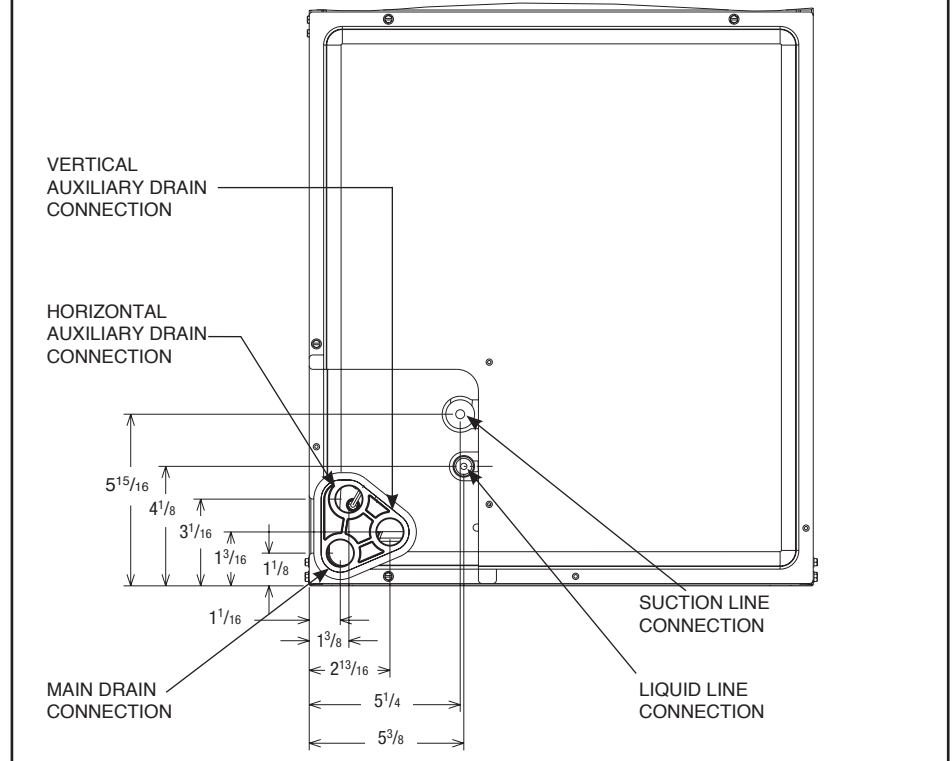

3.2.2 VERTICAL DOWNFLOW & HORIZONTAL RIGHT DISCHARGE

The unit as shipped from the factory is not configured for vertical down or horizontal right discharge applications and must be converted in the field to work in those applications. To make this conversion, remove the coil door and slide the indoor coil out of the cabinet.

When converting the air-handler for vertical down and horizontal right discharge applications, an additional set of 2 coil support rails must be installed before the coil can be reinstalled. These additional rails are supplied with the air-handler and are packaged with the duct flanges. Six screws are also provided for mounting the rails and can be found in the installation hardware bag. Clearance holes must be drilled in the sides of the cabinet for the mounting screws using the provided dimples as guides. Note that the shorter coil support rail with no notch must be mounted on the left-hand side to provide clearance for the drainpan condensate connection boss.

The vertical down/horizontal right coil support rails were not installed at the factory so the insulation under them would not be compressed which could result in exterior cabinet sweating in humid environments due to that location being in the cold downstream side of the indoor coil in vertical up and horizontal left discharge applications. The coil support rails installed at the factory should be left in place to help retain the cabinet insulation. They will be located on the warmer return side of the air-handler for down and horizontal right discharge applications and will therefore not pose a risk for cabinet sweating.

Once the additional coils support rails are installed, slide the coil back into the cabinet 180° from its original position, ensuring the retaining channel is fully engaged with the coil rail. (See Figure 6, Detail A.) Leave the coil door off until after the refrigerant tubing is brazed to the refrigerant stubs to allow TXV to be wrapped with a wet rag or heat sink compound during the brazing process. If the air-handler is not already in position, it can now be positioned so the blower discharge is either down or to the right depending on the application.

FIGURE 5
ROTATING CIRCUIT BREAKER

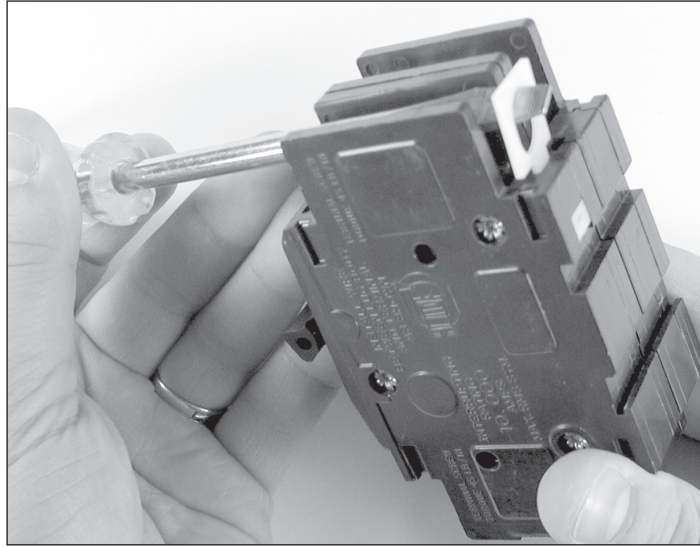

DRIP LOOP NOTE: When installing the unit in down or horizontal right discharge applications, make sure the wires going to the blower motor form a proper drip loop to force any condensate that might form on the wires to drip off the lowest point of the wiring instead of entering the motor or motor control. This may require cutting the wire-tie and installing a new wire-tie to form a new drip loop.

IMPORTANT: To comply with certification agencies and the National Electric Code for down discharge applications, the circuit breaker(s) on field-installed electric heater kits must be re-installed per procedure below so that the breaker switch “on” position and marking is up and the “off” position and marking is down.

- To turn breaker(s): Rotate one breaker pair (circuit) at a time starting with the one on the right. Loosen both lugs on the load side of the breaker. Wires are bundles with wire ties, one bundle going to the right lug and one bundle going to the left lug.
- Using a screwdriver or pencil, lift white plastic tab with hole away from breaker until breaker releases from mounting opening (see Figure 5).
- With breaker held in hand, rotate breaker so that “on” position is up and the “off” position is down with unit in the vertical mounting position. Insert right wire bundle into top right breaker lug, ensuring all strands of all wires are inserted fully into lug, and no wire insulation is caught in lug.
- Tighten lug as tight as possible while holding circuit breaker. Check wires and make sure each wire is secure and none are loose. Repeat for left wire bundle in left top circuit breaker lug.

IMPORTANT: Failure to securely hold the breaker will result in the plastic mounting boss on the breaker to be broken off when the lug is tightened.

- Replace breaker by inserting breaker mounting tab opposite white pull tab in opening, hook mounting tab over edge in opening.
- With screwdriver or pencil, pull white tab with hole away from breaker while setting that side of breaker into opening. When breaker is in place, release tab, locking circuit breaker into location in opening.
- Repeat above operation for remaining breaker(s) (if more than one is provided).
- If one is used, replace the single point wiring jumper bar on line side of breaker and tighten securely.
- Double check wires and lugs to make sure all are secure and tight. Check to make sure unit wiring to circuit breaker load lugs match that shown on the unit wiring diagram.

⚠ WARNING

The RXHB-17, RXHB-21 or RXHB-24 combustible floor base is required when some units with electric heat are applied downflow on combustible flooring. Failure to use the base can cause a fire resulting in property damage, personal injury or death. See CLEARANCES (Section 3.4) for units requiring a combustible floor base. See the accessory section in this manual for combustible floor base RXHB.

IMPORTANT: Units cannot be installed horizontally laying on or suspended from the back of the unit.

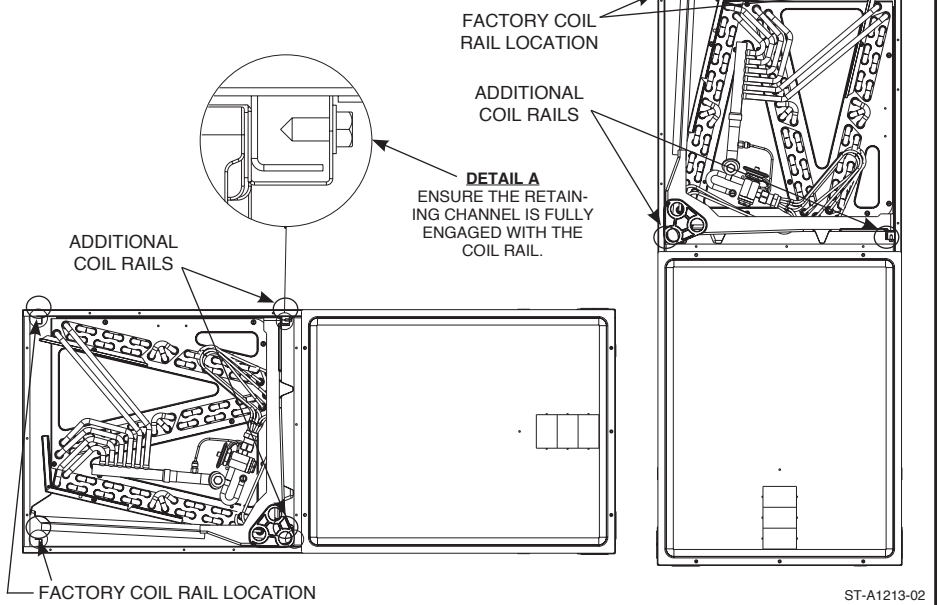
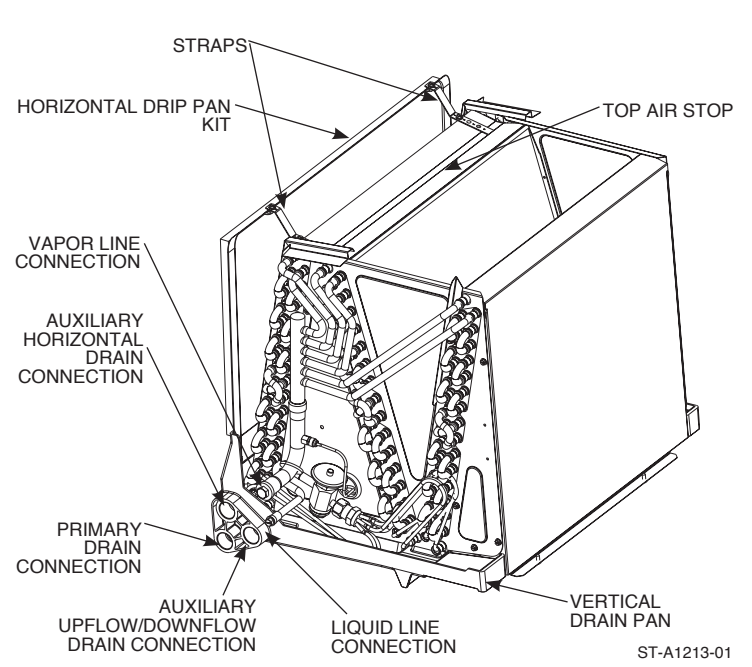
FIGURE 6**VERTICAL DOWNFLOW & HORIZONTAL RIGHT APPLICATIONS****FIGURE 7****INDOOR COIL AND DRAIN PAN DETAILS****CAUTION**

Auxiliary horizontal overflow pan kits RXBM- (or equivalent) are required when the unit is configured for the horizontal position over a finished ceiling and/or living space. (See Sections 3.3 and 6.3.) Failure to install overflow pan can result in property damage.

3.2.3 INSTALLATION IN AN UNCONDITIONED SPACE

The exterior cabinet of an air handler has a greater risk of sweating when installed in an unconditioned space than when it is installed in the conditioned space. This is primarily due to the temperature of the conditioned air moving through the air handler and the air circulating around the unit where it is installed. For this reason, the following is recommended for all air handler applications, but special attention should be paid to those installed in unconditioned spaces:

- Duct sizing and airflow are critical and must be based on the equipment selected.
- Supply and return duct attachment: If other than the factory flanges are used, the attachment of ducting must be insulated and tight to prevent sweating.

- No perimeter supply flanges are provided. If a full perimeter supply duct is used, it is the responsibility of the installer to provide duct flanges as needed, to secure and seal the supply duct to prevent air leakage and the sweating that will result.
- Apply caulking around all cabinet penetrations such as power wires, control wires, refrigerant tubing and condensate line where they enter the cabinet. Seal the power wires on the inside where they exit conduit opening. Sealing is required to prevent air leakage into the unit which can result in condensate forming inside the unit, control box, and on electrical controls. Take care not to damage, remove or compress insulation when applying the caulk.
- In some cases, the entire air handler can be wrapped with insulation. This can be done as long as the unit is completely enclosed in insulation, sealed and service access is provided to prevent accumulation of moisture inside the insulation wrap.
- An auxiliary overflow pan is recommended to protect the structure from excessive cabinet sweating or a restricted coil drain line. (See Section 3.3)
- If an electric heater kit is installed, be sure the breaker or disconnect cover is sealed tightly to the door panel.

3.2.4 INSTALLATION IN MOBILE/MANUFACTURED HOMES

1. Air handler must be secured to the structure using "L" brackets or pipe strap.
2. Allow a minimum of 24 inches (610 mm) front clearance required to access doors.
3. Recommended method for securing air handler:
 - A. If air handler is against the wall, secure top of air handler to wall stud using two 16ga thick angle brackets one on each side. Attach brackets with No. 10 self-tapping $\frac{1}{2}$ " long screws to air handler and use $\frac{5}{16}$ " lag screws $1\frac{1}{2}$ " long to wall stud. Secure bottom of unit with two 16ga "L" brackets with No. 10 self-tapping $\frac{1}{2}$ " long screws to air handler and use $\frac{5}{16}$ " lag screws $1\frac{1}{2}$ " long to floor.
 - B. If air handler is away from wall attach pipe strap to top of air handler using No. 10 $\frac{1}{2}$ " long self-tapping screws on both sides. Angle strap down and away from back of air handler, remove all slack, and fasten to wall stud of structure using $\frac{5}{16}$ " lag screws $1\frac{1}{2}$ " long. Secure bottom of unit with two 16ga "L" brackets with No. 10 self-tapping screws to air handler and use $\frac{5}{16}$ " lag screws $1\frac{1}{2}$ " long to floor.

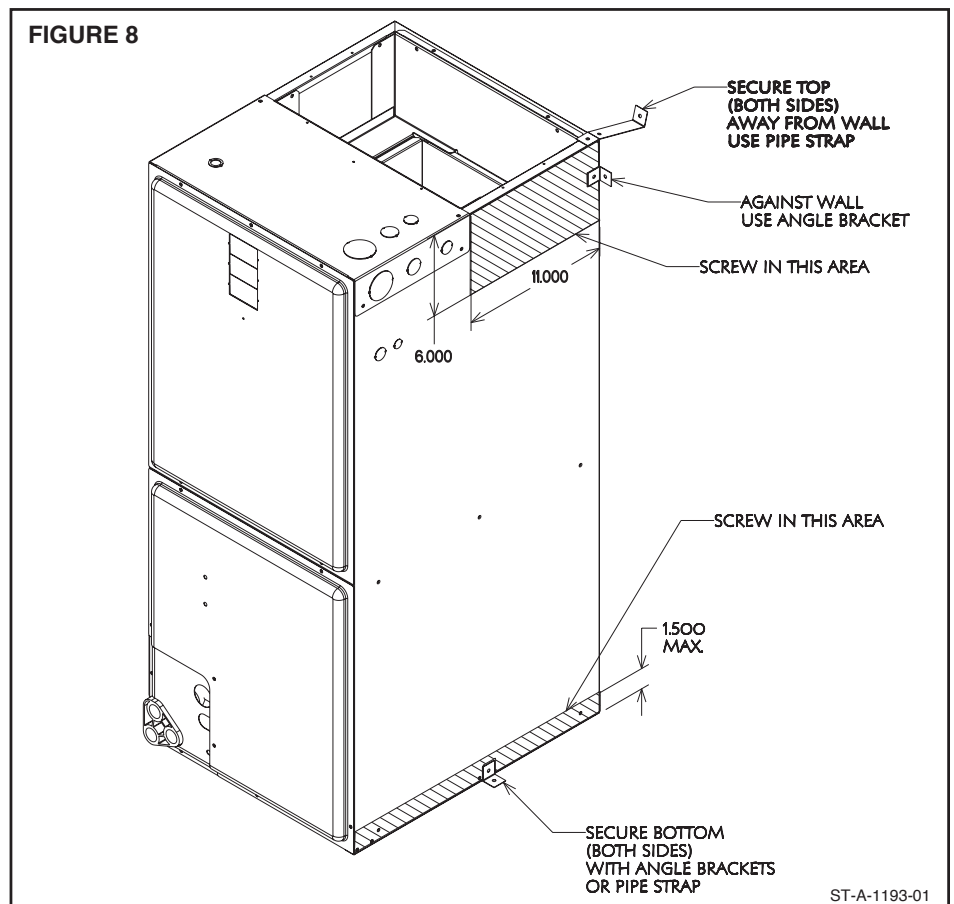

3.2.5 INSTALLATION IN CORROSIVE ENVIRONMENTS

The metal parts of this unit may be subject to rust or deterioration if exposed to a corrosive environment which can shorten its life. In addition to exposure to the exterior of the cabinet, chemical contaminants inside the building that can be drawn into the unit from the return air grille and attack structural metal parts, electrical components and the

indoor coil, causing premature failure of the unit. If the unit is to be installed in an area where contaminants are likely to be a problem, special attention should be given to isolate the unit and return grille from contaminants.

3.2.6 SUPPORTING AIR-HANDLER IN HORIZONTAL APPLICATIONS

The air-handler must be adequately supported underneath if it is installed in the horizontal position to prevent it from sagging in the middle which can cause issues removing and re-installing the access panels. Position the unit on adequate supports or on support angles or channels (See Figure 9) before connecting ductwork to the unit. If an auxiliary overflow pan is required (See Section 3.3), the overflow pan will need to be adequately supported with the air-handler being supported underneath within the auxiliary overflow pan by angles and/or channels.

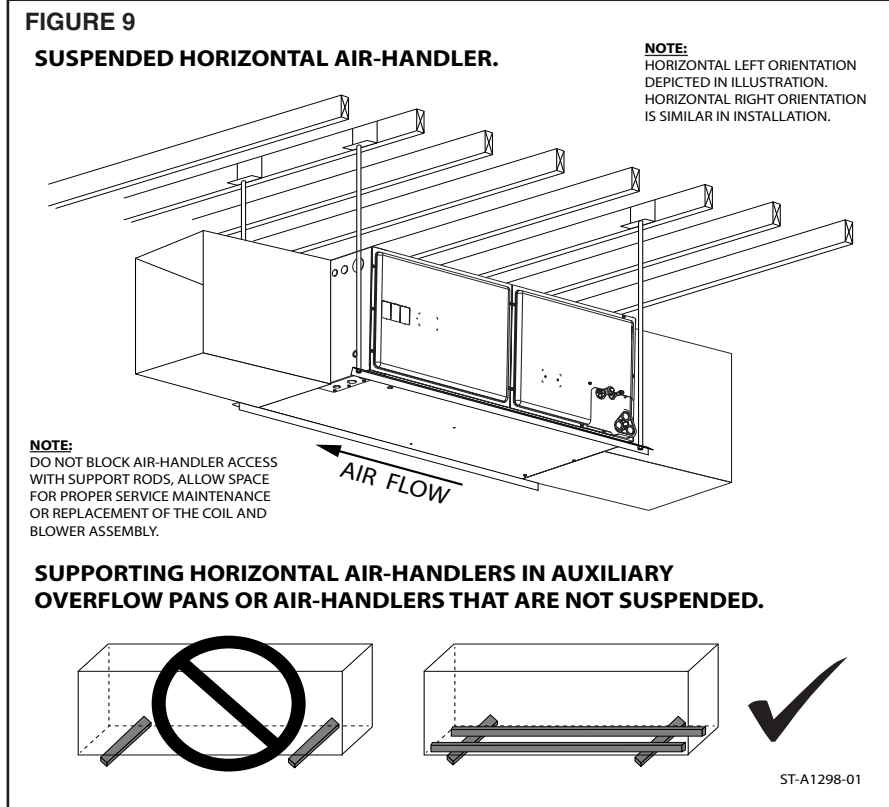

3.3 AUXILIARY OVERFLOW PAN

In compliance with recognized codes, an auxiliary overflow pan must be installed under all equipment containing evaporator coils that are located in any area of a structure where damage to the building or building contents may occur as a result of an overflow of the coil drain pan or a stoppage in the primary condensate drain piping. See Section 6.3 of this manual for information regarding the recommended auxiliary horizontal overflow pan (model RXBM) for this air-handle.

3.4 CLEARANCES

- All units are designed for “0” inches clearance to combustible material on all cabinet surfaces except for downflow application with higher kW electric heat as noted below.
- Some units require a combustible floor base depending on the heating kW if installed in the downflow configuration on a combustible surface. The following table should be used to determine these requirements.

Model Cabinet Size	17	21	24
Maximum Model Designation kW	15	18	20

- Units with electric heating kW equal to or less than the values listed in the table do not require a combustible floor base. See Section 6.5 for Combustible Floor Base RXHB-XX.
- Units with electric heat require a one inch clearance to combustible material for the first three feet of supply plenum and ductwork.
- Vertical downflow applications require clearance on at least one side of the unit for electrical connections. Refrigerant and condensate drain connections are made on the front of the unit.
- All units require 24 inches minimum access to the front of the unit for service.
- These units may be installed in either ventilated or nonventilated spaces.

3.5 DUCT FLANGES

Duct flanges (4 pieces) are shipped with the unit and are to be field installed on the top of the air-handler using the following procedure and referring to Figure 10.

1. Loosen the screws attaching the heat barrier to the cabinet.
2. Form a 90° bend with the short leg length at approximately 9.9" from the end where the slot is cut in the flange to facilitate bending. The duct flanges are shipped sized for the 24.5" wide cabinet. For the 17.5" and 21" wide cabinets, cut the long leg as shown in Figure 10 to match the cabinet width.
3. Slide the duct flanges onto the screws loosened in step one above. Tighten the screws to secure the flanges.

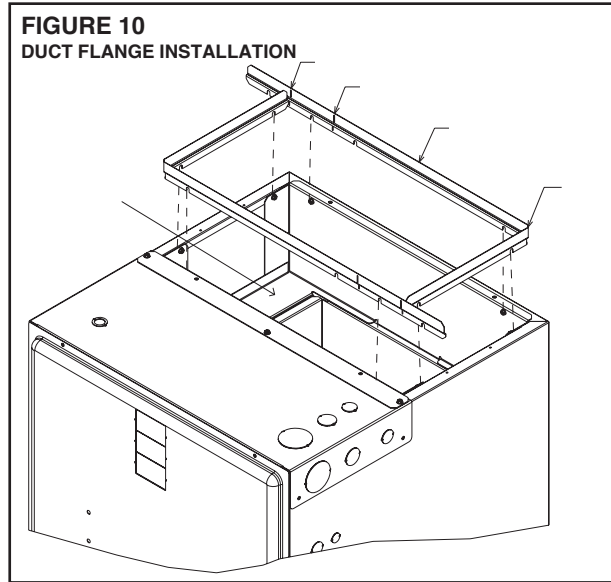

3.6 DUCTWORK

Field ductwork must comply with the National Fire Protection Association NFPA 90A, NFPA 90B and any applicable local ordinance.

▲ WARNING

Do not, under any circumstances, connect return ductwork to any other heat producing device such as fireplace insert, stove, etc. Unauthorized use of such devices may result in fire, carbon monoxide poisoning, explosion, personal injury or property damage.

Sheet metal ductwork run in unconditioned spaces must be insulated and covered with a vapor barrier. Fibrous ductwork may be used if constructed and installed in accordance with SMACNA Construction Standard on Fibrous Glass Ducts. Ductwork must comply with National Fire Protection Association as tested by U/L Standard 181 for Class I Air Ducts. Check local codes for requirements on ductwork and insulation.

- Duct system must be designed within the range of external static pressure the unit is designed to operate against. It is important that the system airflow be adequate. Make sure supply and return ductwork, grills, filters, accessories, etc. are accounted for in total resistance. Refer to the airflow performance tables in this manual to determine the available external static pressure for the particular air-handler model being installed.
- Design the duct system in accordance with "ACCA" Manual "D" Design for Residential Winter and Summer Air Conditioning and Equipment Selection. Latest editions are available from: "ACCA" Air Conditioning Contractors of America, 1513 16th Street, N.W., Washington, D.C. 20036. If duct system incorporates **flexible air duct**, be sure **pressure drop** information (straight length plus all turns) shown in "ACCA" Manual "D" is accounted for in system.
- Supply plenum is attached to the duct flanges supplied with the unit. See Section 3.5.
- **IMPORTANT:** If an elbow is included in the plenum close to the unit, it must not be smaller than the dimensions of the supply duct flange on the unit.
- **IMPORTANT:** The front flange on the return duct if connected to the blower casing must not be screwed into the area where the power wiring is located. Drills or sharp screw points can damage insulation on wires located inside unit.
- Secure the supply and return ductwork to the unit flanges, using proper fasteners for the type of duct used and tape or caulk the duct-to-unit joint as required to prevent air leaks.

WARNING

Do not operate the system without filters. A portion of the dust entrained in the air may temporarily lodge in the duct runs and at the supply registers. Any circulated dust particles could be heated and charred by contact with the heating elements. This residue could soil ceilings, walls, drapes, carpets and other articles in the house. Operating the system without a filter will also allow lint and dirt particles to accumulate on the indoor coil fin and restrict air-flow through the coil. Soot damage may occur even with filters in place when certain types of candles, oil lamps or standing pilots are burned.

3.7 RETURN AIR FILTER

An internal filter rack is not provided with this air-handler. Therefore, an external means of filtering the return air is required. External filters should be sized for a maximum of 300 feet/min air velocity or the maximum velocity recommended by the type of filter installed. One or more return air filter grilles, a filter rack attached to unit return air intake, or a filter rack installed between a sealed return air platform and the return duct are all acceptable means of filtration. All return ducts must be filtered, either at each return grille or at a common filter near the unit.

Important: Do not install a return air filter grille **and** a filter rack at the unit and do not install a filter in the supply duct system.

Filter type, sizing, and placement are critical to heating and cooling system performance. Reduced air-flow can shorten the life of system components such as the compressor, indoor coil, heater elements, over temperature limits, and relays. As filters near the end of their useful life, the pressure drop through them increases. Therefore, it is important to factor the "end of life" (dirty) pressure drop of filters into the external static pressure of the duct system when selecting blower speeds and designing ductwork to assure the system is operating at the design CFM and system reliability is not compromised. Always verify that the system's air-flow is within specifications by performing a temperature rise (heating mode) and/or temperature drop (cooling mode) with all filters in place.

Important: High efficiency pleated filters and electronic air cleaners typically have significantly higher pressure drop than standard efficiency fiberglass filters, especially when they get dirty. Do not use high efficiency filters or electronic air cleaners unless adequate filter area is provided to lower the filter pressure drop to an acceptable level.

3.8 REFRIGERANT LINE CONNECTIONS & CHARGING

3.8.1 PREPARATION

The coil is shipped with a low pressure (5-10 psig) charge of dry nitrogen which will be released when the rubber plugs are removed. Leave the rubber plugs in the refrigerant connection stubs on the air-handler until the refrigerant lines are ready to be brazed to the refrigerant connection stubs to prevent contaminants from entering the coil. Clean the ends of the tubing and coil connection stubs (inside and outside) with an alcohol wipe before inserting the line set tubes into the coil connection stubs to assure a quality leak-free braze joint.

Refer to the outdoor unit installation instructions for details on refrigerant line sizing and installation. Be sure to follow long line length guidelines if they apply.

Route the refrigerant tubing in a manner that does not block service access to the front of the air-handler.

3.8.2 LIQUID LINE FILTER DRIER

A new liquid filter drier must be installed every time any part of the system has been open to the atmosphere, even if it's for a short period of time. The filter drier should be installed close to the air-handler for a system started up in the cooling mode and near the outdoor unit for a heat pump system started up in the heating mode. This allows the filter drier to catch any contaminants in the liquid line before they can enter the indoor or outdoor TXV inlet screen.

3.8.3 BRAZING

Air inside the tubing and coil should be displaced with dry nitrogen prior to the brazing process to prevent the formation of harmful copper oxide inside the tubing. It is very important not to pressurize the system with nitrogen while brazing or pin-hole leaks will form in the braze joint. This is accomplished by removing the gauge port valve core on one of the outdoor unit service valves to allow the pressure to be relieved as the heated nitrogen expands. Fill the system with dry nitrogen through the other service valve gauge port and then turn the nitrogen flow off just before brazing is begun.

Protect the TXV, copper to aluminum suction header joint, and outdoor unit service valves from overheating using a wet rag or heat sink compound. Leave the wet rag or heat sink material in place until the joint and surrounding tubing cools down to a safe temperature. Double tip torches can help minimize brazing time and heat conduction to the heat sensitive components if the flame is turned down and held on the joint just long enough to make the braze joint. With both single and double tip torches, turning the flame up too much and keeping the flame on the joint too long will damage the heat sensitive components even when a wet rag or heat sink compound is used.

Use a sheet metal shield to protect the cabinet's paint from the torch flames during the brazing process. The vapor line insulation should be pushed back on the line about 12 inches from the joint and retained to prevent it from igniting or melting during the brazing process.

After the refrigerant brazed connections are made at the air-handler and the tubing has cooled down sufficiently, replace the coil section access panel if it has been removed and seal the air gap around the connection stubs with the foam rubber gasket included in the air-handler parts bag. Peel the self-adhesive backing off of the foam gasket and position it around the stubs with the adhesive side toward the cabinet, then press it firmly against the cabinet. The gasket is split to allow it to go over the stubs after the refrigerant tubes are brazed to the stubs. (See Figure 12)

After the foam gasket has been installed, the vapor line insulation should be pulled back in place so it contacts the air-handler cabinet to prevent condensate from forming on the cold tube and dripping off. A loosely fitting zip-tie placed around the insulation ½" from the end can be used to hold it in place so it doesn't move away from the cabinet. For air-handlers with TXV's, a section of the insulation will need to be cut out to make room for the externally mounted TXV bulb. (See Section 3.9) Once the bulb is mounted, insulate the bulb with the foam insulation included in the air-handler parts bag, making sure none of the vapor line is uninsulated.

3.8.4 LEAK TESTING

After all braze joints are completed, replace the valve core removed when purging with nitrogen and then leak test the system by pressurizing to 150 psig with dry nitrogen and allow the system to sit for at least 15 minutes (longer if possible) to assure the pressure does not drop.

3.8.5 EVACUATION

If no leaks are detected, evacuate the system down to 500 microns or below before charging the system or opening the service valves on the outdoor unit which will release the charge stored in the outdoor unit into the line set and air-handler coil. Failure to reach 500 microns of vacuum is a sign of a leak or excessive moisture inside the system.

3.8.6 REFRIGERANT CHARGING

Once the evacuation process is completed, break the vacuum with the refrigerant from a refrigerant cylinder or with refrigerant stored in the outdoor unit by opening the outdoor unit service valves. Proceed to charge the system according to the outdoor unit installation instructions.

3.9 TXV SENSING BULB ATTACHMENT

IMPORTANT: DO NOT perform any brazing with the TXV bulb attached to the vapor line. After brazing operations have been completed and the tubing has cooled to the touch, clamp the TXV bulb securely on the vapor line at the 10 o'clock to 2 o'clock position (see Figures 11 and 12) with the strap provided in the parts bag. Insulate the TXV sensing bulb and suction line with the provided pressure sensitive insulation (size 4" x 7") and secure with provided wire ties.

IMPORTANT: TXV sensing bulb should be located on a horizontal section of suction line, just outside of coil box. The copper sensing bulb must never be placed on any aluminum tube as this will result in galvanic corrosion and eventual failure of the aluminum tube.

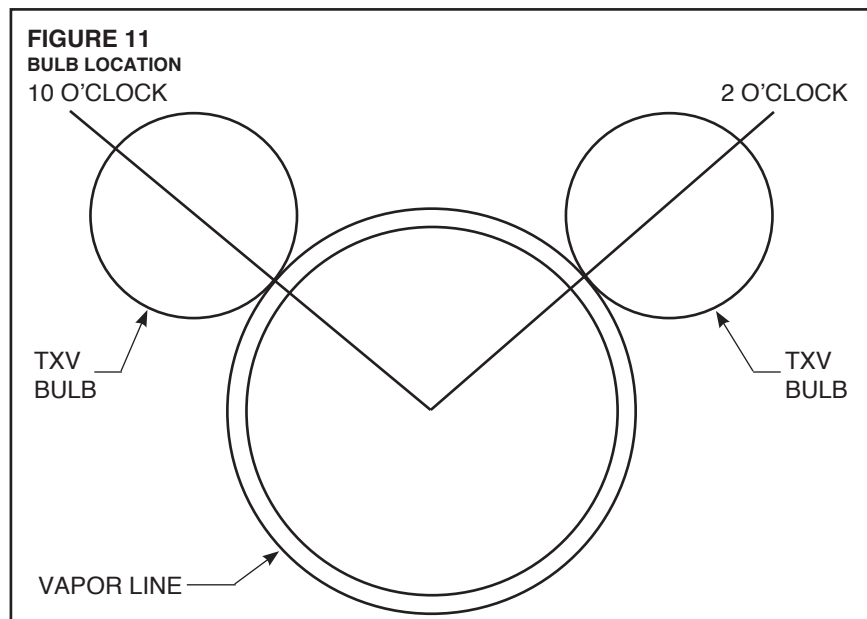
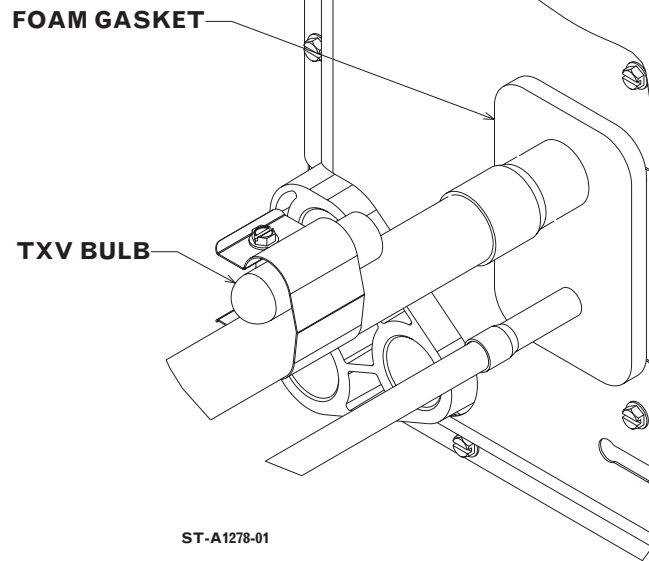

FIGURE 12
TXV BULB & FOAM GASKET LOCATION



3.10 CONDENSATE DRAIN

Consult local codes or ordinances for specific requirements.

IMPORTANT: When making drain fitting connections to the drain pan, use a thin layer of Teflon paste, silicone or Teflon tape and install hand tight.

IMPORTANT: When making drain fitting connections to drain pan, do not overtighten. Overtightening fittings can split pipe connections on the drain pan.

- Install drain lines so they do not block service access to front of the unit. Minimum clearance of 24 inches is required for filter, coil or blower removal and service access.
- Although the condensate drain pan is designed to be self draining, it is recommended that the air-handler cabinet be pitched slightly downward toward the primary drain connection to assure the condensate drains completely from the drain pan. The downward pitch should be approximately 1/8" per foot and in both axes.
- Do not reduce drain line size less than connection size provided on condensate drain pan.
- All drain lines must be pitched downward away from the unit a minimum of 1/8" per foot of line to ensure proper drainage.
- Do not connect condensate drain line to a closed or open sewer pipe. Run condensate to an open drain or outdoors.
- The drain line should be insulated where necessary to prevent sweating and damage due to condensate forming on the outside surface of the line.
- Make provisions for disconnecting and cleaning of the primary drain line should it become necessary. Install a 3 in. trap in the primary drain line as close to the unit as possible. Make sure that the top of the trap is below connection to the drain pan to allow complete drainage of pan (See Figure 13).
- The auxiliary drain line should be run to a place where it will be noticeable if it becomes operational. The building occupant should be warned that a problem exists if water should begin running from the auxiliary drain line. An auxiliary drain shut-off switch can be installed in lieu of an auxiliary drain line. The shut-off switch should be wired into the control circuit so the outdoor unit shuts down should the switch detect water.
- Plug the unused drain connection with the plugs provided in the parts bag, using a thin layer of teflon paste, silicone or teflon tape to form a water tight seal.
- Test the condensate drain pan and drain line after installation is complete. Pour water into drain pan, enough to fill drain trap and line. Check to make sure drain pan is draining completely, no leaks are found in drain line fittings, and water is draining from the open end of the primary drain line.

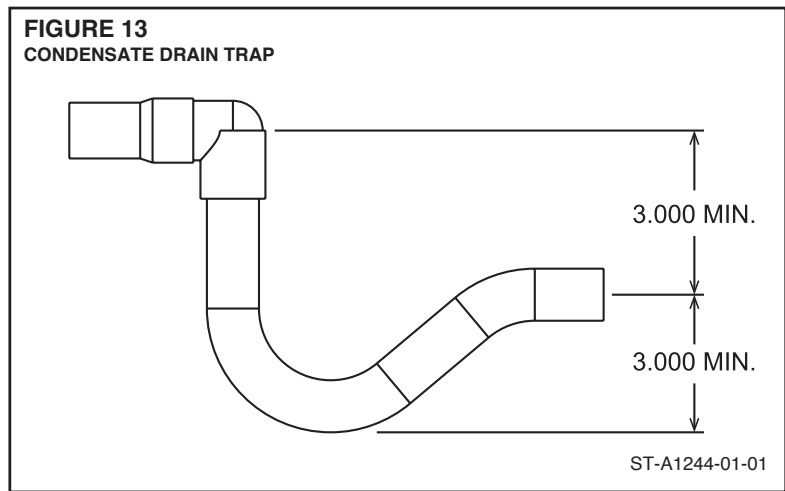

3.11 THERMOSTAT

See instructions for the condensing unit or heat pump for recommended room thermostats.

- On units with one electric heat sequencer (TD₁) (see wiring diagram for electric heater), heat anticipator setting should be .16.
- On units with two electric heat sequencers (TD₁ & TD₂) (see wiring diagram for electric heater), heat anticipator setting should be .32 if both are connected to same stage on thermostat. Setting should be .16 if (TD₁ & TD₂) are connected to separate stages.

NOTE: Some thermostats contain a fixed, non-adjustable heat anticipator. Adjustment is not permitted.

- The thermostat should be mounted 4 to 5 feet above the floor on an inside wall of the living room or a hallway that has good air circulation from the other rooms being controlled by the thermostat. It is essential that there be free air circulation at the location of the same average temperature as other rooms being controlled. Movement of air should not be obstructed by furniture, doors, draperies, etc. The thermostat should not be mounted where it will be affected by drafts, hot or cold water pipes or air ducts in walls, radiant heat from fireplace, lamps, the sun, T.V. or an outside wall. See instruction sheet packaged with thermostat for mounting and installation instructions.

3.12 ELECTRICAL WIRING

Field wiring must comply with the National Electric Code (C.E.C. in Canada) and any applicable local ordinance.

3.12.1 CONFIGURING UNIT FOR 208 VOLT POWER

The control transformer must be configured in the field to operate on a 208 volt electrical supply to assure adequate control voltage (24+ volts) with the reduced supply voltage. The units are shipped from the factory for 220-240 volt applications. For 208 volt applications, disconnect electrical power to the unit and remove the blower access panel and then the control box cover located on the blower housing. Then remove the insulated cap from the 208 volt transformer terminal and move the BLACK wires that are connected to the 240 volt transformer terminal to the 208 volt transformer terminal. Plug the insulated cap onto the transformer 240V terminal.

3.12.2 GROUNDING

- This product must be sufficiently grounded in accordance with National Electrical Code (C.E.C. in Canada) and any applicable local ordinance.

⚠ WARNING

The unit must be permanently grounded. Failure to do so can result in electrical shock causing personal injury or death.

- Grounding may be accomplished by grounding metal conduit when installed in accordance with electrical codes to the unit cabinet.
- Grounding may also be accomplished by attaching ground wire(s) to ground lug(s) provided in the unit wiring compartment.
- Ground lug(s) are located close to wire entrance on left side of unit (upflow). Lug(s) may be moved to marked locations near wire entrance on right side of unit (upflow), if alternate location is more convenient.
- Use of multiple supply circuits require grounding of each circuit to lug(s) provided in unit.

3.12.3 POWER WIRING

It is important that proper electrical power is available for connection to the unit model being installed. See the unit nameplate, wiring diagram and electrical data in the installation instructions.

- If required, install a branch circuit disconnect of adequate size, located within sight of, and readily accessible to the unit.
- **IMPORTANT:** Units with electric heater kits installed may be equipped with one, two, or three 30/60 amp circuit breakers. These breaker(s) protect the internal wiring in the event of a short circuit and serve as a disconnect. Circuit breakers installed within the unit do not provide over-current protection of the supply wiring and therefore may be sized larger than the branch circuit protection.
- Supply circuit power wiring must be 75°C minimum copper conductors only. See Electrical Data in Sections 3.12.5 and 3.12.6 for ampacity, wire size and circuit protector requirement. Supply circuit protective devices may be either fuses or "HACR" type circuit breakers.
- Field power wiring may be connected to either the right, left side or top. Three $7/8"$, $1^{3/32}"$, $1^{31/32}"$ dia. concentric knockouts are provided for connection of power wiring to unit.
- Field power wiring is to be connected to the power terminal block in unit control compartment.
- For units equipped with an electric heater kit, field power wiring is to be connected to the heater kit breaker, terminal block, or pullout disconnect terminals and the power wiring pigtail from the heater kit is to be connected to the unit power terminal block in the unit control compartment. Refer to installation instructions provided with the heater kit for additional details.

3.12.4 COPPER WIRE SIZE - AWG. (3% VOLTAGE DROP)

SUPPLY	LENGTH	200 [61]	12	10	8	8	8	6	6	6	4	4	3	3	2	2	1	0	00
		150 [46]	12	10	10	10	8	8	6	6	6	4	4	3	3	2	1	0	00
		100 [30]	14	12	10	10	8	8	6	6	6	4	4	3	3	2	1	0	00
		50 [15]	14	12	10	10	8	8	6	6	6	4	4	3	3	2	1	0	00
			15	20	25	30	35	40	45	50	60	70	80	90	100	110	125	150	175
WIRE	FEET	SUPPLY CIRCUIT AMPACITY																	
		NOTE: WIRE BASED ON COPPER CONDUCTORS 75°C MINIMUM RATING. FOR MORE THAN 3 CONDUCTORS IN A RACEWAY OR CABLE, SEE N.E.C. FOR DERATING THE AMPACITY OF EACH CONDUCTOR.																	

3.12.5.1 ELECTRICAL DATA – BLOWER MOTOR ONLY – WITHOUT ELECTRIC HEAT: (-)H1V

MODEL (-)H1V	VOLTAGE	PHASE	HERTZ	HP	RPM	CIRCUIT AMPS	MINIMUM CIRCUIT AMPACITY	MAXIMUM OVERCURRENT PROTECTION
2417S	208/240	1	60	1/3	300-1100	2.2	3.0	15
3617S/3621M/3621H	208/240	1	60	1/2	300-1100	3.4	5.0	15
4821S	208/240	1	60	3/4	300-1100	4.0	5.0	15
4821M/6021S	208/240	1	60	3/4	300-1100	4.9	7.0	15
4824S/6024S	208/240	1	60	3/4	300-1100	4.4	6.0	15

3.12.5.2 ELECTRICAL DATA – BLOWER MOTOR ONLY – WITHOUT ELECTRIC HEAT: (-)H2V

MODEL (-)H2V	VOLTAGE	PHASE*	HERTZ	HP	RPM	CIRCUIT AMPS.	MINIMUM CIRCUIT AMPACITY	MAXIMUM CIRCUIT PROTECTOR
2421M	208/230	1	60	1/3	300-1100	1.7	3.0	15
3621M	208/230	1	60	1/2	300-1100	3.4	5.0	15
4821M/6024S	208/230	1	60	3/4	300-1100	4.9	7.0	15
2417S	208/240	1	60	1/3	300-1100	2.2	3.0	15

3.12.6.1 ELECTRICAL DATA WITH ELECTRIC HEAT: (-)H1V

Installation of the UL Listed original equipment manufacturer provided heater kits listed in the following table is recommended for all auxiliary heating requirements.

AIR-HANDLER MODEL (-)H1V	HEATER MODEL NO.	HEATER KW 208/240V	PH/HZ	NO. ELEMENTS - KW PER	TYPE SUPPLY CIRCUIT SINGLE CIRCUIT MULTIPLE CIRCUIT	CIRCUIT AMPS	MOTOR AMPACITY	MINIMUM CIRCUIT AMPACITY	MAXIMUM OVERCURRENT PROTECTION	
2417S (-)H2V2417S	RXBH-17?03J	2.25/3.0	1/60	1-3.0	SINGLE	10.8/12.5	2.2	17/19	20/20	
	RXBH-1724?03J	2.25/3.0	1/60	1-3.0	SINGLE	10.8/12.5	2.2	17/19	20/20	
	RXBH-1724?05J	3.6/4.8	1/60	1-4.8	SINGLE	17.3/20.0	2.2	25/28	25/30	
	RXBH-1724?07J	5.4/7.2	1/60	2-3.6	SINGLE	26.0/30.0	2.2	36/41	40/45	
	RXBH-1724?10J	7.2/9.6	1/60	2-4.8	SINGLE	34.6/40.0	2.2	46/53	50/60	
	RXBH-1724A13J	9.4/12.5	1/60	3-4.17	SINGLE	45.1/52.1	2.2	60/68	60/70	
		3.1/4.2	1/60	1-4.17	MULTIPLE CKT 1	15.0/17.4	2.2	22/25	25/25	
		6.3/8.3	1/60	2-4.17	MULTIPLE CKT 2	30.1/34.7	0	38/44	40/45	
	RXBH-1724A07C	5.4/7.2	3/60	3-2.4	SINGLE	15.0/17.3	2.2	22/25	25/25	
RXBH-1724A10C	7.2/9.6	3/60	3-3.2	SINGLE	20.0/23.1	2.2	28/32	30/35		
RXBH-1724A13C	9.4/12.5	3/60	3-4.17	SINGLE	26.1/30.1	2.2	36/41	40/45		
3617S	RXBH-17?03J	2.25/3.0	1/60	1-3.0	SINGLE	10.8/12.5	3.4	18/20	20/20	
3617S 3621M 3621H	RXBH-1724?03J	2.25/3.0	1/60	1-3.0	SINGLE	10.8/12.5	3.4	18/20	20/20	
	RXBH-1724?05J	3.6/4.8	1/60	1-4.8	SINGLE	17.3/20.0	3.4	26/29	30/30	
	RXBH-1724?07J	5.4/7.2	1/60	2-3.6	SINGLE	26.0/30.0	3.4	37/42	40/45	
	RXBH-1724?10J	7.2/9.6	1/60	2-4.8	SINGLE	34.6/40.0	3.4	48/55	50/60	
	RXBH-1724A13J	9.4/12.5	1/60	3-4.17	SINGLE	45.1/52.1	3.4	61/70	70/70	
		3.1/4.2	1/60	1-4.17	MULTIPLE CKT 1	15.0/17.4	3.4	23/26	25/30	
		6.3/8.3	1/60	2-4.17	MULTIPLE CKT 2	30.1/34.7	0	38/44	40/45	
	RXBH-1724A15J	10.8/14.4	1/60	3-4.8	SINGLE	51.9/60.0	3.4	70/80	70/80	
		3.6/4.8	1/60	1-4.8	MULTIPLE CKT 1	17.3/20.0	3.4	26/30	30/30	
	RXBH-1724A18J	7.2/9.6	1/60	2-4.8	MULTIPLE CKT 2	34.6/40.0	0	44/50	45/50	
		12.8/17.0	1/60	3-5.68	SINGLE	61.6/70.8	3.4	82/93	90/100	
	RXBH-1724A18J	4.3/5.7	1/60	1-5.68	MULTIPLE CKT 1	20.5/23.6	3.4	30/34	30/35	
		8.5/11.3	1/60	2-5.68	MULTIPLE CKT 2	41.1/47.2	0	52/59	60/60	
		5.4/7.2	3/60	3-2.4	SINGLE	15.0/17.3	3.4	23/26	25/30	
	RXBH-1724A10C	7.2/9.6	3/60	3-3.2	SINGLE	20.0/23.1	3.4	30/34	30/35	
	RXBH-1724A13C	9.4/12.5	3/60	3-4.17	SINGLE	26.1/30.1	3.4	37/42	40/45	
	RXBH-1724A15C	10.8/14.4	3/60	3-4.8	SINGLE	30.0/34.6	3.4	42/48	45/50	
	RXBH-1724A18C	12.8/17.0	3/60	3-5.68	SINGLE	35.5/41.0	3.4	49/56	50/60	
	4821S	RXBH-1724?05J	3.6/4.8	1/60	1-4.8	SINGLE	17.3/20.0	4.0	27/30	30/30
		RXBH-1724?07J	5.4/7.2	1/60	2-3.6	SINGLE	26.0/30.0	4.0	38/43	40/45
RXBH-1724?10J		7.2/9.6	1/60	2-4.8	SINGLE	34.6/40.0	4.0	49/55	50/60	
RXBH-1724A15J		10.8/14.4	1/60	3-4.8	SINGLE	51.9/60.0	4.0	70/80	70/80	
		3.6/4.8	1/60	1-4.8	MULTIPLE CKT 1	17.3/20.0	4.0	27/30	30/30	
		7.2/9.6	1/60	2-4.8	MULTIPLE CKT 2	34.6/40.0	0.0	44/50	45/50	
RXBH-1724A18J		12.8/17.0	1/60	3-5.68	SINGLE	61.6/70.8	4.0	82/94	90/100	
		4.3/5.7	1/60	1-5.68	MULTIPLE CKT 1	20.5/23.6	4.0	31/35	35/35	
		8.5/11.3	1/60	2-5.68	MULTIPLE CKT 2	41.1/47.2	0.0	52/59	60/60	
RXBH-24A20J		14.4/19.2	1/60	4-4.8	SINGLE	69.2/80	4.0	92/105	100/110	
		7.2/9.6	1/60	2-4.8	MULTIPLE CKT 1	34.6/40.0	4.0	49/55	50/60	
		7.2/9.6	1/60	2-4.8	MULTIPLE CKT 2	34.6/40.0	0.0	44/50	45/50	
RXBH-24A25J		18.0/24.0	1/60	6-4.0	SINGLE	86.4/99.9	4.0	113/130	125/150	
		6.0/8.0	1/60	2-4.0	MULTIPLE CKT 1	28.8/33.3	4.0	42/47	45/50	
		6.0/8.0	1/60	2-4.0	MULTIPLE CKT 2	28.8/33.3	0.0	36/42	40/45	
		6.0/8.0	1/60	2-4.0	MULTIPLE CKT 3	28.8/33.3	0.0	36/42	40/45	
RXBH-1724A07C		5.4/7.2	3/60	3-2.4	SINGLE	15.0/17.3	4.0	24/27	25/30	
RXBH-1724A10C		7.2/9.6	3/60	3-3.2	SINGLE	20.0/23.1	4.0	30/34	30/35	
RXBH-1724A15C		10.8/14.4	3/60	3-4.8	SINGLE	30.0/34.6	4.0	43/49	45/50	
RXBH-1724A18C		12.8/17.0	3/60	3-2.84	SINGLE	35.6/41.0	4.0	50/57	50/60	
RXBH-24A20C*		14.4/19.2	3/60	3-3.2	SINGLE	40.0/46.2	4.0	55/63	60/70	
		7.2/9.6	3/60	3-3.2	MULTIPLE CKT 1	20.0/23.1	4.0	30/34	30/35	
		7.2/9.6	3/60	3-3.2	MULTIPLE CKT 2	20.0/23.1	0.0	25/29	25/30	
RXBH-24A25C*		18.0/24.0	3/60	6-4.0	SINGLE	50.0/57.8	4.0	68/78	70/80	
		9.0/12.0	3/60	3-4.0	MULTIPLE CKT 1	25.0/28.9	4.0	37/42	40/45	
		9.0/12.0	3/60	3-4.0	MULTIPLE CKT 2	25.0/28.9	0.0	32/37	35/40	

? Heater Kit Connection Type A=Breaker B=Terminal Block C=Pullout Disconnect

3.12.6.1 ELECTRICAL DATA WITH ELECTRIC HEAT: (-)H1V - continued

AIR-HANDLER MODEL (-)H1V	HEATER MODEL NO.	HEATER KW 208/240V	PH/HZ	NO. ELEMENTS - KW PER	TYPE SUPPLY CIRCUIT SINGLE CIRCUIT MULTIPLE CIRCUIT	CIRCUIT AMPS	MOTOR AMPACITY	MINIMUM CIRCUIT AMPACITY	MAXIMUM OVERCURRENT PROTECTION
4821M 6021S	RXBH-1724?05J	3.6/4.8	1/60		SINGLE	17.3/20.0	4.9	28/32	30/35
	RXBH-1724?07J	5.4/7.2	1/60		SINGLE	26.0/30.0	4.9	39/44	40/45
	RXBH-1724?10J	7.2/9.6	1/60		SINGLE	34.6/40.0	4.9	50/57	50/60
		10.8/14.4	1/60		SINGLE	51.9/60.0	4.9	72/82	80/90
	RXBH-1724A15J	3.6/4.8	1/60		MULTIPLE CKT 1	17.3/20.0	4.9	28/32	30/35
		7.2/9.6	1/60		MULTIPLE CKT 2	34.6/40.0	0	44/50	45/50
		12.8/17	1/60		SINGLE	61.6/70.8	4.9	84/95	90/100
	RXBH-1724A18J	6.4/8.5	1/60		MULTIPLE CKT 1	30.8/35.4	4.9	45/51	45/60
		6.4/8.5	1/60		MULTIPLE CKT 2	30.8/35.4	0	39/45	40/45
		14.4/19.2	1/60		SINGLE	69.2/80.0	4.9	93/107	100/110
	RXBH-24A20J	7.2/9.6	1/60		MULTIPLE CKT 1	34.6/40.0	4.9	50/57	50/60
		7.2/9.6	1/60		MULTIPLE CKT 2	34.6/40.0	0	44/50	45/50
		18.0/24.0	1/60		SINGLE	87.0/99.9	4.9	115/132	125/150
	RXBH-24A25J	6.0/8.0	1/60		MULTIPLE CKT 1	29.0/33.3	4.9	43/48	45/50
		6.0/8.0	1/60		MULTIPLE CKT 2	29.0/33.3	0	37/42	40/45
	6.0/8.0	1/60		MULTIPLE CKT 3	29.0/33.3	0	37/42	40/45	
4824S 6024S	RXBH-1724?05J	3.6/4.8	1/60	1-4.8	SINGLE	17.3/20.0	4.4	28/31	30/35
	RXBH-1724?07J	5.4/7.2	1/60	2-3.6	SINGLE	26.0/30.0	4.4	38/43	40/45
	RXBH-1724?10J	7.2/9.6	1/60	2-4.8	SINGLE	34.6/40.0	4.4	49/56	50/60
	RXBH-1724A15J	10.8/14.4	1/60	3-4.8	SINGLE	51.9/60.0	4.4	71/81	80/90
	RXBH-1724A15J	3.6/4.8	1/60	1-4.8	MULTIPLE CKT1	17.3/20.0	4.4	28/31	30/35
		7.2/9.6	1/60	2-4.8	MULTIPLE CKT 2	34.6/40.0	0	44/50	45/50
	RXBH-1724A18J	12.8/17	1/60	4-4.26	SINGLE	61.6/70.8	4.4	83/94	90/100
	RXBH-1724A18J	6.4/8.5	1/60	2-4.26	MULTIPLE CKT 1	30.8/35.4	4.4	44/50	45/50
		6.4/8.5	1/60	2-4.26	MULTIPLE CKT 2	30.8/35.4	0	39/45	40/45
	RXBH-24A20J	14.4/19.2	1/60	4-4.8	SINGLE	69.2/80.0	4.4	93/106	100/110
	RXBH-24A20J	7.2/9.6	1/60	2-4.8	MULTIPLE CKT 1	34.6/40.0	4.4	49/56	50/60
		7.2/9.6	1/60	2-4.8	MULTIPLE CKT 2	34.6/40.0	0	44/50	45/50
	RXBH-24A25J	18.0/24.0	1/60	6-4.0	SINGLE	86.4/99.9	4.4	114/131	125/150
	RXBH-24A25J	6.0/8.0	1/60	2-4.0	MULTIPLE CKT 1	28.8/33.3	4.4	42/48	45/50
		6.0/8.0	1/60	2-4.0	MULTIPLE CKT 2	28.8/33.3	0	36/42	40/45
		6.0/8.0	1/60	2-4.0	MULTIPLE CKT 3	28.8/33.3	0	36/42	40/45
	RXBH-24A30J (6024S only) (1800 CFM only)	21.6/28.8	1/60	6-4.8	SINGLE	103.8/120.0	4.4	136/156	150/175
	RXBH-24A30J (6024S only) (1800 CFM only)	7.2/9.6	1/60	2-4.8	MULTIPLE CKT 1	34.6/40.0	4.4	49/56	50/60
		7.2/9.6	1/60	2-4.8	MULTIPLE CKT 2	34.6/40.0	0	44/50	45/50
		7.2/9.6	1/60	2-4.8	MULTIPLE CKT 3	34.6/40.0	0	44/50	45/50
	RXBH-1724A07C	5.4/7.2	3/60	3-2.4	SINGLE	15.0/17.3	4.4	25/28	25/30
	RXBH-1724A10C	7.2/9.6	3/60	3-3.2	SINGLE	20.0/23.1	4.4	31/35	35/35
	RXBH-1724A15C	10.8/14.4	3/60	3-4.8	SINGLE	30.0/34.6	4.4	43/49	45/50
	RXBH-1724A18C	12.8/17.0	3/60	3-2.84	SINGLE	35.6/41.0	4.4	50/57	50/60
		14.4/19.2	3/60	3-3.2	SINGLE	40.0/46.2	4.4	56/64	60/70
	RXBH-24A20C*	7.2/9.6	3/60	3-3.2	MULTIPLE CKT 1	20.0/23.1	4.4	31/35	35/35
		7.2/9.6	3/60	3-3.2	MULTIPLE CKT 2	20.0/23.1	0	25/29	25/30
	RXBH-24A25C*	18.0/24.0	3/60	6-4.0	SINGLE	50.0/57.8	4.4	68/78	70/80
	RXBH-24A25C	9.0/12.0	3/60	3-4.0	MULTIPLE CKT 1	25.0/28.9	4.4	37/42	40/45
		9.0/12.0	3/60	3-4.0	MULTIPLE CKT 2	25.0/28.9	0	32/37	35/40
RXBH-24A30C* (1800 CFM only)	21.6/28.8	3/60	6-4.8	SINGLE	60.0/69.4	4.4	81/93	90/100	
RXBH-24A30C (6024S only) (1800 CFM only)	10.8/14.4	3/60	3-4.8	MULTIPLE CKT 1	30.0/34.7	4.4	43/50	45/50	
	10.8/14.4	3/60	3-4.8	MULTIPLE CKT 2	30.0/34.7	0	38/44	40/45	

NOTES:

- * Values only. No single point kit available.
- Supply circuit protective devices may be fuses or “HACR” type circuit breakers.
- Largest motor load is included in single circuit and multiple circuit 1.
- J Voltage (230V) single phase air-handlers are designed to be used with single or three phase 208/240 volt electric heaters. To connect 3-phase power to the air handler terminal block, bring only two leads to the terminal block, cap, insulate and fully secure the third lead.
- If the heater kit is listed with single and multiple circuits, the kit is shipped from factory as multiple circuits. For single phase applications, Jumper Bar Kit RXBJ-A21 or RXBJ-A31 can be used to convert multiple circuits to a single supply circuit. Refer to Section 6.2 for details.

? Heater Kit Connection Type A=Breaker B=Terminal Block C=Pullout Disconnect

3.12.6.2 ELECTRICAL DATA WITH ELECTRIC HEAT: (-)H2V

Installation of the UL Listed original equipment manufacturer provided heater kits listed in the table below is recommended for all auxiliary heating requirements.

Model Size (-)H2V	Manufacturer Model Number	Type Supply Circuit	Voltage	PH/HZ	Heater kW	Heater AMPS	Motor Ampacity	Minimum Circuit Ampacity	Maximum Overcurrent Protection
2421M	RXBH-1724?03J	Single	208/240	1/60	2.25/3.0	10.8/12.5	1.7	16/18	20/20
	RXBH-1724?05J	Single	208/240	1/60	3.6/4.8	17.3/20.0	1.7	24/28	25/30
	RXBH-1724?07J	Single	208/240	1/60	5.4/7.2	26.0/30.0	1.7	35/40	35/40
	RXBH-1724?10J	Single	208/240	1/60	7.2/9.6	34.6/40.0	1.7	46/53	50/60
3621M	RXBH-1724?03J	Single	208/240	1/60	2.25/3.0	10.8/12.5	3.4	18/20	20/20
	RXBH-1724?05J	Single	208/240	1/60	3.6/4.8	17.3/20.0	3.4	26/30	30/30
	RXBH-1724?07J	Single	208/240	1/60	5.4/7.2	26.0/30.0	3.4	37/42	40/45
	RXBH-1724?10J	Single	208/240	1/60	7.2/9.6	34.6/40.0	3.4	48/55	50/60
	RXBH-1724A15J	Single	208/240	1/60	10.8/14.4	51.9/60.0	3.4	70/80	70/80
		MULTI. CKT 1	208/240	1/60	3.6/4.8	17.3/20.0	3.4	26/30	30/30
		MULTI. CKT 2	208/240	1/60	7.2/9.6	34.6/40.0	0	44/50	45/50
	RXBH-1724A18J	Single	208/240	1/60	12.8/17	61.6/70.8	3.4	82/93	90/100
		MULTI. CKT 1	208/240	1/60	4.3/5.7	20.5/23.6	3.4	30/34	30/35
		MULTI. CKT 2	208/240	1/60	8.5/11.3	41.1/47.2	0	52/59	60/60
4821M	RXBH-1724?05J	Single	208/240	1/60	3.6/4.8	17.3/20.0	4.9	28/32	30/35
	RXBH-1724?07J	Single	208/240	1/60	5.4/7.2	26.0/30.0	4.9	39/44	40/45
	RXBH-1724?10J	Single	208/240	1/60	7.2/9.6	34.6/40.0	4.9	50/57	50/60
	RXBH-1724A15J	Single	208/240	1/60	10.8/14.4	51.9/60.0	4.9	72/82	80/90
		MULTI. CKT 1	208/240	1/60	3.6/4.8	17.3/20.0	4.9	28/32	30/35
		MULTI. CKT 2	208/240	1/60	7.2/9.6	34.6/40.0	0	44/50	45/50
	RXBH-1724A18J	Single	208/240	1/60	12.8/17	61.6/70.8	4.9	84/95	90/100
		MULTI. CKT 1	208/240	1/60	6.4/8.5	30.8/35.4	4.9	45/51	45/60
		MULTI. CKT 2	208/240	1/60	6.4/8.5	30.8/35.4	0	39/45	40/45
	RXBH-24A20J	Single	208/240	1/60	14.4/19.2	69.2/80.0	4.9	93/107	100/110
		MULTI. CKT 1	208/240	1/60	7.2/9.6	34.6/40.0	4.9	50/57	50/60
		MULTI. CKT 2	208/240	1/60	7.2/9.6	34.6/40.0	0	44/50	45/50
	RXBH-24A25J	Single	208/240	1/60	18.0/24.0	87.0/99.9	4.9	115/132	125/150
		MULTI. CKT 1	208/240	1/60	6.0/8.0	29.0/33.3	4.9	43/48	45/50
		MULTI. CKT 2	208/240	1/60	6.0/8.0	29.0/33.3	0	37/42	40/45
		MULTI. CKT 3	208/240	1/60	6.0/8.0	29.0/33.3	0	37/42	40/45
6024S	RXBH-1724?07J	Single	208/240	1/60	5.4/7.3	26.0/30.0	4.9	39/44	40/45
	RXBH-1724?10J	Single	208/240	1/60	5.4/7.2	26.0/30.0	4.9	39/44	40/45
	RXBH-1724A15J	Single	208/240	1/60	10.8/14.4	51.9/60.0	4.9	72/82	80/90
		MULTI. CKT 1	208/240	1/60	3.6/4.8	17.3/20.0	4.9	28/32	30/35
		MULTI. CKT 2	208/240	1/60	7.2/9.6	34.6/40.0	0	44/50	45/50
	RXBH-1724A18J	Single	208/240	1/60	12.8/17	61.6/70.8	4.9	84/95	90/100
		MULTI. CKT 1	208/240	1/60	6.4/8.5	30.8/35.4	4.9	45/51	45/60
		MULTI. CKT 2	208/240	1/60	6.4/8.5	30.8/35.4	0	39/45	40/45
	RXBH-24A20J	Single	208/240	1/60	14.4/19.2	69.2/80.0	4.9	93/107	100/110
		MULTI. CKT 1	208/240	1/60	7.2/9.6	34.6/40.0	4.9	50/57	50/60
		MULTI. CKT 2	208/240	1/60	7.2/9.6	34.6/40.0	0	44/50	45/50
	RXBH-24A25J	Single	208/240	1/60	18.0/24.0	87.0/99.9	4.9	115/132	125/150
		MULTI. CKT 1	208/240	1/60	6.0/8.0	29.0/33.3	4.9	43/48	45/50
		MULTI. CKT 2	208/240	1/60	6.0/8.0	29.0/33.3	0	37/42	40/45
		MULTI. CKT 3	208/240	1/60	6.0/8.0	29.0/33.3	0	37/42	40/45
	RXBH-24A30J	Single	208/240	1/60	21.6/28.8	103.8/120.0	4.9	150/175	136/156
RXBH-24A30J	MULTI. CKT 1	208/240	1/60	7.2/9.6	34.6/40.0	4.9	50/60	49/56	
	MULTI. CKT 2	208/240	1/60	2-4.8	34.6/40.0	0	45/50	44/50	
	MULTI. CKT 3	208/240	1/60	7.2/9.6	34.6/40.0	0	45/50	44/50	

NOTES:

- Supply circuit protective devices may be fuses or “HACR” type circuit breakers.
- Largest motor load is included in single circuit and multiple circuit 1.
- J Voltage (230V) single phase air-handlers are designed to be used with single or three phase 208/240 volt electric heaters. To connect 3-phase power to the air handler terminal block, bring only two leads to the terminal block, cap, insulate and fully secure the third lead.
- If the heater kit is listed with single and multiple circuits, the kit is shipped from factory as multiple circuits. For single phase applications, Jumper Bar Kit RXBJ-A21 or RXBJ-A31 can be used to convert multiple circuits to a single supply circuit. Refer to Section 6.2 for details.

? Heater Kit Connection Type A=Breaker B=Terminal Block C=Pullout Disconnect

3.12.7 ELECTRIC HEATER KIT SUPPLEMENTAL INFORMATION

MFD. MO./YEAR 01/2006 AIR CONDITIONING DIVISION MADE IN THE U.S.A. FAIT DANS L'USA

FRQ. MO./JANNE

MODEL/MODELE # SERIAL/EN SERIE # M0106 38751

VOLTS 208/240 PH/HZ 1/60 MOTOR HP./F.L.A. 1/2 4.1 MOTEUR PSC/F.L.A.

ATTENTION: MARK HEATER INSTALLED/L'APPAREIL DE CHAUFFAGE DE MARQUE A INSTALLER

HEATER MODEL/MODELE D'APPAREIL DE CHAUFFAGE	TYPE SUPPLY CIRCUIT/TYPES LE CIRCUIT DE PROVISION	VOLTAGE/TENSION	PHASE	KW	HEATER AMPS/AMPLIS D'APPAREIL DE CHAUFFAGE	MOTOR AMPS/LES AMPLIS MOTEURS	MAXIMUM OVERCURRENT PROTECTION/LA PROTECTION MAXIMUM DE OVERCURRENT	MINIMUM BRANCH CIRCUIT AMPACITY/AMPACITY MINIMUM DE CIRCUIT DE BRANCHE
NO HEAT				0.0		4.1	15	5.2
RXBH-24A05J	SINGLE	208/240	1/60	3.6/4.8	17.3/20.0	6.0	30/35	30/33
RXBH-24A07J	SINGLE	208/240	1/60	5.4/7.2	26.0/30.0	6.0	40/45	40/45
RXBH-24A10J	SINGLE	208/240	1/60	7.2/9.6	34.6/40.0	6.0	60/60	51/58
RXBH-24A15J	SINGLE	208/240	1/60	10.8/14.4	51.9/60.0	6.0	80/90	73/83
RXBH-24A15J	MULTI CKT 1	208/240	1/60	3.6/4.8	17.3/20.0	6.0	30/35	30/33
RXBH-24A15J	MULTI CKT 2	208/240	1/60	7.2/9.6	34.6/40.0	0.0	45/50	44/50
RXBH-24A18J	SINGLE	208/240	1/60	12.8/17.0	61.2/70.8	6.0	90/100	84/96
RXBH-24A18J	MULTI CKT 1	208/240	1/60	6.4/8.5	30.8/35.4	6.0	50/60	46/52
RXBH-24A18J	MULTI CKT 2	208/240	1/60	6.4/8.5	30.8/35.4	0.0	40/45	39/45
RXBH-24A20J	SINGLE	208/240	1/60	14.4/19.2	69.2/80.0	6.0	100/110	94/108
RXBH-24A20J	MULTI CKT 1	208/240	1/60	7.2/9.6	34.6/40.0	6.0	60/60	51/58
RXBH-24A20J	MULTI CKT 2	208/240	1/60	7.2/9.6	34.6/40.0	0.0	45/50	44/50
RXBH-24A07C	SINGLE	208/240	3/60	5.4/7.2	15.0/17.3	6.0	30/30	27/30
RXBH-24A10C	SINGLE	208/240	3/60	7.2/9.6	20.0/23.1	6.0	35/40	33/37
RXBH-24A15C	SINGLE	208/240	3/60	10.8/14.4	30.0/34.6	6.0	45/60	45/51
RXBH-24A18C	SINGLE	208/240	3/60	12.4/17.0	35.6/41.0	6.0	60/60	52/59
RXBH-24A18C	MULTI CKT 1	208/240	3/60	6.4/8.5	17.8/20.5	6.0	30/35	30/34
RXBH-24A18C	MULTI CKT 2	208/240	3/60	6.4/8.5	17.8/20.5	0.0	25/30	23/26
RXBH-24A20C	SINGLE	208/240	3/60	14.2/19.2	40.0/46.2	6.0	60/70	58/66
RXBH-24A20C	MULTI CKT 1	208/240	3/60	7.2/9.6	20.0/23.1	6.0	35/40	33/37
RXBH-24A20C	MULTI CKT 2	208/240	3/60	7.2/9.6	20.0/23.1	0.0	25/30	25/29

S = SINGLE CIRCUIT/CIRCUIT SIMPLE M = MULTIPLE CIRCUIT/CIRCUIT MULTIPLE

INDOOR BLOWER MOTOR LOAD INCLUDED IN CIRCUIT # 1 OR TOTAL SUPPLY WIRE MUST BE RATED AT 75°C MINIMUM COPPER CONDUCTORS ONLY. TEST EXTERNAL STATIC RANGE .1 TO .5 IN. W.C. (HEAT PUMP & ELECTRIC HEAT).

UNITS WITH ELECTRIC HEATERS: CLEARANCE TO COMBUSTIBLE MATERIAL TO BE 0 IN. TO UNIT CASING AND 0 IN. TO PLENUM AND DUCT FOR FIRST 36 IN. MODELS HAVE INTEGRAL CIRCUIT BREAKERS WHICH PROVIDE SUPPLEMENTARY OVERCURRENT PROTECTION AND SERVE AS A MAINTENANCE "DISCONNECT". SUPPLY CIRCUIT NOT TO EXCEED 120 VOLTS TO GROUND ON SINGLE PHASE UNITS. REPLACE LINE SIDE BREAKER COVER(S) AFTER MAKING WIRING CONNECTIONS TO BREAKER(S). IF BLOWER-CONTROL ASSEMBLY REQUIRES REMOVAL, SEE "WARNING HAZARDOUS VOLTAGE".

CHARGEMENT DU MOTEUR SOUFFLEUR INTERNE INCLUS DANS LE CIRCUIT # 1 OU CAPACITÉ DU CÂBLAGE D'ALIMENTATION TOTAL DOIT ÊTRE DE 75°C DU MINIMUM DE CONDUCTEURS DE CUIVRE SEULEMENT. TESTER L'INTERVALLE STATIQUE EXTERNE : 1 À 5 PO W.C. (THERMOPOMPE ET CHAUFFAGE ÉLECTRIQUE)

UNITÉS AVEC CHAUFFAGES ÉLECTRIQUES : LE DÉGAGEMENT AUX MATIÈRES COMBUSTIBLES DOIT ÊTRE DE 0 po AU BOITIER DE L'UNITÉ ET DE 0 po AU PLENUM ET CONDUIT POUR LES 36 PREMIERS po. LES MODÈLES DISPOSENT DE DISJONCTEURS INTÉGRÉS QUI FOURNISSENT UNE PROTECTION SUPPLÉMENTAIRE DE SURINTENSITÉ DE COURANT ET SERVENT DE « SECTIONNEUR » D'ENTRETIEN. LE CIRCUIT D'ALIMENTATION NE DOIT PAS DÉPASSER 120 VOLTS JUSQU'AU SOL SUR DES UNITÉS MONOPHASÉES. REMPLACER LE(S) COUVERCLE(S) DU DISJONCTEUR DU CÔTÉ SECTEUR APRÈS AVOIR EFFECTUÉ LA CONNEXION DES CÂBLAGES AU(X) DISJONCTEUR(S). SI L'ASSEMBLAGE DE CONTRÔLE DU VENTILATEUR A BESOIN D'ÊTRE DÉASSEMBLÉ, CONSULTER "AVERTISSEMENT DE TENSION DANGEREUSE"

If a heater kit is listed both Single and Multi-circuit, the kit is shipped as a Multi-circuit and will require a single point kit.

Contractor should "mark or check" the left column for the kit installed.

These are the required maximum and minimum circuit breaker sizes for overcurrent protection and should not be confused with the size of the breakers installed in the heater kit.

Only listed kits can be applied

Heater Kit Supplemental Information: What allows the manufacturer to use standard Circuit Breakers up to 60 amps inside the air handler, when using an approved Heater Kit?

National Electric Code (Section 424-22b) and UL standards allow subdividing heating element circuits, of less than 48 amps, using breakers of not more than 60 amps. Additionally per NEC 424-3b, a rating not less than 125 percent of the load and NEC 424-22c, which describes the supplementary overcurrent protection required to be factory-installed within, or on the heater. The breakers in the heater kit are not, and have never been intended to protect power wiring leading to the air handler unit. The breakers in the heating kit are for short circuit protection and to provide a disconnect. All internal unit wiring, where the breakers apply, has been UL approved for short circuit protection.

Ampacity, (not breaker size), determines supply circuit wire size. The ampacity listed on the unit rating plate and the Maximum and Minimum circuit breaker size (noted above) or in the units specification sheet or installation instructions provides the information to properly select wire and circuit breaker/protector size. The National Electric Code (NEC) specifies that the supply or branch circuit must be protected at the source.

3.12.8 CONTROL WIRING

IMPORTANT: Class 2 low voltage control wire should not be run in conduit with power wiring and must be separated from power wiring, unless class 1 wire of proper voltage rating is used.

- Low voltage control wiring should be 18 Awg. color-coded. For lengths longer than 100 ft., 16 Awg. wire should be used.
- Low voltage control connections are made to low voltage pigtailed extending from top of air handler (upflow position - see Figure 3). Connections for control wiring are made with wire nuts. Control wiring knockouts (5/8 and 7/8) are also provided on the right and left side of the unit for side connection.
- See Section 3.12.9 below for control wiring connections.
- Make sure, after installation, separation of control wiring and power wiring has been maintained.
- See Section 3.12.1 for how to reconfigure transformer for 208 volt applications.

3.12.9 THERMOSTAT & CONTROL WIRING CONNECTIONS

NOTE: The low voltage application diagrams shown in Figures 14 - 28 are generic. The outdoor unit and thermostat being installed may not have all the characteristics shown or may not wire exactly as shown. Refer to the diagrams and information supplied with the outdoor unit and thermostat to assure they are wired according to the manufacturer's instructions.

WIRE COLOR CODE:

BK - BLACK	G - GREEN	P - PINK	W - WHITE
BR - BROWN	GY - GRAY	PR - PURPLE	Y - YELLOW
GL - BLUE	O - ORANGE	R - RED	

FIGURE 14
TYPICAL THERMOSTAT: SINGLE-STAGE COOLING W / ELECTRIC HEAT

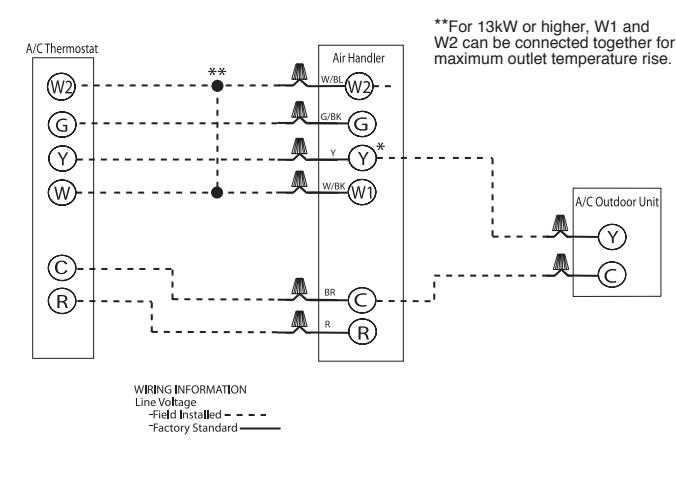

FIGURE 15
TYPICAL THERMOSTAT: 1-STAGE COOLING UNIT WITH ELECTRIC HEAT USING A HUMIDISTAT FOR DEHUMIDIFICATION

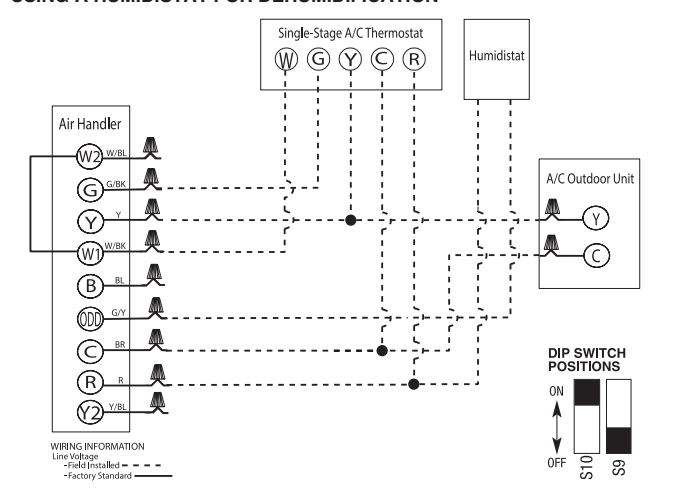

FIGURE 16
TYPICAL THERMOSTAT: SINGLE-STAGE COOLING WITH ELECTRIC HEAT USING 2-STAGE DEHUMIDIFYING THERMOSTAT

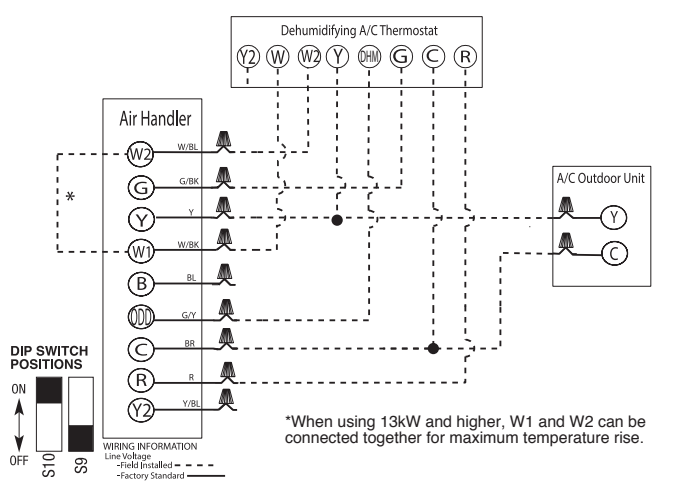
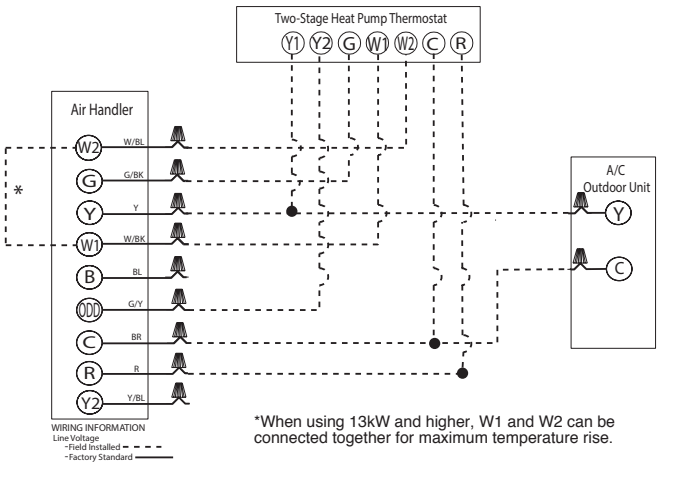
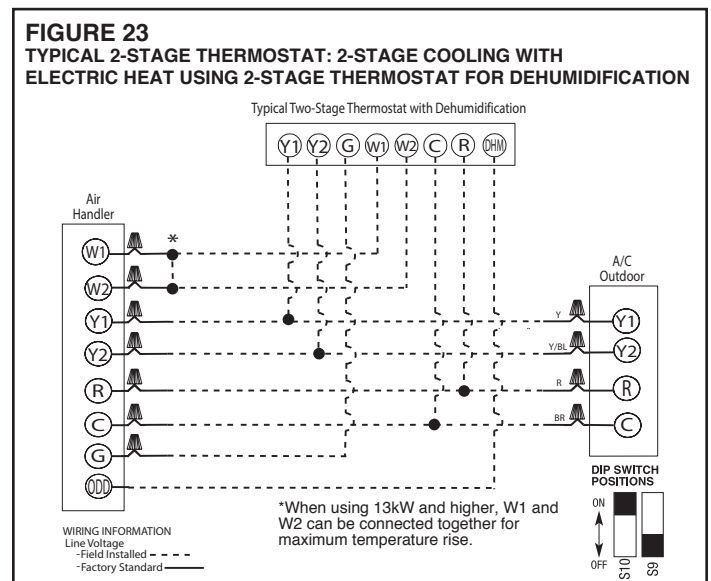
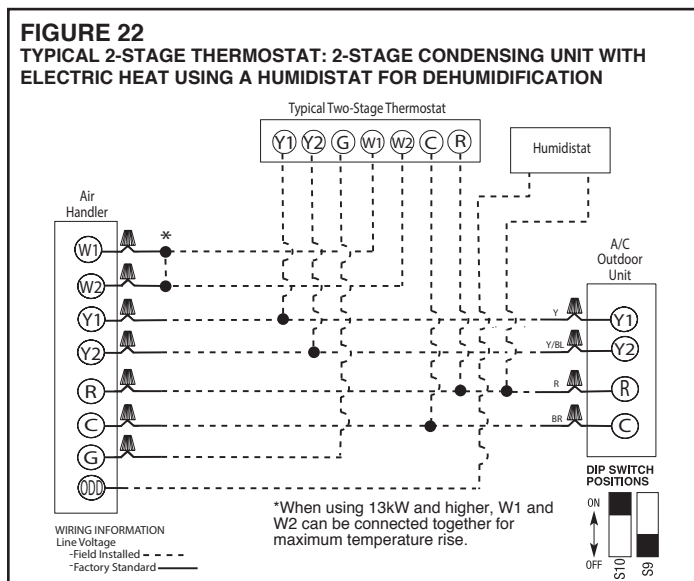
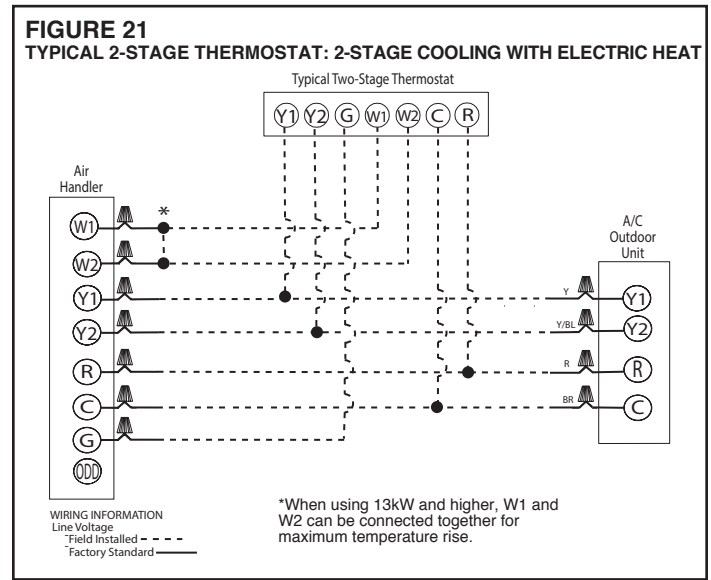
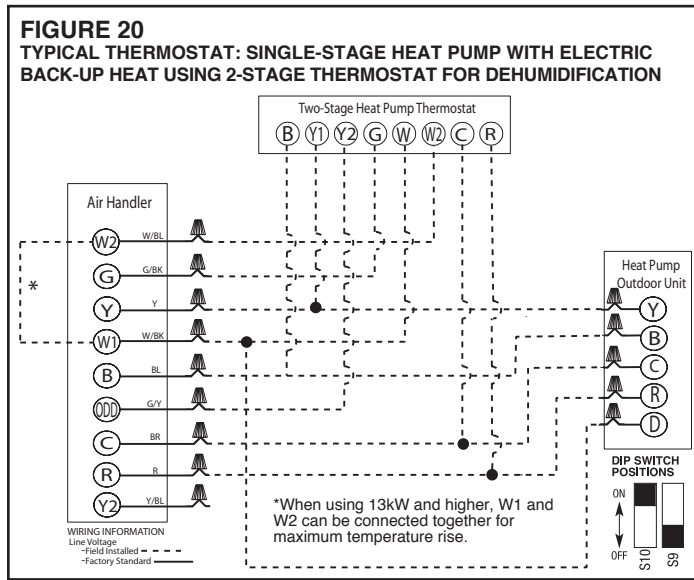
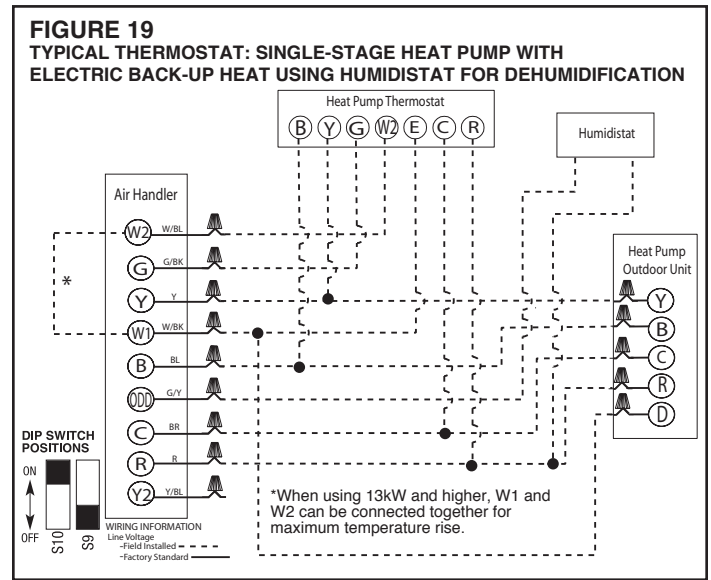
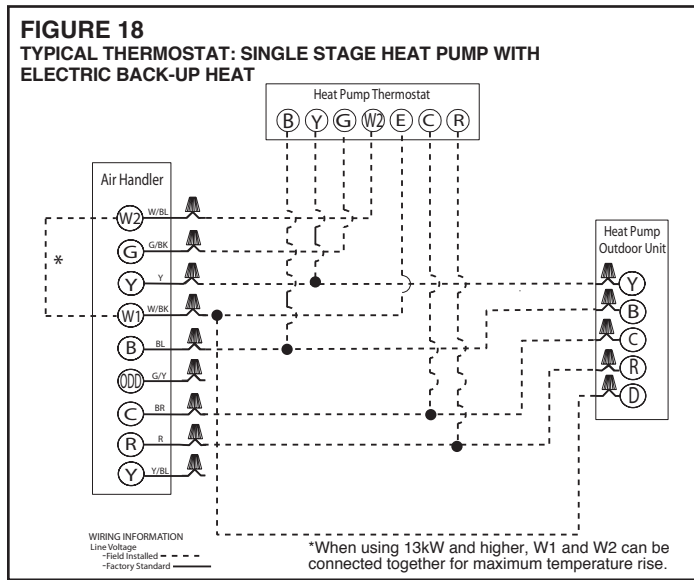

FIGURE 17
TYPICAL THERMOSTAT: SINGLE-STAGE COOLING WITH ELECTRIC HEAT USING 2-STAGE THERMOSTAT FOR DEHUMIDIFICATION



3.12.9 THERMOSTAT & CONTROL WIRING CONNECTIONS - continued



3.12.9 THERMOSTAT & CONTROL WIRING CONNECTIONS - continued

FIGURE 24
2-STAGE CONDENSING UNIT WITH ELECTRIC HEAT USING A 2-STAGE THERMOSTAT WITH DEHUMIDIFICATION AND A MALFUNCTION LIGHT WHEN OUTDOOR UNIT HAS "L" OUTPUT

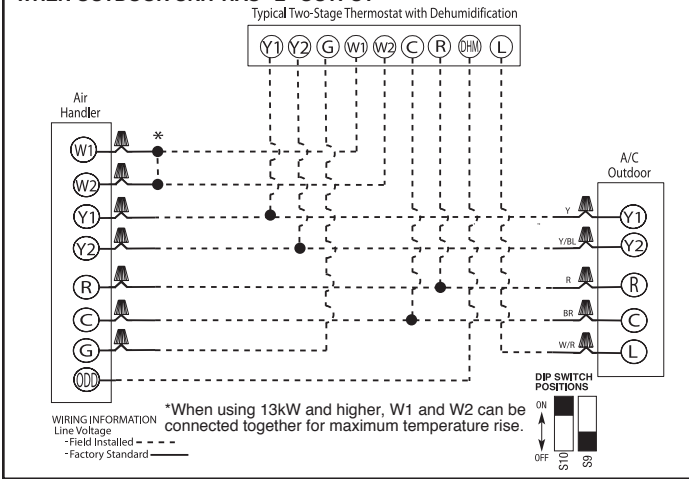

FIGURE 25
TYPICAL 2-STAGE THERMOSTAT: 2-STAGE HEAT PUMP WITH ELECTRIC BACK-UP HEAT

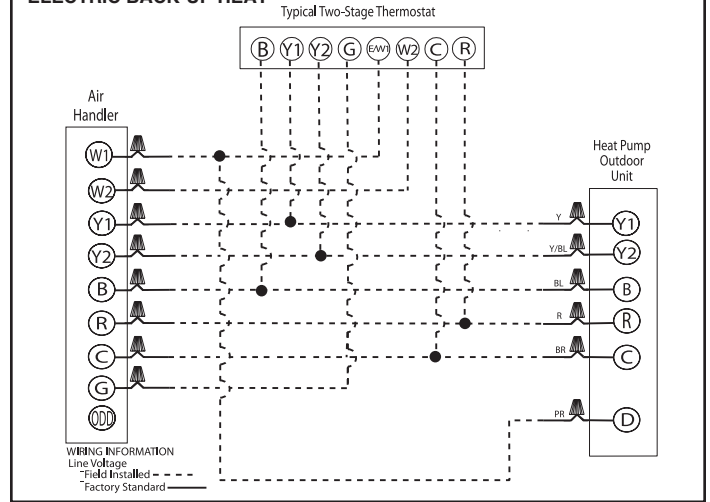

FIGURE 26
TYPICAL 2-STAGE THERMOSTAT: 2-STAGE HEAT PUMP WITH ELECTRIC BACK-UP HEAT USING HUMIDISTAT FOR DEHUMIDIFICATION

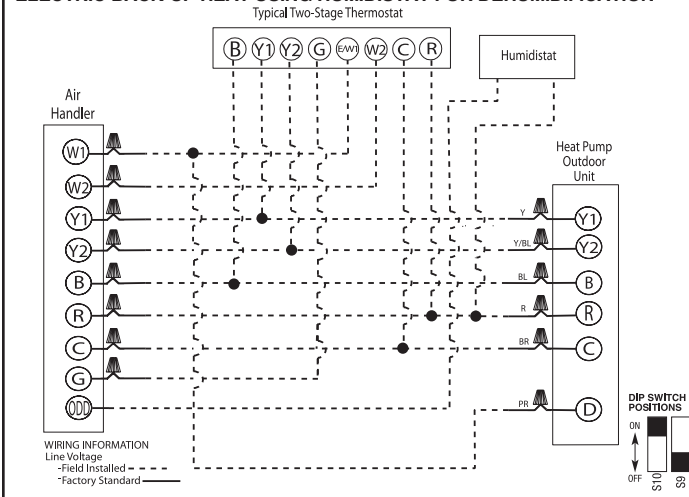

FIGURE 27
TYPICAL 2-STAGE THERMOSTAT: 2-STAGE HEAT PUMP WITH ELECTRIC BACK-UP HEAT USING 2-STAGE THERMOSTAT WITH DEHUMIDIFICATION

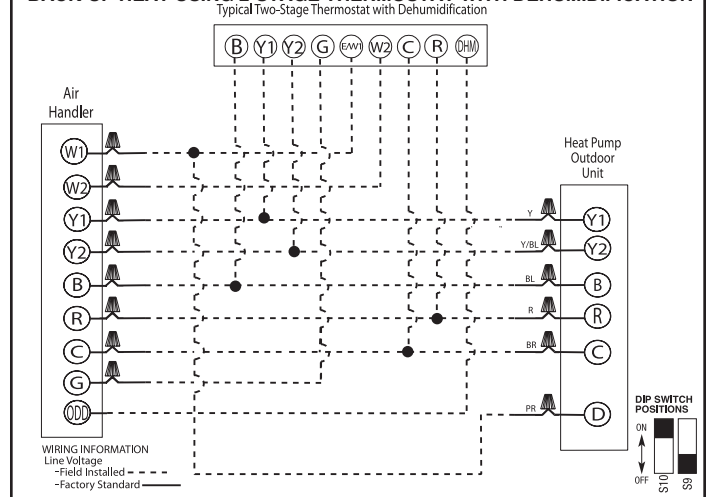
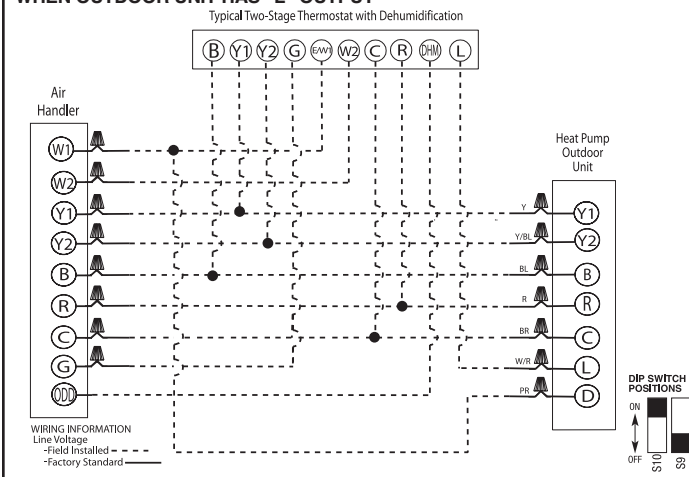

FIGURE 28
2-STAGE HEAT PUMP WITH ELECTRIC BACK-UP HEAT USING 2-STAGE THERMOSTAT WITH DEHUMIDIFICATION AND A MALFUNCTION LIGHT WHEN OUTDOOR UNIT HAS "L" OUTPUT



3.13 AIRFLOW

The (-)H1V and (-)H2V air-handlers have variable speed electronically commutated motors (ECM) which deliver a near constant level of air-flow up to an external static pressure of 1.0" W.C. Air-flow settings must be configured in the field using DIP switches located on the ECM Motor Interface Control Board to assure proper air-flow is delivered for the particular system being installed. Refer to the table in Section 3.13.1 below for general air-flow operating limits. DIP switches are also provided on the control board to configure the available dehumidification options should enhanced dehumidification be desired. The following sections provide details on configuring these DIP switches for specific applications.

3.13.1 GENERAL AIRFLOW OPERATING LIMITS

Cabinet Width	17/21		17/21		21			24	
	18 1.5	24 2	30 2.5	36 3	42 3.5	48 4	60 5	48 4	60 5
Cooling BTUH x 1,000 Cooling Tons Nominal									
Heat Pump or Air Conditioning Maximum Heat/Cool CFM [L/s] (37.5 CFM [18 L/s]/1,000 BTUH) (450 CFM [212 L/s]/Ton Nominal)	675 [319]	900 [425]	1125 [531]	1350 [637]	1575 [743]	1800 [850]	1925 [907]	1800 [850]	1930* [911]
Heat Pump or Air Conditioning Nominal Heat/Cool CFM [L/s] (33.3 CFM [16 L/s]/1,000 BTUH) (400 CFM [189 L/s]/Ton Nominal)	600 [283]	800 [378]	1000 [472]	1200 [566]	1400 [661]	1600 [755]	1750 [826]	1600 [755]	1800* [850]
Heat Pump or Air Conditioning Minimum Heat/Cool CFM [L/s] (30.0 CFM [14 L/s]/1,000 BTUH) (360 CFM [170 L/s]/Ton Nominal)	540 [255]	720 [340]	900 [425]	1080 [510]	1260 [595]	1440 [680]	1575 [743]	1440 [680]	1620* [765]
Maximum kW Electric Heating & Minimum Electric Heat CFM [L/s]	13 487 [230]	13 617 [291]	18 814 [384]	18 1054 [497]	20 1171 [553]	25 1502 [709]	25 1502 [709]	25 1502 [709]	1666 [786]
Maximum Electric Heat Rise °F [°C]	80 [26.7]	63 [17.2]	66 [18.9]	51 [10.6]	49 [9.4]	50 [10]	50 [10]	50 [10]	54 [12.2]

*CFM [L/s] per ton requirements are reduced for 5 ton systems.

3.13.2 ECM MOTOR INTERFACE CONTROL BOARD OVERVIEW

The ECM Motor Interface Control Board is provided to control the variable speed ECM blower motor & electric heat operation based on the room thermostat and humidistat inputs. The control board is located inside the control box that is attached to the blower housing. A bank of 10 DIP switches is provided on the control board for motor CFM changes and to enable various dehumidification modes. Figures 29 and 30 below indicate the function, relative location, and factory position of the DIP switches. Sections 3.13.3 - 3.13.10 below provide details on how to set the DIP switches to achieve the desired air-flow levels, how to enable the enhanced dehumidification modes, and how to determine the approximate indoor CFM using the flashing on-board LED. (See Section 5.1 for additional details on the ECM Motor Interface Control Board)

IMPORTANT: Line voltage electrical power must be disconnected from the air-handler for DIP switch setting changes to take effect. Even if the motor is not operating, the motor will not recognize changes in DIP switch positions until power is removed and then restored to the air-handler.

FIGURE 29
DIP SWITCH FUNCTIONS

Switch	Function
1 & 2	Cooling Heat Pump Airflow Settings
3 & 4	Cooling Heat Pump Airflow Trim Adjustment
5 & 6	Heat Airflow Settings
7 & 8	Passive Dehumidification Profile Selection
9 & 10	Dehumidification Mode Selection

NOTE: All DIP switches are shipped from the factory in the OFF position except for switch 9 which is shipped in the ON position.

FIGURE 30
DIP SWITCH FACTORY SETTINGS

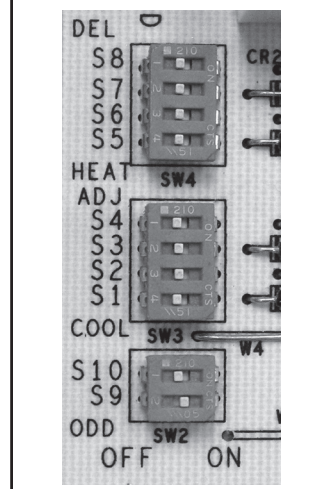

3.13.3 COOLING/HEAT PUMP HEATING MODE AIR-FLOW SETTINGS (SEE FIGURES 30A & 30B)

The (-)H1V and (-)H2V non-communicating-series of air handlers allow a wide range of airflow settings for cooling and heat pump operation. These airflow settings are selected via DIP switches 1 and 2 on the interface board. DIP switches 1 and 2 allow the user to tailor the airflow for the particular installation. The switches are factory set to profile A. (See Figures 31A and 31B)

NOTE: If supplemental heat is energized during the heat pump heating mode, the electric heat air-flow setting will override the heat pump heating CFM setting and the indoor air-flow will go to the CFM selected by DIP switches 5 and 6. (See Section 3.13.4)

FIGURE 31A
FACTORY AIR-FLOW SETTINGS FOR SWITCHES 1 AND 2: (-)H1V (SINGLE-STAGE)

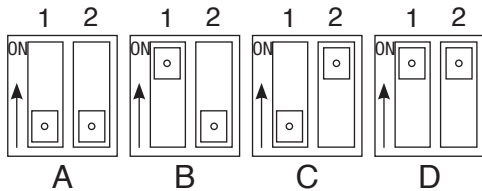

NOTE: With no dehumidification;
switch 9 “ON” (factory default)

(-)H1V COOLING/HEAT PUMP HEATING NOMINAL AIR-FLOW CFM [L/s]										
PROFILE SELECTION	SWITCH 1 POSITION	SWITCH 2 POSITION	(-)H1V2417S 2 TON	(-)H1V3617S 3 TON	(-)H1V3621M (-)H1V3621H 3 TON	(-)H1V4821S 4 TON	(-)H1V4821M 4 TON	(-)H1V4824S 4 TON	(-)H1V6021S 5 TON	(-)H1V6024S 5 TON
			Y1 or Y2	Y1 or Y2	Y1 or Y2	Y1 or Y2	Y1 or Y2	Y1 or Y2	Y1 or Y2	Y1 or Y2
A *	OFF	OFF	850 [401]	1200 [566]	1200 [566]	1575 [743]	1625 [767]	1800 [850]	1700 [802]	1800 [850]
B	ON	OFF	850 [401]	1200 [566]	1200 [566]	1575 [743]	1625 [767]	1800 [850]	1800 [850]	1800 [850]
C	OFF	ON	650 [307]	1000 [472]	1000 [472]	1400 [661]	1425 [673]	1625 [767]	1600 [755]	1600 [755]
D	ON	ON	650 [307]	1000 [472]	1000 [472]	1400 [661]	1425 [673]	1625 [767]	1600 [755]	1600 [755]

* FACTORY SETTING

FIGURE 31B
FACTORY AIR-FLOW SETTINGS FOR SWITCHES 1 AND 2: (-)H2V (2-STAGE)

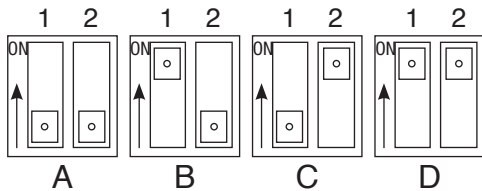

NOTE: With no dehumidification;
switch 9 “ON” (factory default)

(-)H2V COOLING/HEAT PUMP HEATING NOMINAL AIR-FLOW CFM [L/s]												
SELECTION (ONE OF THE PAIRS)	SWITCH 1 POSITION	SWITCH 2 POSITION	(-)H2V2421M 2 TON		(-)H2V3621M 3 TON		(-)H2V4821M 4 TON		(-)H2V6024S 5 TON		(-)H2V2417S 2 TON	
			Y1	Y2	Y1	Y2	Y1	Y2	Y1	Y2	Y1	Y2
A*	OFF	OFF	625 [295]	825 [389]	875 [413]	1225 [578]	1225 [578]	1650 [779]	1325 [625]	1725 [814]	600 [283]	800 [377]
B	ON	OFF	625 [295]	825 [389]	875 [413]	1225 [578]	1225 [578]	1650 [779]	1325 [625]	1725 [814]	750 [253]	1000 [472]
C	OFF	ON	475 [224]	625 [295]	725 [342]	1000 [472]	1075 [507]	1450 [684]	1250 [590]	1625 [767]	450 [212]	600 [283]
D	ON	ON	475 [224]	625 [295]	725 [342]	1000 [472]	1075 [507]	1450 [684]	1250 [590]	1625 [767]	450 [212]	600 [283]

*FACTORY SETTINGS

3.13.4 ELECTRIC HEAT AIR-FLOW SETTINGS

The air-flow level delivered anytime the electric heater is energized can be adjusted independently from the cooling/heat pump air-flow level using DIP switches 5 and 6. Since the air-handlers are shipped from the factory to deliver adequate airflow for the maximum recommended kW of electric heat, the discharge air temperature may be too low and uncomfortable in applications where a much lower kW heater is installed. This can be remedied by reducing the electric heat air-flow through changes to the positions of DIP switches 5 and 6. (See Figures 32A and 32B for options)

NOTE: If supplemental heat is energized during the heat pump heating mode, the electric heat air-flow setting will override the heat pump heating CFM setting and the indoor air-flow will revert to the CFM selected by DIP switches 5 and 6.

IMPORTANT: The +/- 10% air-flow trim adjustment described in Section 3.13.5 below affects the electric heat air-flow level by the same percentage.

FIGURE 32A
AIR-FLOW SETTINGS FOR SWITCHES 5 AND 6 (-)H1V

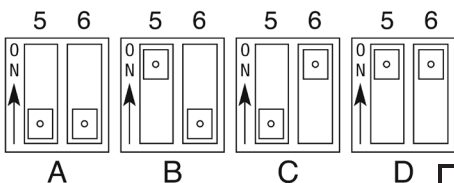

MINIMUM AIR-FLOW PER kW	
3 kW to 13 kW	= 600 min. CFM
15 kW to 18 kW	= 800 min. CFM
20 kW to 25 kW	= 1400 min. CFM
30 kW	= 1800 min. CFM

PROFILE SELECTION	SWITCH 1 POSITION	SWITCH 2 POSITION	(-)H1V ELECTRIC HEAT NOMINAL AIR-FLOW CFM [L/s]				
			(-)H1V2417S 2 TON	(-)H1V36(---) 3 TON	(-)H1V4821(-) 4 TON	(-)H1V4824S/ (-)H1V6024S 4/5 TON	(-)H1V6021S 5 TON
A *	OFF	OFF	800 [378]	1200 [566]	1600 [755]	1800 [850]	1700 [802]
B	ON	OFF	600 [283]	600 [283]	800 [378]	800 [378]	800 [378]
C	OFF	ON	600 [283]	1000 [472]	1400 [661]	1600 [755]	1600 [755]
D	ON	ON	600 [283]	600 [283]	800 [378]	800 [378]	800 [378]

* FACTORY SETTING

FIGURE 32B
AIR-FLOW SETTINGS FOR SWITCHES 5 AND 6 (-)H2V

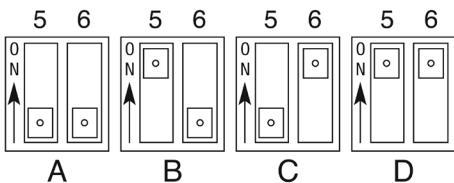

MINIMUM AIR-FLOW PER kW	
3 kW to 13 kW	= 600 min. CFM
15 kW to 18 kW	= 800 min. CFM
20 kW to 25 kW	= 1400 min. CFM
30 kW	= 1800 min. CFM

SELECTION (ONE OF THE PAIRS)	SWITCH 1 POSITION	SWITCH 2 POSITION	(-)H2V COOLING/HEAT PUMP HEATING NOMINAL AIR-FLOW CFM [L/s]				
			(-)H2V2421M 2 TON	(-)H2V3621M 3 TON	(-)H2V4821M 4 TON	(-)H2V6024S 5 TON	(-)H2V2417S 2 TON
A*	OFF	OFF	800 [378]	1200 [566]	1600 [755]	1725 [814]	800 [378]
B	ON	OFF	600 [283]	600 [283]	800 [378]	800 [378]	1000 [472]
C	OFF	ON	600 [283]	1000 [472]	1400 [661]	1600 [755]	600 [283]
D	ON	ON	600 [283]	600 [283]	800 [378]	800 [378]	600 [283]

*FACTORY SETTINGS

3.13.5 AIR-FLOW TRIM ADJUSTMENT

Cooling and heating CFM may be adjusted by +10% or -10% from nominal CFM using DIP switches 3 and 4. Refer to Figure 33 below for DIP switch settings to achieve the desired trim adjustment.

IMPORTANT: Cooling, heat pump heating, and electric strip heating CFM will all be affected by this adjustment.

NOTE: If an Air-Flow Trim Adjustment of -10% is selected, the additional 10% reduction in CFM will be ignored if cooling mode dehumidification is being called for by the Passive or Active (On-Demand) Dehumidification functions.

NOTE: Continuous fan CFM is **not** affected by the Air-Flow Trim Adjustment and will remain at 50% of the nominal CFM selected by DIP switches 1 and 2. (See Section 3.13.3)

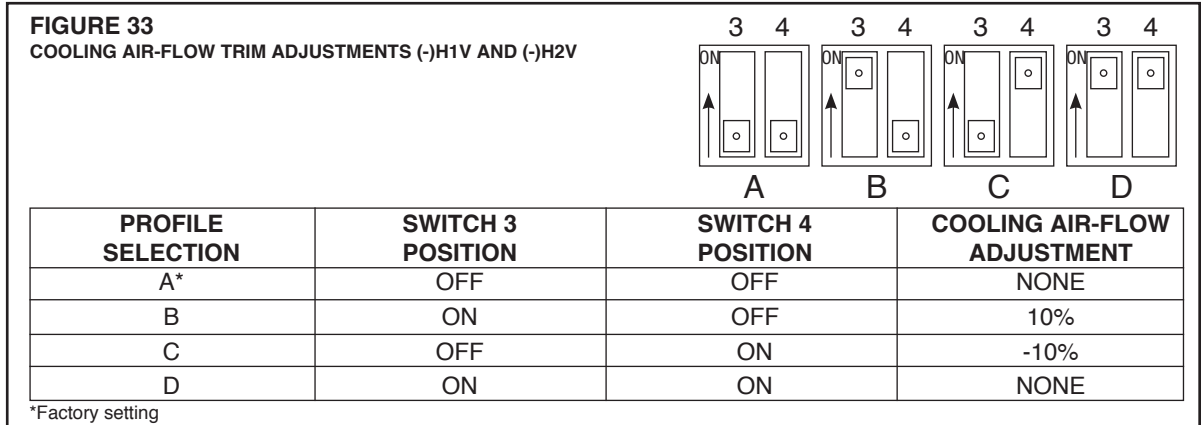

3.13.6 MOTOR OFF-DELAY & SOFT START/STOP

The variable speed ECM motor is shipped from the factory to provide a 30 second blower off-delay at the end of a call for cooling or heat pump heating. The variable speed ECM motor also features a soft start and stop to make start-up and shut down less noticeable. The motor ramps up and ramps down gradually over a 15 second period.

3.13.7 COOLING MODE ENHANCED DEHUMIDIFICATION OVERVIEW

While rated or nominal air-flow levels provide adequate cooling mode dehumidification in dry and moderately humid climates, dehumidification may not be adequate in climates with above average humidity. The (-)H1V and (-)H2V air-handlers have multiple enhanced dehumidification options that can be enabled and configured using DIP switches 7 – 10 on the ECM Motor Interface Control Board. There are two possible approaches to enhanced dehumidification, Passive and Active (On-Demand) Dehumidification. Passive Dehumidification relies on pre-programmed reduced air-flow profiles and is active during every cooling cycle regardless of the actual indoor humidity. Active (On-Demand) Dehumidification allows automatic dehumidification only as needed and requires a room humidistat or a room thermostat with built-in dehumidification (dehumidifying thermostat) to notify the air-handler controls to reduce the indoor air-flow by a set amount when the indoor humidity exceeds the humidity set-point. Sections 3.13.8 and 3.13.9 below provide details on how each of these approaches to dehumidification work. The air-handlers are shipped from the factory with the enhanced dehumidification disabled. (See Figure 34)

NOTE: Reduced air-flow dehumidification is disabled when heat pumps are operating in the heating mode.

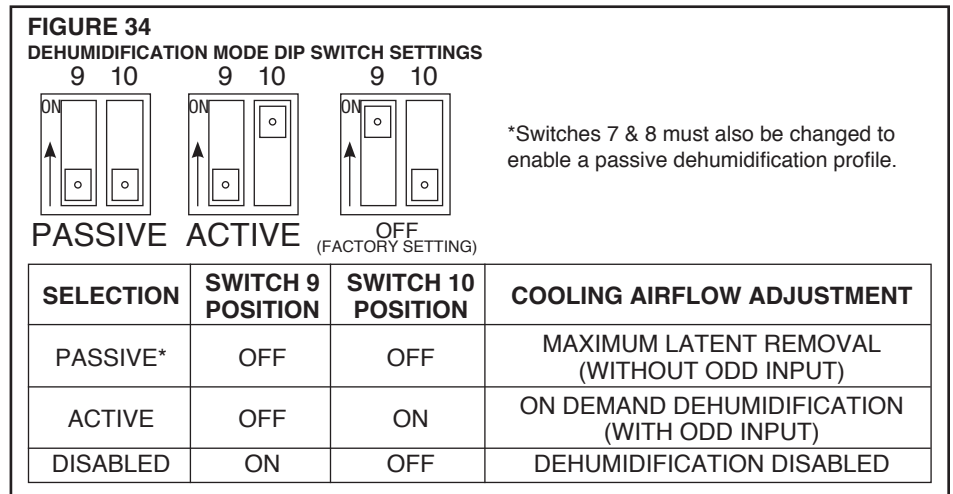

3.13.8 PASSIVE DEHUMIDIFICATION SETTINGS

Passive dehumidification utilizes 3 possible enhanced air-flow profiles (See Figures 35 & 36) that reduce the air-flow level significantly for a period of time at start-up which lowers the indoor coil surface temperature. The reduced indoor coil surface temperature increases the amount of moisture condensing on the coil surface and thus increases dehumidification of the air being drawn through the coil. The air-flow will be ramped up to 100% in various amounts and various time periods depending on the profile selected using DIP switches 7 & 8. If passive dehumidification is desired, select the appropriate profile based on the level of dehumidification required using DIP switches 7 and 8 (See Figure 35 & 36) and be sure DIP switches 9 and 10 are both switched to the OFF position to enable the Passive Dehumidification Mode. (See Figure 34)

NOTE: The LED on the ECM Motor Interface Control Board will flash a code indicating the air-flow to the nearest 50 CFM at any given time which can be used to confirm the air-flow when the system is in the enhanced dehumidification mode. (See Section 3.13.10)

NOTE: If the Cooling/Heating Air-Flow Trim Adjustment has been set to -10% (See Section 3.13.5), the -10% adjustment will be ignored during the passive dehumidification ramp up period and the reduction in air-flow during the ramp up period will be based on the nominal air-flow selected by DIP switches 1 and 2. (See Figures 31A and 31B) This is done to keep the indoor air-flow at a safe minimum level.

IMPORTANT: Switching DIP switches 9 and 10 both to the OFF position disables any input to the ODD terminal on the control board. If a humidistat or a dehumidifying thermostat is to be used for enhanced dehumidification, leave DIP switches 7 and 8 in the OFF position (factory position) and refer to Figure 34 above and Section 3.13.9 below and to enable the Active (On-Demand) Dehumidification Mode.

IMPORTANT: Be sure to check for correct air-flow and refrigerant charge levels with Passive Dehumidification disabled. For 2-stage systems using (-)H2V air-handlers, be sure the thermostat is set so 2nd stage air-flow and compressor operation is energized when checking air-flow and refrigerant charge levels.

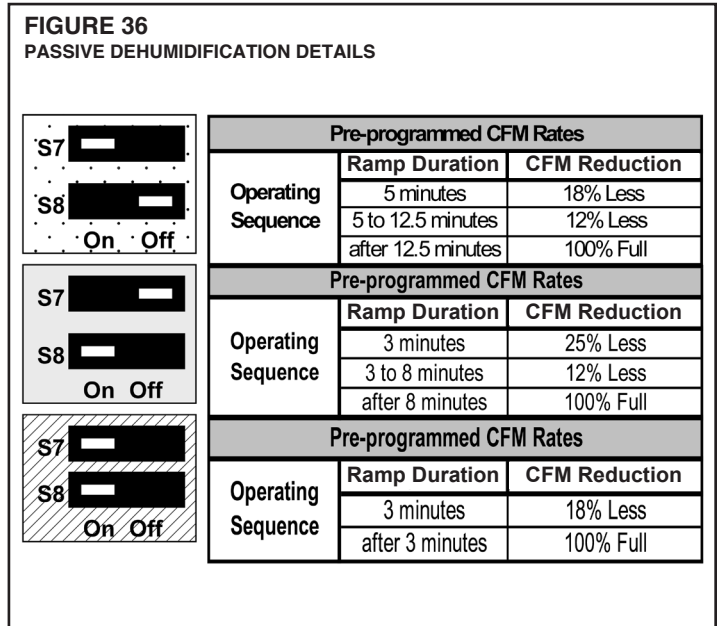
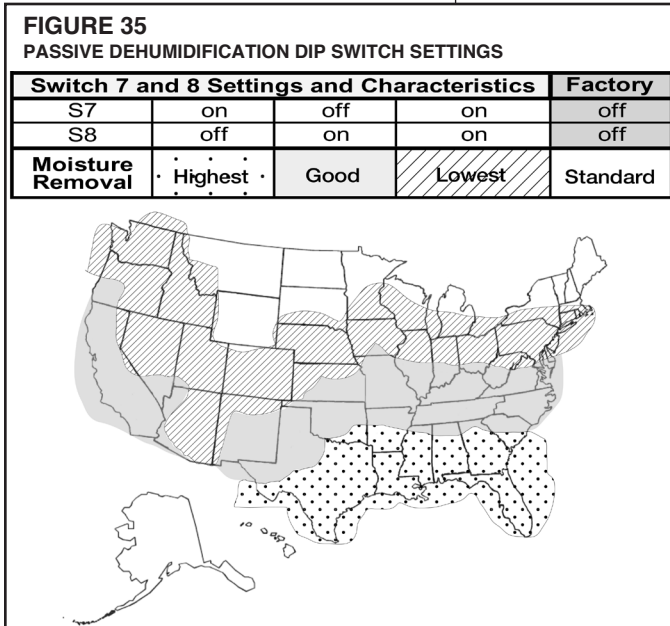

3.13.9 ACTIVE (ON-DEMAND) DEHUMIDIFICATION SETTINGS

Active (On-Demand) Dehumidification relies on an input from a room humidistat or dehumidifying thermostat to the ODD (on-demand dehumidification) terminal on the ECM Motor Interface Control Board to reduce the indoor air-flow by 15% to accomplish increased dehumidification when the humidity level in the conditioned space exceeds the humidity set-point. A thermostat pigtail is provided on the exterior of the air-handler cabinet along with the other thermostat pigtails that is connected to the ODD terminal on the control board and should be used to connect the dehumidification input from the humidistat or dehumidifying thermostat.

If Active (On-Demand) Dehumidification is desired, select the appropriate profile for DIP switches 9 and 10 (See Figure 34).

IMPORTANT: An input from a humidistat or dehumidifying thermostat must be connected to the ODD thermostat pigtail (Green/Yellow) when DIP switches 9 and 10 are switched to the "ACTIVE" position. Otherwise, indoor air-flow will always be reduced by 15% in the cooling mode.

If Active (On-Demand) Dehumidification is enabled and humidity in the conditioned space is below the humidity set-point on the humidistat or dehumidifying thermostat, a 24VAC input is applied to the ODD terminal on the control board. (See Figure 37) This will cause the indoor blower motor to operate at the nominal air-flow selected by

DIP switches 1 and 2 (See Figures 31A and 31B) or the nominal air-flow that has been adjusted using the air-flow trim adjustment selected by DIP switches 3 and 4. (See Figure 33)

If the humidity in the conditioned space is above the humidity set-point on the humidistat or dehumidifying thermostat, the input to the ODD terminal on the control board is 0 VAC (See Figure 37) which causes the indoor air-flow to be reduced by 15% of the nominal air-flow selected by DIP switches 1 and 2. The reduced air-flow lowers the indoor coil surface temperature and increases the amount of moisture condensing on the coil surface, thus increasing dehumidification of the air being drawn through the coil.

NOTE: If the Cooling/Heating Air-Flow Trim Adjustment has been set to -10% (See Section 3.13.5), the -10% adjustment will be ignored when the humidistat or dehumidifying thermostat is calling for enhanced dehumidification and the indoor air-flow will be 15% below the nominal air-flow selected by DIP switches 1 and 2 to keep the indoor air-flow at a safe minimum level.

NOTE: The LED on the ECM Motor Interface Control Board will flash a code indicating the air-flow to the nearest 50 CFM at any given time which can be used to confirm the air-flow when the system is in the enhanced dehumidification mode. (See Section 3.13.10)

NOTE: Refer to the **Typical Thermostat and Control Wiring (Section 3.12.9)** for recommended wiring connections for humidistats and dehumidifying thermostats.

IMPORTANT: A humidistat can be used for enhanced cooling dehumidification only if it is of the type where the contacts close when the humidity in the conditioned space is above the set-point. Dehumidistat 41-25066-02 can also be used since its contacts close when the humidity is above the set-point. Typical dehumidistats are not compatible with this system as their contacts open when the humidity is below the set-point. Only dehumidifying thermostats that supply 24VAC at the DHM terminal when the humidity is above the set-point can be used with this system.

IMPORTANT: Be sure to check for correct air-flow and refrigerant charge levels with Active (On-Demand) Dehumidification disabled. For 2-stage systems using (-)H2V air-handlers, be sure the thermostat is set so 2nd stage air-flow and compressor operation is energized when checking air-flow and refrigerant charge levels.

3.13.10 USING THE ON-BOARD LED TO DETERMINE BLOWER CFM

The (-)H1V and (-)H2V ECM interface control board LED (see Figure 38) indicates blower output by flashing one (1) second for every 100 CFM. The LED will pause 1/10 second between each flash. After the blower CFM has been displayed, the LED will illuminate dimly for 10 seconds before repeating the sequence. (See Figure 39.)

NOTE: If air-flow is not a multiple of 100 CFM, the last LED flash is a fraction of a second in 50 CFM increments.

FIGURE 37
ODD TERMINAL FUNCTIONS

INDOOR AMBIENT CONDITION	INPUT TO "ODD" TERMINAL (FROM HUMIDISTAT)
HIGH HUMIDITY	0 VAC
LOW HUMIDITY	24 VAC

FIGURE 39
LED FLASH CODES

INTERFACE BOARD DIP SWITCH SETTINGS	SOME EXAMPLES OF LED OUTPUT
1200 CFM	<ul style="list-style-type: none"> Flashes 12 times Illuminate dimly 10 seconds, repeat sequence
600 CFM	<ul style="list-style-type: none"> Flashes 6 times Illuminate dimly 10 seconds, repeat sequence
950 CFM	<ul style="list-style-type: none"> Flashes 9 times, flash once for 1/2 second Illuminate dimly 10 seconds, repeat sequence

FIGURE 38
ECM MOTOR INTERFACE CONTROL BOARD

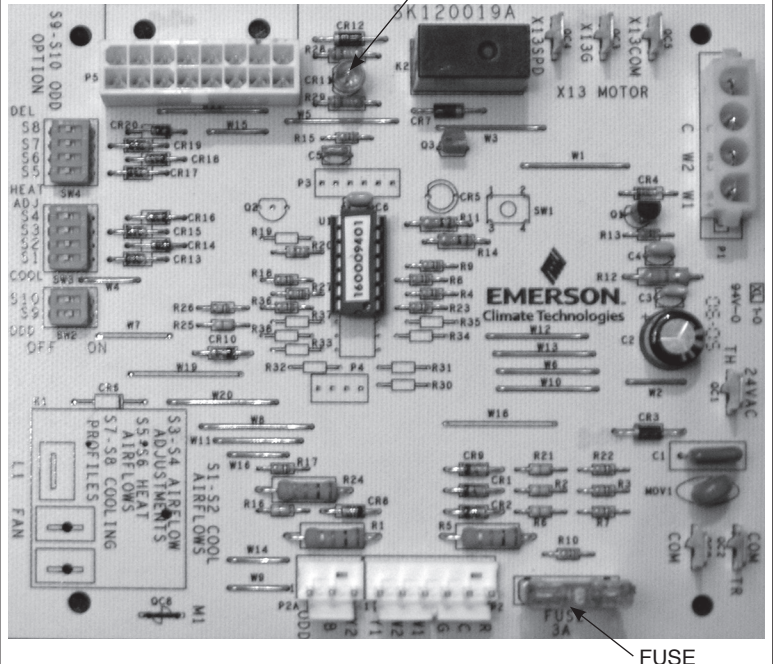

4.0 START-UP

4.1 PRE-START CHECKLIST

PRE-START CHECKLIST

<input type="checkbox"/> YES <input type="checkbox"/> NO	Is unit properly located, level, secure and service-able?
<input type="checkbox"/> YES <input type="checkbox"/> NO	Has auxiliary pan been provided under the unit with separate drain? (Units installed above a finished ceiling).
<input type="checkbox"/> YES <input type="checkbox"/> NO	Is condensate line properly sized, run, trapped, pitched and tested?
<input type="checkbox"/> YES <input type="checkbox"/> NO	Is ductwork correctly sized, run, taped and insulated?
<input type="checkbox"/> YES <input type="checkbox"/> NO	Have all cabinet openings and wiring been sealed with caulking?
<input type="checkbox"/> YES <input type="checkbox"/> NO	Is the filter clean, in place and of adequate size?
<input type="checkbox"/> YES <input type="checkbox"/> NO	Is the wiring tight, correct and to the wiring diagram?
<input type="checkbox"/> YES <input type="checkbox"/> NO	Is the unit properly grounded and protected (fused)?
<input type="checkbox"/> YES <input type="checkbox"/> NO	Is the thermostat heat anticipator been set properly?
<input type="checkbox"/> YES <input type="checkbox"/> NO	Is the unit circuit breaker(s) rotated properly "on" up - "off" down?
<input type="checkbox"/> YES <input type="checkbox"/> NO	Are the unit circuit breaker(s) line lug cover(s) in place?
<input type="checkbox"/> YES <input type="checkbox"/> NO	Are all access panels in place and secure?

Refer to outdoor unit installation instructions for system start-up instructions and refrigerant charging instructions.

4.2 SYSTEM START-UP AND OPERATIONAL CHECK-OUT

After the air-handler and other system components have been installed and the Pre-Start Checklist has been completed, the system should be started up and an operational check-out should be performed. The operational check-out includes checking sequence of operation of the controls, air-flow, and refrigerant charge. If the controls are not found to be functioning properly, or the air-flow or refrigerant charge are not within specifications, corrective action must be taken. The following sections are provided to assist the installer with the operational check-out.

4.3 SEQUENCE OF OPERATION

4.3.1 COOLING MODE

For (-)H1V models, when the thermostat calls for cooling, the G and Y1 terminals on the ECM Motor Interface Control Board are energized which causes the indoor blower to operate at the selected cooling/heat pump heating CFM and circulate air through the air-handler and duct system during the cooling cycle.

For (-)H2V models, when a 2-stage thermostat calls for 1st stage cooling, the G and Y1 terminals on the ECM Motor Interface Control Board are energized which causes the indoor blower to operate at the selected 1st stage cooling/heat pump CFM. Should the 2-stage thermostat call for 2nd stage cooling operation, Y2 terminal on the control board is also energized which causes the indoor motor to operate at the selected 2nd stage CFM. As the 2-stage thermostat cycles between the 1st and 2nd stages, the motor will cycle between 1st and 2nd stage CFM as directed by the control board.

When the thermostat call for cooling is satisfied or is turned to the off position, the G, Y1, and Y2 terminals on the ECM Motor Interface Control Board are de-energized. A time delay programmed into the blower control board keeps the blower motor energized for an additional 30 seconds to extract the residual cooling from the cold indoor coil.

NOTE: See Section 3.13.3 for cooling air-flow settings.

4.3.2 ELECTRIC HEAT MODE

When the thermostat calls for the 1st stage of heat, the W1 terminal on the ECM Motor Interface Control Board is energized. This energizes the indoor blower motor and all of the electric heater elements for heater kits with 10kW of heat or less and the 1st stage elements for 13kW heater kits and higher. The indoor blower will operate at the selected electric heat CFM. If W1 and W2 thermostat pigtailed at the air-handler are wired together on 13kW heater kits and higher, all of the elements to be energized. For 13kW heater kits and higher, a 2-stage heat thermostat can be used to energize the W2 terminal on the control board upon a call for a 2nd stage of heat which will in turn will energize the 2nd stage heater elements. Both (-)H1V and (-)H2V air-handlers always operate at a single CFM in the electric heat mode regardless of the number of electric heat stages that are energized. The electric heater will cycle between the 1st and 2nd stages of heat at the direction of the thermostat. When the thermostat call for heat is satisfied or turned to the off position, the W1 and W2 terminals on the control board are de-energized which will de-energize the heating elements in 30-60 seconds as the bimetallic disc in the sequencer cools. The blower motor will be de-energized 75 seconds after the call for heat ends to allow time for the heating elements to be de-energized.

NOTE: See Section 3.13.4 for electric heat air-flow settings.

4.3.3 HEAT PUMP HEATING MODE

When the heat pump thermostat is set to "heat" mode, the "B" terminal on the outdoor unit is energized which energizes the reversing valve and switches it to the heating position. When the thermostat calls for heat, the thermostat energizes the G and Y1 terminal on the ECM Motor Interface Control Board which causes the indoor blower to operate at the selected cooling/heat pump heating CFM. (See Section 3.13.3) The indoor blower will then begin to circulate air through the air-handler and duct system during the heating cycle.

For (-)H2V models, when a 2-stage thermostat energizes the G and Y1 terminals on the control board, the indoor blower motor will operate at the selected 1st stage cooling/heat pump heating CFM corresponding to 1st stage heat pump operation of the system. Should the 2-stage thermostat call for 2nd stage heat pump operation, Y2 terminal on the control board is also energized which causes the blower to operate at the selected 2nd stage cooling/heat pump CFM. As the 2-stage thermostat cycles between the 1st and 2nd stages, the blower will cycle between 1st and 2nd stage CFM as directed by the control board.

Should the room temperature continue to fall when the system is operating in the heat pump heating mode, the thermostat energizes the W2 terminal on the control board which energizes supplemental electric heat. The compressor and mechanical heating will continue to operate simultaneously with the supplemental electric heat. For 13kW heater kits and larger, the W1 and W2 pigtailed on the (-)H1V can be connected together for maximum 2nd stage supplemental heat or connected independently to the W1 and W2 terminals on the thermostat to provide a 3rd stage of heat as needed. For (-)H2V models, the supplemental heat would be the 3rd stage of heat if W1 and W2 are wired together and 3rd and 4th stage if W1 and W2 are connected to the W1 and W2 terminals on the thermostat independently.

When the thermostat heating call is satisfied, the G, Y1, and Y2 terminals on the control board are de-energized. A time delay programmed into the ECM variable speed motor keeps the blower motor energized for an additional 30 seconds to extract the residual heat from the warm indoor coil.

NOTE: If supplemental heat is energized during the heat pump heating mode, the electric heat air-flow setting will override the heat pump heating CFM setting and the indoor air-flow will go to the CFM selected by DIP switches 5 and 6. (See Section 3.13.4)

4.3.4 SUPPLEMENTAL ELECTRIC HEAT DURING DEFROST (HEAT PUMP)

Supplemental electric heat during the defrost cycle can be provided by running a wire from the purple pigtail wire (from D terminal on defrost control) on the outdoor heat pump unit to the W1 pigtail on the air-handler. This will energize the electric heat during the defrost cycle to prevent cold air from being discharged from the supply registers in the home.

For the most economical operation and if cold discharge air is not a concern, do not run the wire from the purple pigtail on the outdoor unit to the W1 pigtail on the air-handler. In this case, supplemental heat will only be energized if the thermostat energizes the 2nd stage of heat during the defrost cycle due to a significant drop in room temperature.

4.3.5 EMERGENCY HEAT (HEAT PUMP)

If heat pump thermostat is set to the "Emergency Heat" mode, the outdoor unit will be prevented from operating and heat will be provided solely by the electric heater. The electric heater elements and indoor blower motor will be energized any time there is a call for heat with no compressor and outdoor fan operation. A jumper should be installed between the W1 and E terminals on the thermostat sub-base so a call for emergency heat will be transferred to the 1st stage of heat of the thermostat. The indoor blower will cycle on and off with the electric heater elements when the thermostat fan setting is set to the "auto" mode, although there will be a 75 second delay off period for the blower motor after a call for heat ends.

4.3.6 THERMOSTAT FAN SETTING

If the thermostat “FAN” setting is adjusted to the “AUTO” position, the indoor blower motor will only operate when there is a call for cooling or heating. If the setting is adjusted to the “ON” position, the indoor blower motor will operate continuously. The indoor blower motor will operate at 50% of the maximum cooling CFM selected by DIP switches 1 and 2 (see Section 3.13.3) when there is no call for cooling and heating to reduce power consumption and noise.

4.4 CORRECTING ELECTRIC HEAT kW FOR VOLTAGE

The actual electric heat kW varies with the supply voltage. Use the following formula to correct the heater rated kW at voltages other than rated voltage.

$$\text{Actual kW} = \text{Rated kW} \times (\text{Actual Voltage}^2 / \text{Rated Voltage}^2).$$

4.5 CALCULATING ELECTRIC HEAT CAPACITY IN BTUH

Use the following formula to convert heater kW to heating capacity in BTUH.

$$\text{BTUH Capacity} = \text{kW} \times 3412$$

(Where 3412 = BTUH per kW)

4.6 CHECKING INDOOR AIR-FLOW

4.6.1 USING THE ON-BOARD LED TO DETERMINE BLOWER CFM

An LED on the ECM Motor Interface Control Board flashes to indicate air-flow to the nearest 50 CFM and is by far the easiest method for approximating the blower CFM. See Section 3.13.10 for details.

4.6.2 ESTIMATING CFM USING ELECTRIC HEAT TEMPERATURE RISE

If the air-handler is equipped with an electric heater, the CFM can be estimated using the air temperature rise across the air-handler with the heater and blower both energized once the unit has run long enough for the temperatures to stabilize. As with determining CFM using external static pressure, the CFM determined by this method is an estimate, but is accurate enough for all practical purposes. Measure the return air temperature as close to the unit as possible and the supply air temperature about half way from the air-handler to the first elbow or end of the supply plenum. Use the following formula to calculate CFM once the temperature rise is determined.

$$\text{CFM} = \text{Heating BTUH} / (\text{Elevation Factor} \times \text{Temp Rise } ^\circ\text{F})$$

Note: Refer to Section 4.5 to determine Heating BTUH and the following chart for Elevation Factor.

Elevation (Feet)	Elevation Factor
Sea Level	1.08
500	0.98
1000	0.96
1500	0.95
2000	0.93
2500	0.91
3000	0.90
3500	0.88
4000	0.86
5000	0.83
6000	0.83
7000	0.77
8000	0.74
9000	0.72
10000	0.69

4.7 CHECKING REFRIGERANT CHARGE

System refrigerant charging should only be performed after the indoor air-flow is confirmed to be correct for the application. Once the air-flow is confirmed, refer to the manufacturer’s outdoor unit charging chart and installation manual for the proper charging procedure for the system.

5.0 COMPONENTS & CONTROLS

5.1 ECM MOTOR INTERFACE CONTROL BOARD

An ECM Motor Interface Control Board is provided to control the variable speed ECM blower motor & electric heat operation based on the room thermostat and humidistat inputs. The control board is located inside the control box that is attached to the blower housing. The control board has the following features.

- A bank of 10 DIP switches is provided on the control board for motor CFM changes and to enable various dehumidification modes (See Sections 3.13.3 through 3.13.9).

IMPORTANT: Line voltage electrical power must be disconnected from the air-handler for DIP switch setting changes to take effect. Even if the motor is not operating, the motor will not recognize changes in DIP switch positions until power is removed and then restored to the air-handler.

- The control has an on-board 3 amp automotive style fuse to protect the control circuit.
- An LED provided on the control board flashes to indicate approximate indoor air-flow in 50 CFM increments.
- A plug on the electric heater kit wiring harness plugs into a 4 pin plug receptacle on the control board to allow control of the electric heater by the control board based on thermostat input.
- The thermostat pigtail harness connects to a 9-pin connector on the control board. Wires from the thermostat do not connect directly to the control board, but rather to the pigtails that are routed to the exterior of the air-handler cabinet.
- There is no blower on-delay when there is a call for blower operation, but the motor speed does ramp up gradually over a 15 second period at start-up.
- There is no blower off-delay programmed into the control board when a call for cooling or heat pump heating ends since a 30 second off-delay is programmed into the variable speed ECM motor when the air-handler has been operating in the cooling or heat pump heating mode. The off-delay maximizes efficiency by extracting the residual cooling or heating capacity in the coil.
- There is no blower off-delay programmed into the control board when a call for electric heating ends since a 75 second off-delay is programmed into the variable speed ECM motor when the air-handler has been operating in the electric heat or emergency heat mode. The off-delay allows time for the contacts in the bi-metallic disc type heating sequencer to open which de-energizes the heater elements.
- Figures 29 and 30 in Section 3.13.2 indicate the function of the DIP switches, relative location of the DIP switches, and the factory switch positions. All DIP switches are shipped from the factory in the OFF position except for switch 9 which is shipped in the ON position.

5.2 VARIABLE SPEED ECM BLOWER MOTOR

All (-)H1V and (-)H2V models have electronically commutated (ECM) variable speed motors.

- The motor has a control module mounted on the end of the motor opposite the shaft end which is replaceable should only the control module itself fail.
- ECM motors do not require a run capacitor.
- CFM selections and dehumidification profiles are selectable on the ECM Motor Interface Control Board as described in Section 3.13.
- The variable speed ECM motor has a built in soft start that will ramp the motor up to speed gradually over a 15 second period.
- An off-delay is built into the control of the motor that keeps the motor energized for 30 seconds after the call for cooling or heat pump heating ends or 75 seconds after a call for electric heat ends.
- The air-flow delivery rate for the variable speed ECM motor will remain relatively constant regardless of the external static pressure until the motor reaches its torque limit at which time the CFM will begin dropping off as external static pressure continues to increase. The benefit of constant CFM is the assurance of adequate air-flow regardless of the duct system design and loading up of filters as long as the external static pressure remains at a reasonable level and the torque limit of the motor has not been exceeded.

5.3 BLOWER

The blower utilizes a forward curved centrifugal wheel. The blower housing is constructed from galvanized sheet metal. The motor is attached with a 4-arm belly band type mount that screws into the side of the blower housing. The control box attaches to the front of the blower housing for access through the blower access door. The blower slides into place on a track and is secured by 4 sheet metal screws.

5.4 TRANSFORMER

A 40VA transformer is located inside the control box attached to the blower housing which provides 24V control voltage for both the air-handler & the outdoor unit. The transformer in 208/240V models is wired from the factory for 240V applications, but has a separate 208V tap for 208V applications. The black wires connected to the 240V tap must be moved to the 208V tap when installing the air-handler in 208V applications to assure full 24V+ control voltage for reliable operation of the system controls.

5.5 INDOOR COIL ASSEMBLY

- The indoor coil slabs are a fin & tube design with enhanced aluminum fins & internally grooved aluminum tubing.
- Most models have 3 coil slabs in an “N” configuration, but some models have 2 coil slabs in an “A” configuration.
- All (-)H1V and (-)H2V air-handlers have non-bleed thermal expansion valves (TXV) for refrigerant control.
- All models have a self-draining polypropylene condensate drain pan to eliminate standing water & a painted & insulated sheet metal drip pan to catch any water drips from the coil when the air-handler is oriented in the horizontal position.
- All models have built-in sheet metal channels in various locations designed to manage condensate when the air-handler is oriented in the horizontal position, thus preventing water “blow-off”.
- Copper stubs are provided for field tubing connections.
- The coil assembly slides into the air-handler on sheet metal rails. The coil is installed in the factory for upflow & horizontal left orientations. The coil must be removed and re-installed into the air-handler cabinet 180° from its factory orientation. An additional set of coil support rails must be installed before the coil can be re-installed. The additional set of rails are included with the air-handler for field installation. (See Section 3.2.2)
- The TXV sensing bulb is shipped unattached & must be securely attached to the vapor line with the supplied clamp and insulated with the supplied foam insulation. (See Section 3.9)

6.0 ACCESSORIES & KITS

6.1 ELECTRIC RESISTANCE HEATER KITS

- All (-)H1V & (-)H2V models are shipped without electric resistance heat.
- Electric heat kits ranging from 3kW to 30kW are available for field installation.
- Refer to Sections 3.12.5, 3.12.6, & 3.12.7 for electric heat kit model numbers available for specific air-handler models along with electrical ratings & additional information regarding the heater kits.
- Heater kit installation instructions are provided with the heater kit.
- All heater kits utilize open wire nickel chromium heating elements.
- An automatic reset over-temperature limit is provided to shut off the heater elements should air-flow become too restricted or if the blower motor fails.
- 13kW kits and larger are designed to operate in 2-stage heat mode if so desired or can be operated as single stage if the W1 & W2 thermostat pigtailed are wired together.
- 208/240V single-phase (“J” Voltage) and 208/240V 3-phase (“C” Voltage) heater kits are available.
- 208/240V 3-phase (“C” Voltage) heater kits must be installed in “J” Voltage air-handlers since there are no “C” Voltage air-handlers available. “C” voltage heater kits are for 3-phase applications and allow for smaller wire & fuse/breaker size compared to single-phase “J” Voltage heater kits.
- The heater kit is controlled by the blower control based on thermostat inputs.
- All heater kits are available with a circuit breaker style disconnect.
- 10kW heater kits and smaller are also available with either a pull-out style disconnect or with no disconnect.
- Incoming electric power is connected directly to the heater kit power terminals.
- The heater kit is provided with 2 power wires that connect to the air-handler power terminal block, providing power to operate the blower motor and controls.
- The heater kit is also provided with a 4-pin connector that plugs into a mating plug on the blower control to allow the control of the heater based on thermostat inputs.

6.2 JUMPER BAR KITS

- **Jumper Bar Kit 3 Ckt. to 1 Ckt. RXBJ-A31** is used to convert single phase multiple three circuit units to a single supply circuit. Kit includes cover and screw for line side terminals.
- **Jumper Bar Kit 2 Ckt. to 1 Ckt. RXBJ-A21** is used to convert single phase multiple two circuit units to a single supply circuit. Kit includes cover and screw for line side terminals.

NOTE: No jumper bar kit is available to convert three phase multiple two circuit units to a single supply circuit.

6.3 AUXILIARY HORIZONTAL OVERFLOW PANS

Cabinet Size	Auxiliary Horizontal Overflow Pan Accessory Model Number
All 17.5" wide & (-)H2V2421M	RXBM-AC48
21' & 24.5" wide except (-)H2V2421M	RXBM-AC61

6.4 EXTERNAL FILTER BASES (See Figure 40)

Model Cabinet Size	Filter Size	Part Number	A	B
17	16 × 20 [406 × 508]	RXHF-17 Accommodate	15.70	17.50
21	20 × 20 [508 × 508]	RXHF-21 1" or 2"	19.20	21.00
24	25 × 20 [635 × 508]	RXHF-24 filter	22.70	25.50

FIGURE 40
EXTERNAL FILTER BASE: RXHF-

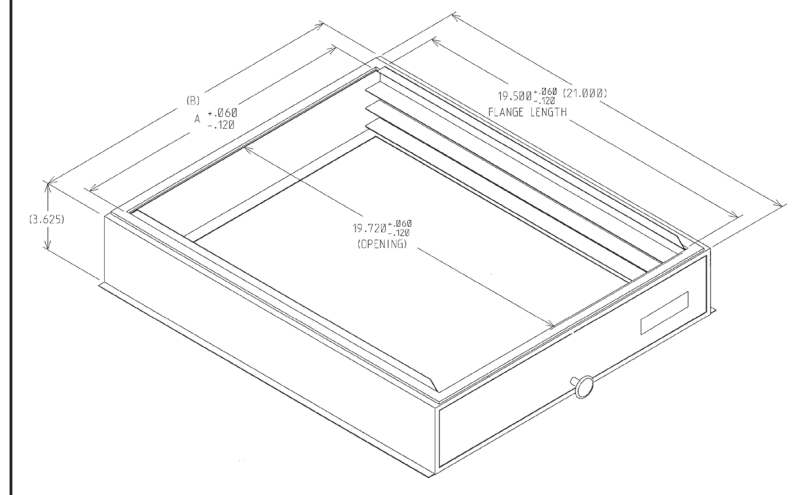

6.5 COMBUSTIBLE FLOOR BASES

For high heat downflow applications. (See Section 3.2.2.)

Model Cabinet Size	Combustible Floor Base Model Number
17	RXHB-17
21	RXHB-21
24	RXHB-24

6.6 HORIZONTAL ADAPTER KITS

This horizontal adapter kit is used to convert RCH replacement coils for horizontal applications if water management parts from original coil are not usable or are unavailable. See the following table to order proper horizontal adapter kit.

RCH Coil Model	Horizontal Adapter Kit Model Number (Single Qty.)	Horizontal Adapter Kit Model Number (10-pak Qty.)
2417S	RXHH-A02	RXHH-A02×10
2421M/3617S	RXHH-A03	RXHH-A03×10
3621M/4821S/4824S	RXHH-A04	RXHH-A04×10
6024S	RXHH-A05	RXHH-A05×10
3621H/4821M/6021S	RXHH-A06	RXHH-A06×10

7.0 MAINTENANCE

For continuing high performance, and to minimize possible equipment failure, it is essential that periodic maintenance be performed on this equipment. Consult your local dealer as to the proper frequency of maintenance and the availability of a maintenance contract.

IMPORTANT: Before performing any service or maintenance procedures, see the “Safety Information” (Section 1.0) at the front of this manual.

WARNING

Units with circuit breaker(s) meet requirements as a service disconnect switch, however, if access is required to the line side (covered) of the circuit breaker, this side of the breaker(s) will be energized with the breaker(s) de-energized. Contact with the line side can cause electrical shock resulting in personal injury or death.

7.1 AIR FILTER

Check the system filter every ninety days or as often as found to be necessary and if obstructed, clean or replace at once.

A qualified installer, service agency or HVAC professional should instruct the homeowner on how to access filters for regular maintenance.

IMPORTANT: Do not operate the system without a filter in place.

- New filters are available from a local distributor or home supply retailer.

7.2 INDOOR COIL, DRAIN PAN, DRAIN LINE

Inspect the indoor coil, drain pan, and drain line once each year for cleanliness and clean as necessary. Be sure to check the finned surface on the return side of the coil. It may be necessary to remove the air-filter and use a mirror and flashlight to view the return side of the coil.

NOTE: A proper filter is the best defense against a dirty coil. Regardless of the filter choice, proper air flow and velocity also play a crucial role in how effective a filter will be. Most filters will lose their effectiveness when face velocities exceed 300 - 400 feet per minute. Excessive air velocity can allow particles to pass right through the media. Additionally, loaded or restrictive filters may lose their shape in higher air velocity applications and allow unfiltered air to bypass the filter altogether around the sides.

IMPORTANT: Coil and Drainpan Cleaning Method

Clean the finned surface of the indoor coil by rinsing the coil from both sides with clean warm water and/or with a vacuum with a soft brush attachment to remove accumulated contaminants and lint. It is important not to allow the tool to damage or bend the fins. Many chemical cleaners will attack the aluminum tubes which can cause refrigerant leaks. Therefore, use only clean warm water for cleaning aluminum tube evaporator coils. Do not use caustic household drain cleaners or bleach in the condensate pan or near the indoor coil as they will damage the aluminum fins and tubes.

7.3 BLOWER MOTOR AND WHEEL

Inspect the blower motor and wheel for cleanliness. It should be several years before it would become necessary to clean the blower motor and wheel.

- If it becomes necessary to remove the blower assembly from the unit, see instructions on removal and replacement of motor, blower, and blower wheel in Sections 7.5-7.7 below.
- The blower motor and wheel may be cleaned by using a vacuum with a soft brush attachment. Remove grease with a mild solvent such as hot water and detergent. Be careful not to disturb the balance weights (clips) on the blower wheel blades. Do not drop or bend wheel as balance will be affected.

7.4 MOTOR LUBRICATION

The blower motor sleeve bearings are pre-lubricated by the motor manufacturer and do not have oiling ports. Motor should operate for an indefinite period of time without additional lubrication.

7.5 BLOWER ASSEMBLY REMOVAL & REPLACEMENT

Removing the blower assembly is not normally required for normal service and maintenance. Removal is necessary for replacement of defective parts such as motor, blower wheel. After extended use, removal of the blower assembly may become necessary for a thorough cleaning of the blower motor and wheel.

- Mark field power supply wiring (for replacement) attached to terminal block or circuit

- breaker(s) on blower assembly. Remove wiring from terminal block or circuit breaker(s).
- Mark low voltage control wiring (for replacement) where attached to unit control pig-tails on right side of blower housing. Remove wire nuts attaching field control wiring to unit control pigtails.
- Remove 4 screws holding blower assembly to front channel of cabinet and pull blower assembly from cabinet.
- To replace blower assembly, slide blower assembly into blower deck. Make sure blower assembly engages lances in deck properly. If assembly hangs up, check to make sure top and bottom are lined up in proper locations.
- Slide blower assembly to back of cabinet and make sure it is completely engaged.
- Replace 4 screws holding blower assembly to front channel of cabinet. Take care not to strip screws.
- Replace low voltage control wiring with wire nuts and make sure wiring is per the wiring diagram and all connections are tight and secure.
- Replace field power wiring to terminal block or circuit breaker(s) on control area of blower assembly. Make sure wires are connected per the wiring diagram. Tighten supply power wiring securely to terminals lugs.
- Make sure wiring is within cabinet and will not interfere with access door. Make sure there is proper separation between low voltage control wiring and field power wiring.
- Replace blower assembly control access panel before energizing equipment.

7.6 MOTOR REPLACEMENT

With the blower assembly removed, the indoor blower motor can be removed and replaced using the following procedure:

- Remove motor leads from the motor high and low voltage plugs. Note the lead locations for ease of re-assembly.
- Loosen the set screw holding the blower wheel onto the motor shaft. The shaft extends through the blower hub so that a wrench can be used on the extended shaft to break the shaft loose if necessary. Be careful not to damage the shaft. Use a wheel puller on the groove in the hub if necessary.
- Loosen the bolt holding the wire motor band around the motor shell and pull the motor from the motor mount. Note the motor position in the mount for re-assembly.
- To re-assemble, insert the motor shaft through the hub in the blower wheel and orient the motor to original position.
- For proper motor cooling, it is important that the motor be mounted the same as the original, as far into the blower as practical.
- The dimension from the face of the motor end plate (shaft end) to the first wire on the motor mount band around the shell should be:

DIMENSION	TONNAGE	CABINET SIZE
1 ³ / ₃₂ "	1 ¹ / ₂ & 2	17
1 ¹ / ₂ "	2 ¹ / ₂ & 3	17
2 ¹ / ₂ "	3, 3 ¹ / ₂ , 4, & 5	21
2 ⁷ / ₈ "	5	24

- With motor held to above position and motor lead plugs oriented to the original position (the wire connectors on the motor must point straight to the supply air end of the unit and away from the return air [filter] end of the unit). Securely tighten the bolt on the mount band to the motor shell.
- Turn the motor shaft so that the flat on the shaft is located under blower wheel set-screw, and the blower wheel is centered in the blower housing with the same distance on each side between the inlet venturi and the outside of the blower wheel.
- Re-assemble the motor wiring (high and low voltage plugs) into the motor.

IMPORTANT: DO NOT FORCE POWER PLUG INTO THE MOTOR CONNECTOR BACKWARDS. The A.C. power plug to the motor has locking tabs. It has been proven that by applying excessive force to the A.C. cable half of the connector it is possible to force the connector in backwards. It will not seat and “click” properly but will make connection. If A.C. power is applied with the connector reversed the motor will be immediately destroyed.

7.7 ECM CONTROL MODULE REPLACEMENT

Always take the following steps before replacing the control module on the end of the ECM indoor blower motor.

1. **HAVE THE CORRECT REPLACEMENT MODULE.** These controls are factory programmed for specific operating modes. Even though they look alike, different modules may have different CFM characteristics.

IMPORTANT: Using the wrong control module voids all product warranties and may produce unexpected results.

FIGURE 41
ECM MOTOR COMPONENTS

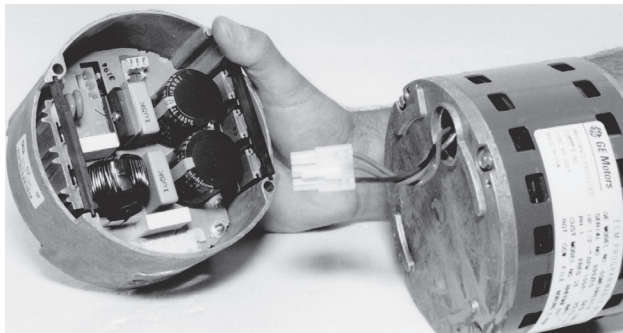
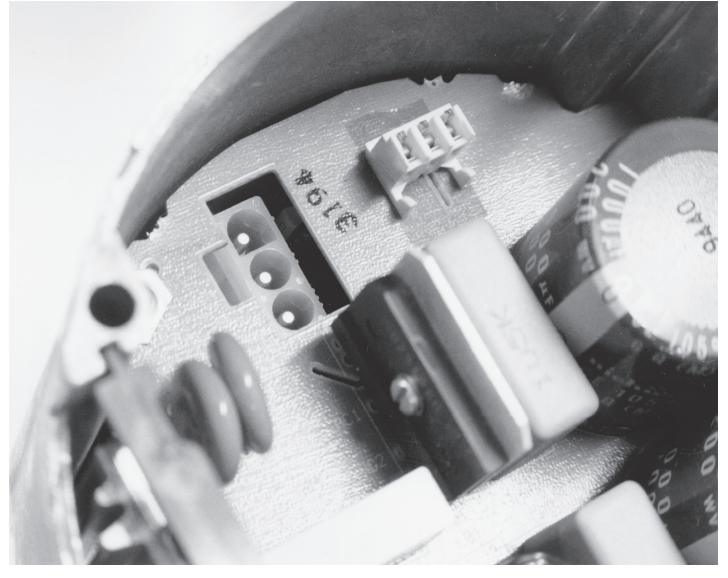

FIGURE 42
CONTROL MODULE CONNECTIONS



⚠ WARNING

Always have line voltage (208/240V) turned off to the furnace before attempting any replacement of the motor or control module. Failure to do so may result in serious equipment damage, personal injury or death.

2. Turn off power to the equipment. Wait at least 5 minutes after disconnecting AC power before opening the motor.
3. Remove the complete blower assembly from the air-handler. Unplug the two cable connectors to the motor. There are latches on each connector. **DO NOT PULL ON THE WIRES. TO REMOVE THE PLUG, SQUEEZE THE PIN LATCH.** The plugs remove easily when properly released.
4. Locate the two standard 1/4" hex head bolts on the flat end of the motor control module casting. Remove these bolts from the motor while holding the control module. **DO NOT REMOVE TWO SCREWS WITH TORX HEADS.**
5. The control module is still connected to the motor by a plug and cable. (See Figures 40 and 41) Carefully rotate the control so as to gain access to the plug on the cable end. Squeeze the release latch and gently pull the plug out of the control module. **DO NOT PULL ON THE WIRES. GRIP THE PLUG ONLY.**
6. The control module is now completely detached from the motor. To assure the motor hasn't failed rather than the control module, an ohmmeter can be used to test the windings of the motor.

Winding to Ground Test: Use an ohmmeter to measure the resistance from each motor lead terminal to the unpainted motor end plate. The motor lead terminals are located in the 3-pin plug that was just unplugged from the control module. This resistance must be greater than 100K ohms.

Winding to Winding Test: Set the ohmmeter to the lowest possible setting and measure the resistance between the 3 motor terminals in the 3-pin motor lead plug.

Terminal 1 to Terminal 2
Terminal 1 to Terminal 3
Terminal 2 to Terminal 3

For the purpose of the test, either end of the 3-pin plug can be designated as Terminal 1. Resistance values should be less than 20 ohms and each of the 3 values should be within 10% of each other.

IMPORTANT: If the motor passes both of the above tests and the shaft spins freely by hand, the motor is OK and replacement of the control module can continue. If the motor fails either of the above tests, do not replace the control module as the motor itself is likely the problem. Proceed to install a completely new motor/control module assembly.

7. Verify that the replacement control module is correct. Place the new module next to the motor and carefully insert the plug that was removed in step 5. **BE SURE THE PLUG LATCHES. IT SHOULD CLICK INTO PLACE.**
8. Install the new control module back on the motor.
9. Replace the two 1/4" hex head bolts. Tighten the bolts snugly. **DO NOT OVER TIGHTEN.**

IMPORTANT: Before replacing the blower motor assembly, check the installation

for any application fault that might have caused the motor or control module to fail. Water damage could show as corrosion on the inside or outside of the casting.

10. Install the blower assembly back into the air-handler.
11. Plug the **two cable connectors** into the motor. The connectors are keyed. Be sure the connectors are properly seated and latched. **OBSERVE THE PROPER ORIENTATION. DO NOT FORCE THE CONNECTORS.** They plug in very easily when properly oriented.
12. Final installation check. Be sure the motor is installed as follows.
 - a. The motor has been installed in the blower housing as originally provided from the manufacturer.
 - b. Do not allow the motor mount to cover the motor vent openings.
 - c. Do not attach the motor mount to the motor electronics compartment.
 - d. The motor connectors should be straight down.
 - e. Have appropriate drip loops formed in the harnesses.
13. Restore 230 volt power to the system. Verify that the motor functions properly.

7.8 BLOWER WHEEL REPLACEMENT

With the blower assembly removed and the motor assembly removed (see above instructions), remove the screws holding the blower wrap (cutoff) to the blower sides.

- With wrap (cutoff) screws removed, cut off end of blower wrap will spring up. Lifting wrap blower wheel is removed through the discharge opening in the blower housing.
- To replace, make sure wheel is oriented properly with hub to the opposite side from the motor. Lift blower wrap and insert blower wheel through discharge opening in the blower housing.
- Hold blower wrap down into position and replace screws holding blower wrap to blower sides.
- See motor replacement and blower assembly instructions for remaining assembly procedure.

7.9 REPLACEMENT PARTS

Any replacement part used to replace parts originally supplied on equipment must be the same as or an approved alternate to the original part supplied. The manufacturer will not be responsible for replacement parts not designed to physically fit or operate within the design parameters the original parts were selected for.

These parts include but are not limited to: Circuit breakers, heater controls, heater limit controls, heater elements, motor, motor capacitor, blower control, control transformer, blower wheel, indoor coil and sheet metal parts.

When ordering replacement parts, it is necessary to order by part number and include

CAUTION

Reversing the 5-pin connector on the ECM motor causes immediate failure of the control module.

with the order the complete model number and serial number from the unit data plate. (See Parts List for unit component part numbers).

8.0 DIAGNOSTICS

Problem	Possible Cause (Suggested Fix)
Blower motor will not operate	<ul style="list-style-type: none"> Failed motor (replace) Failed motor control module (replace module) Blown 3A fuse on blower control (check for control circuit short, replace fuse) Loose wiring connection or broken wire (check connections & wiring) Failed transformer (replace) Failed ECM motor interface control board (replace) Disconnect breaker is turned off or has tripped due to overcurrent or shorted circuit (check for shorts, reset breaker)
Excessive vibration	<ul style="list-style-type: none"> Blower wheel out of balance (replace or clean blower wheel)
Water overflowing drainpan	<ul style="list-style-type: none"> Plugged drain (clear drain) Unit not level (level unit)
Electric heater not heating properly or not heating at all, but blower motor is operating	<ul style="list-style-type: none"> Over temperature limit has tripped (check for low air-flow) Over temperature limit has failed (replace) Sequencer or contactor has failed (replace) One or more heating elements have burned out (replace)
Coil is frozen up	<ul style="list-style-type: none"> System low on refrigerant charge (check for leaks & adjust charge) Dirty return air filter (replace filter) Inadequate air-flow due to incorrect blower motor speed selected (select higher speed) or excessively restrictive duct system (correct duct system)
Excessive air-flow	<ul style="list-style-type: none"> Incorrect blower motor speed selected (select lower speed)
Water blow-off from coil	<ul style="list-style-type: none"> Excessive air-flow (select lower blower motor speed) Contaminants on coil fins (clean coil) Damaged coil fins (comb out fins or replace coil)
TXV not controlling properly	<ul style="list-style-type: none"> TXV bulb not positioned correctly or clamp not tight (Check position of TXV sensing bulb and tightness of clamp) Failed TXV (replace) Plugged TXV inlet screen (clean or replace screen or replace TXV)

9.0 WIRING DIAGRAM (-)H1V & (-)H2V

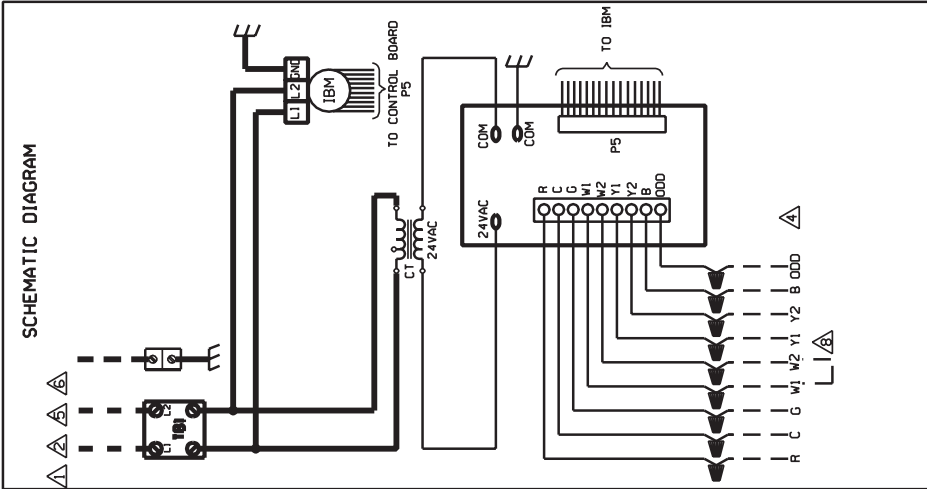

WIRE COLOR CODE
 BK.....BLACK G.....GREEN PR.....PURPLE
 BR.....BROWN GY.....GRAY R.....RED
 BL.....BLUE O.....ORANGE W.....WHITE
 Y.....YELLOW

ELECTRICAL WIRING DIAGRAM
ELECTRIC AIR HANDLER
NON-COMMUNICATING
ECM MOTOR

DR. BY MGR DWG. NO. 90-101898-01 REV. 07

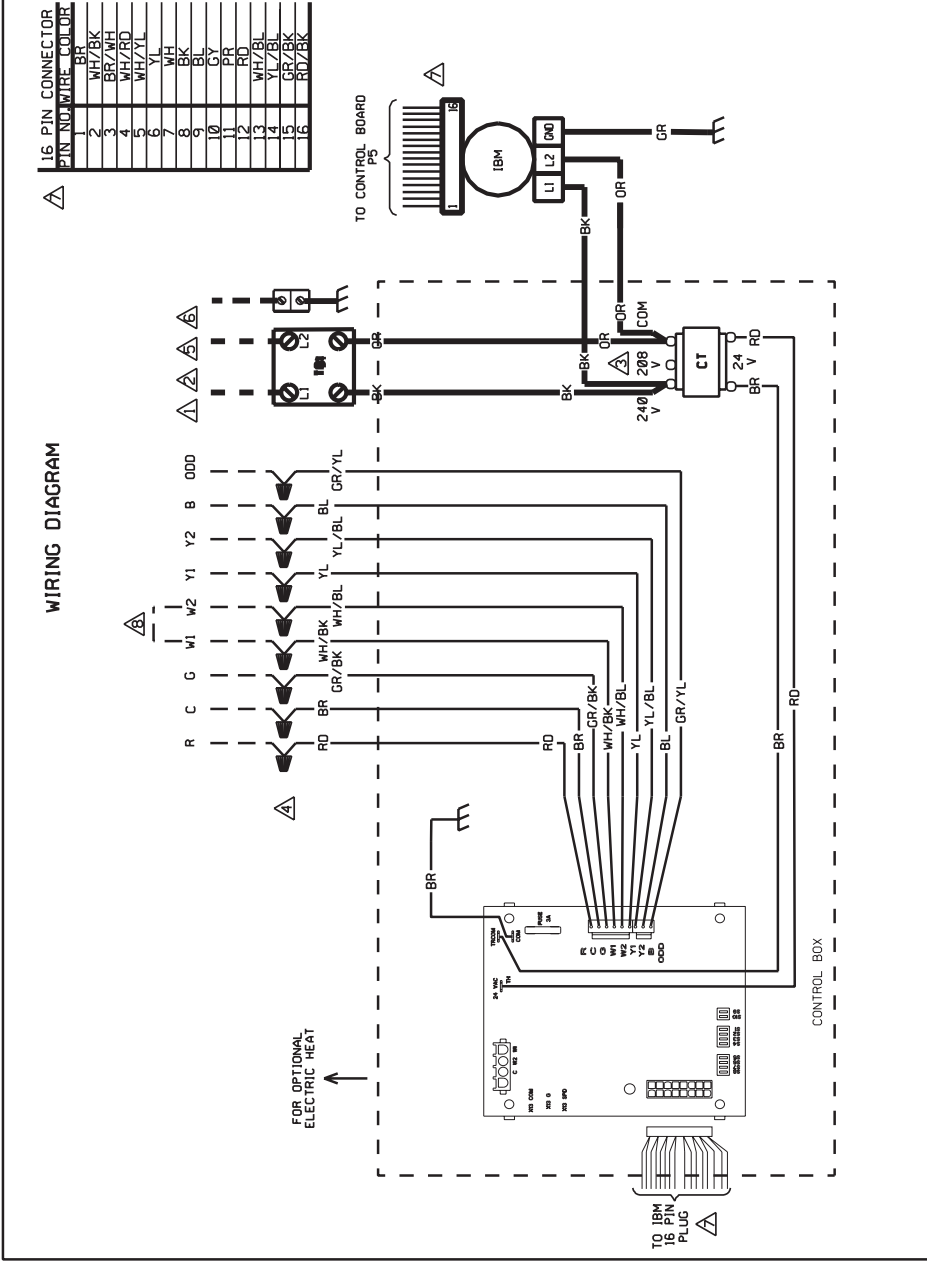

16 PIN CONNECTOR

PIN	WIRE COLOR
1	BR
2	WH/BK
3	BR/WH
4	WH/RD
5	WH/YL
6	YL
7	WH
8	BK
9	BL
10	GY
11	GR
12	WH/BL
13	YL/BL
14	GR/BK
15	RD/BK
16	

LINE VOLTAGE
LOW VOLTAGE
REPLACEMENT WIRE
WARNING

CT CONTROL TRANSFORMER
GND GROUND
IBM INDOOR BLOWER MOTOR
TB TERMINAL BLOCK (HI VOLT)
▲ WIRE NUT

▲ CONNECT SUPPLY WIRING FOR VOLTAGE, PHASE AND HERTZ SHOWN ON RATING PLATE.
 ▲ SUPPLY WIRE MUST BE RATED AT 75° C MIN. SEE INSTRUCTIONS FOR SIZE.
 ▲ CT FACTORY WIRE FOR 240V VOLTS. MOVE WIRES FROM 240V TO 208V FOR 208V OPERATION.
 ▲ CONTROL WIRING TO THERMOSTAT.
 ▲ FOR USE WITH COPPER CONDUCTORS ONLY.
 ▲ WHEN HEATER KIT IS INSTALLED, POWER IS APPLIED TO HEATER KIT DISCONNECT OR TERMINAL BLOCK. WIRES ARE PROVIDED IN HEATER KIT TO CONNECT TO TBI. WITHOUT ELECTRIC HEAT, FIELD POWER WIRES ARE ATTACHED TO TBI. SEE CHART FOR WIRE COLORS.
 ▲ WHEN USING 13KW AND HIGHER IT IS RECOMMENDED TO JUMP W1 AND W2 TOGETHER FOR MAXIMUM TEMPERATURE RISE.

